

Bryce 4

User Guide
for Macintosh® and Windows®

Trademarks

Bryce is a trademark of MetaCreations Corporation. QuickDraw and QuickTime are trademarks, and Apple, Macintosh and Power Macintosh are registered trademarks of Apple Computers, Inc. Windows is a registered trademark and Video for Windows is a trademark of Microsoft Corporation. All other product and brand names mentioned in this user guide are trademarks or registered trademarks of their respective holders.

Copyright

This manual, as well as the software described in it is furnished under license and may only be used or copied in accordance with the terms of such license. Program copyright ©1990-1999 MetaCreations Corporation, including the look and feel of the product. Bryce User Guide copyright ©1999 MetaCreations Corporation. No part of this guide may be reproduced in any form or by any means without the prior written permission of MetaCreations Corporation.

Notice

Before using this software or reading this user guide, make sure you have read, understood and agreed to the license contained in the back of the Bryce 4 User Guide.

Credits

Bryce™ was originally created by Phil Clevenger, Kai Krause, Sree Kotay and Eric Wenger.

Bryce 4™ was created by Ken Musgrave, Sam Coroniti, Ian Gilman, Paul Catrone, Michael Herf, and Maria Giannakouros.

UI Design by Robert Bailey and Jackson Ting.

Product Management by John Feld.

Special thanks to Susan Kitchens for technical inspiration on textures and the Deep Texture Editor.

Box Design by Magdelana Bassett and Darin Sullivan.

Quality Assurance testing by Meredith Keiser, Fernando Corrado, Kevin Prendergast, and Stephen Watts.

The Bryce User Guide was written by Erick Vera; updated by Lynn Flink and Donna Ford; edited by Valarie Sanford; project management by Erick Vera; art directed by Garvin Soutar; illustrated by Garvin Soutar and Heather Chargin; production by Erick Vera; prepress production by Rich O'Rielly and Erick Vera; review and validation by Brian Wagner and Ales Holecek; tutorials written and illustrated by Peter Sharpe (<http://www.petersharpe.com>), and Susan Kitchens (<http://www.auntialias.com>).

Chapter openers by Garvin Soutar. Section dividers illustrated by Bill Munns.

Cover artwork by Robert Bailey and Jackson Ting.





1

Welcome to Bryce 4

Welcome to Bryce™4, the leading 3D program for desktop artists and animators, web designers, and multimedia producers. Bryce is ideal for creating 3D graphics for magazines, ads, or virtually any illustration that would benefit from the powerful 3D impact of realistic perspective and shading.

Bryce's easy animation features let you create great animations for video and multimedia. Bryce's key-event and timeline-based animation lets you create incredibly realistic, fully-animated, 3D worlds where rivers rush through gorges, the sun sets over the ocean, or mist evaporates to reveal flocks of birds soaring between mountain peaks.

Bryce can also be an invaluable tool for interactive multimedia.

Your Bryce package includes:

- The Bryce CD-ROM
- The Bryce User Guide
- The Bryce Quick Reference Card
- Your Bryce serial number
- A Software Registration Card

If you are missing any of these items, please contact your Bryce dealer, distributor, or Meta-Creations Customer Service at (831) 430-4063.

What's New in Bryce

The new Bryce 4 has new tools, features, and improvements from Bryce 3D. For those of you who are upgrading, the overview in the following paragraphs provides a head start on locating, learning about, and taking advantage of new features in Bryce, that include:

New Sky Lab

The Sky Lab provides new and improved tools for creating stunning skies. It provides one-stop access to Cloud, Atmosphere, and Sun and Moon controls. Refer to “Creating Skies” on page 123 for more information.

New Import/Export

Many additional image formats and object types are supported for import and export including US Geological Survey maps, (.DEM) files, and USGS SDTS files. Refer to “Using Bryce with Other Applications” on page 417 for more information.

Terrain Enhancements

Bryce 4 provides over 20 new fractal terrain creation models.

In addition, you can perform textured terrain exports through the new real-time, multi-resolution, Export Lab which converts Bryce terrains into mesh objects for export in all popular 3D file formats. Terrain mesh density is fully user adjustable and you can have instant visual feedback with real-time textured preview. Refer to “Terrains” on page 157 for more information.

Using Bryce on the Web

Use Bryce to export both still or motion images to the web with embedded object links. You can also communicate with other Bryce users via BryceTalk, or go directly to Bryce-related web links from within Bryce. Refer to “Using Bryce on the Web” on page 423 for more information.

Interactive Movie Previewing

Now, you can immediately see your Bryce animation in a preview window without having to render it, then play it using an external viewer. You can quickly generate thumbnail previews of your animations, preview animations directly within Bryce, or navigate through your animation using a storyboard style interface. Refer to “Animating” on page 353 for more information.

Enhanced Rendering

You can enhance render quality using gamma correction and 48 bit dithering. Lights have a new falloff mode for more control over how far light travels.

Bryce 4 provides new and improved texture mapping modes, along with a new material shading mode to control self-shadowing of objects. Refer to “Rendering” on page 403 for more information.

Enhanced Screen Resolution

Since monitors do not always display a full range of colors, Bryce has compensated by adding gamma correction so that colors are truer, terrains more natural, and earth tones more real.

Bryce also now has an automatic process called 48 bit dithering that allows for a better display of gradients. Instead of distinct color bands, you now see a smoother transition from one color to the next.

Light Editor Enhancements

Bryce 4 now provides more control over the way light falls. The Light Editor contains options for a falloff method and distance. In addition to gradual dimming, you can now choose to stop light abruptly. Refer to “The Camera and Lights” on page 325 for more information.

New Material Lab features

Many new options in the Materials Lab let you apply pictures in new ways that include tiling and mirroring. Bryce also allows you to export textured terrains as Metastream files. Refer to “Materials” on page 189 for more information.

Picture Editor Enhancements

You can launch Photoshop plug-ins to enhance or edit your 2D image map textures. In addition you can import more image formats than ever. Refer to “Working with Pictures” on page 108 for more information.

Preset Enhancements

You can create your own preset categories, and easily organize your presets. Refer to *zot* for more information.

About Your User Guide

This user guide provides all the information you need to get the most out of Bryce. It will help you learn the application as well as serve as a reference as you attempt more sophisticated procedures and effects.

We assume you are already familiar with basic Macintosh and Windows concepts such as menus, dialogs, and mouse operations. If you need more information on these subjects, or on the Macintosh Finder or the Windows Desktop, refer to the Macintosh User’s Manual or the Microsoft Windows User’s Guide, respectively.

The best way to learn Bryce is to read “Bryce Basics” on page 15 and then complete the “Tutorial” on page 47. The tutorial leads you through the process of creating illustrations and animations in Bryce and also explains some of the important concepts you’ll need to know in order to model and animate in 3D.

After you complete the tutorial, you are ready to open a new file and start building your own scene.

Computer graphics and three-dimensional modeling use special terms that are usually explained where they are introduced. In addition, “Glossary” on page 433 provides concise definitions of a number of terms.

Conventions

The Bryce User Guide is for both Macintosh and Windows. By convention, Macintosh commands precede Windows commands in the text. For example, **Command/Ctrl+I**, is equivalent to the Macintosh **Command-I** and the Windows **Ctrl+I**. For simplicity, the term **folder** refers to directories as well as folders. Screenshots may alternate between the Macintosh and Windows versions. The Bryce interface for both platforms is identical, unless otherwise specified.

There are also several conventions used to identify paths to certain tools and controls. The convention to a menu follows the rule of the **menu name > menu item**. The convention to a palette follows the rule of the **palette name: subpalette name** or **palette item**. The convention to a palette menu follows the rule of **palette name: palette menu > menu item**.

Modifier Keys

When a modifier key differs between the Macintosh and Windows platform, the Macintosh modifier is listed first followed by a slash and the Windows modifier key. **Option/Alt** means Macintosh users press the **Option** key and Windows users press **Alt**.

Technical Support

Technical support is free* to registered users of Bryce 4. There are two easy ways to contact technical support for questions about installation, configuration, or functionality. These options are: web and phone support.

*MetaCreations does not currently charge for technical support. The only expense to you is the telephone call charge. MetaCreations

reserves the right to change this support policy at any time.

You will find the answers to most of your questions within the pages of this User Guide. If you need further assistance, you may contact MetaCreations Technical Support in one of the following ways:

Web Support

Many of the answers to your questions are available 24 hours a day on our website:

<http://www.metacreations.com/support>.

In addition to frequently asked questions (FAQs), the website provides troubleshooting techniques, late breaking product news, and other resources to help you get the most out of Bryce.

Phone Support

Phone support hours are Monday–Friday, 8:00 AM–5:00 PM, Pacific Standard Time, excluding holidays.

Call (831) 430-4063. When you call, please have your serial number available and be at the computer for which you need assistance.

For international support, please contact your local distributor. To locate the distributor nearest to you, check the web site at:

<http://www.metacreations.com/support/intl>

Creative Support

You can also refer to forums and mail-lists on the MetaCreations website for questions about creative techniques.



2

Bryce Overview

What is Bryce?

Bryce is a stand-alone application that allows you to create and animate virtual environments.

With Bryce you can create any type of environment you can envision, from the ivory beaches of Tahiti to the silvery rings of Saturn. Bryce's user interface contains all the tools you'll need to create your environments.

For example, Bryce includes controls for managing infinite skies that let you set everything from time of day to the color and frequency of clouds. Using the sky controls you can also set light direction, sun/moonlight, atmospheric depth haze (with intensity and color), height fog (with height, intensity and color), and multiple sky color components.

You can also use Bryce controls to create a wide variety of objects you can use to populate your environment. You can use the Terrain editor to create an infinite number of custom terrains, which you, in turn, use to create landscapes.

The realism of a Bryce environment is largely dependent on the Materials applied to the

objects in the scene. Materials are complex combinations of textures and values. The Materials Lab lets you combine textures and channel values that simulate any material found in the real world (and a few that aren't!).

When you have set up your environment just the way you want it, you can add a fourth dimension—time. You can use Bryce's animation tools to set up landscapes that move and materials that change over time.

Application Overview

The Bryce Window

Bryce's default environment consists of the Working window, the Control palette, and the Tool palettes.

By default, the Bryce environment replaces your screen whenever you launch the application. However, your operating system's standard menus and windows are still available from within Bryce.

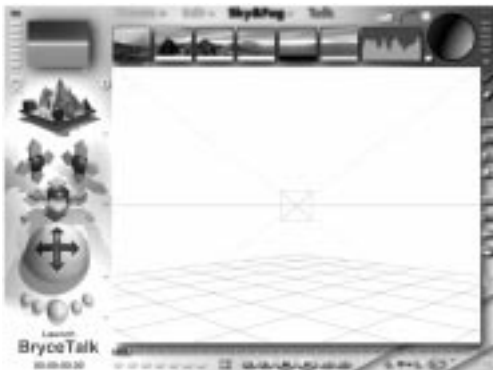

When you launch the application, the Bryce window replaces your desktop.

The Working Window

The Working window displays all the objects in your Bryce scene. It's the work area where you'll arrange the objects and lights to create your environment.

The view of your scene shown in the Working window is taken from a "camera" that you can move around for different views of your scene.

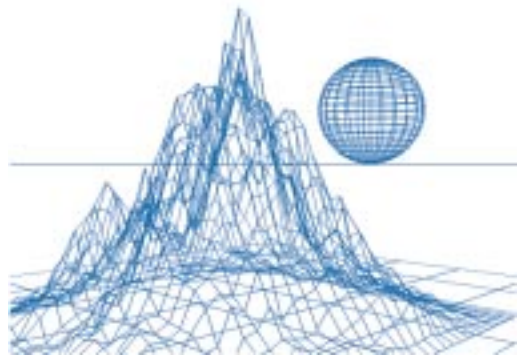

The Working window displays all the objects that make up your scene.

The Working window also has several display modes that let you view am as a wireframe, rendered object, or combination of both.

Refer to "Display Modes" on page 17 for more information.

Nano-Preview

The Nano-Preview feature displays a rendered preview of your scene. As you update your scene, Nano-Preview shows your changes. You can immediately see how your adjustments to object position or other properties affect the final look of the scene.

Several display options let you control how

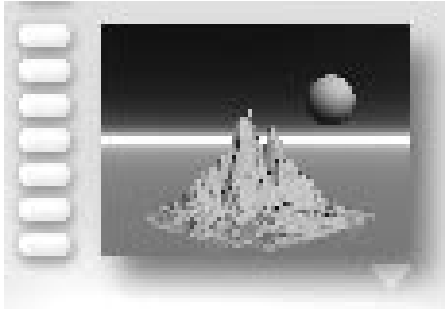

The Nano-Preview window shows a small rendered version of your scene. As you change the scene, the display updates to show your changes.

your scene appears in the Nano-Preview and can be very helpful when you're working on a complex scene.

You can also use the Nano-Preview's preset viewing positions to see your scene from different angles that help you quickly see the effects of your changes in 3D space.

The Memory Dots along the side of the Nano-Preview let you store your favorite camera positions.

Refer to "Using the Nano-Preview" on page 24 for more on working with the Nano-Preview.

View Control

View Control lets you adjust the view of your scene without moving the camera..



The View Control lets you control how you see your scene.

Using this control you can see your scene from the top, bottom, left, right, front or back. You can also set your scene to continuously rotate so you can see it from any angle. Refer to "View Control" on page 9 for more on using the View Control.

Camera Controls

Camera Controls change the position of the camera specifically along the X, Y, and Z axes. The Camera Trackball lets you move the camera in any direction, and along any axis.

Refer to “Camera Controls” on page 9 for more on moving the camera.



Use the Camera controls to adjust the position of the camera.

Render Controls

Render Controls let you render your scene to see all the materials and lighting effects you added.

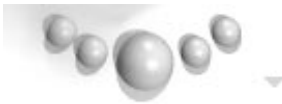

The Render controls let you render your scene as a 2D image.

The center button starts the rendering process and the other buttons control rendering options. Refer to “Rendering a Scene” on page 410 for more on rendering.

Text Display Area

The area just below the Render Controls is reserved for momentary display of text information. This area identifies the names of interface elements as you pass your cursor over them as well as displaying information about total number of polygons in a scene and current control settings.



The Text Display Area displays the name of items in the user interface as you pass your cursor over them. This area also displays information about tool settings.

The Tool Palettes

Bryce uses a series of palettes to manage tools and controls—the Create palette, Edit palette, Sky & Fog palette, Advanced Display palette, Selection palette, and Animation controls. These palettes let you create objects, edit objects, create skies and fog, control the display of your scene, select objects, and animate objects.

Beside the title of each of the three palettes, along the top of the interface, is a small triangle which opens the different Preset Libraries available in Bryce.

The Create Palette

The Create palette contains tools for creating infinite planes, terrains, stones, primitive shapes, derivative primitives, 2D picture objects, and lights.

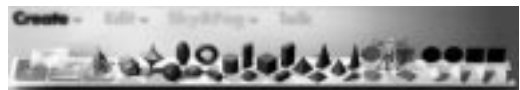

The Create palette contains tools for creating all the types of objects you can use in a Bryce scene.

The Triangle icon for this palette opens the Preset Objects Library. Refer to “The Create Palette” on page 100 for more on the Create palette.

The Edit Palette

The Edit palette contains tools for editing object materials, resizing, rotating, repositioning, aligning, and randomizing objects. The Edit Terrain Object tool accesses the Terrain Editor, which lets you design and adjust terrain objects.



The Edit palette contains tools for transforming objects and accessing the Editors.

The Triangle icon for this palette opens the Preset Materials Library. Refer to “Transforming Objects” on page 285 for more on the Edit palette.

The Sky & Fog Palette

The controls available on this palette let you add shadows, fog, and haze, and also set the altitude, frequency, and amplitude of clouds. The palette lets you control the color of clouds in your sky and the position of the sun and moon.



The Sky & Fog palette contains tools for creating the environment of your Bryce scene.

The memory dots along the side of the palette let you store your favorite sky and fog settings.

The Triangle icon for this palette opens the Preset Sky & Fog Library. Refer to “[The Sky & Fog Palette](#)” on page 124 for more on the Sky & Fog palette.

Advanced Display Palette

The Advanced Display is not visible in the main interface. It only appears when you pass the mouse over the right side of the Working window. After you’re finished working with the palette it gradually fades away so that it does not clutter the screen.

The Advanced Display palette contains tools for controlling the display of the interface and enabling/disabling the Nano-Editor and Plop Render features. You can also control the resolution of the Wireframes preview, zoom in and out, enable or disable wireframe shadows, access different shaders, and set underground and depth cues. Refer to “[Viewing Your Scene](#)” on page 25 for more on using the Advanced Display palette tools.



The Advanced Display palette contains tools for changing the Working window display.

The Animation Controls

The Animation controls lets you set up key frames and edit the timeline of your animation.



The Animation controls display the timeline of your animation.

It also contains controls for previewing your animation, adding and deleting key frames and accessing the Advanced Motion Lab. Refer to “Setting Up an Animation” on page 357 for more on using the Animation controls.

Selection Palette

The Selection palette contains tools for selecting specific types of objects in your scene. You do not see this palette in the default Working window. To view it, you must use the Time/ Selection Palette toggle at the far bottom right of your Working window to swap the Animation controls for the Selection palette.

Using the palette tools, you can select objects by type, by group or family. Refer to “Selecting Objects” on page 30 for more on selecting objects.



The Selection palette contains tools that let you set objects by type or family.

The VCR controls available in this palette let you cycle through the selections and enables Solo mode. Refer to “The VCR Controls” on page 32 for more on using the VCR controls.



Use the VCR Controls to cycle through all the objects in your scene and activate Solo mode.

The Editors

Bryce has several editors that let you do everything from creating terrains to editing the speed of animation. Each editor is like a separate room in Bryce. When active, the editor takes over the interface, completely replacing the Working window.

The Terrain Editor

The Terrain Editor is where you’ll create all the terrain objects in your scene. The editor contains tools for painting and refining terrain objects.



The Terrain Editor lets you create any type of landscape using the preset tools and paint brush.

The Terrain Editor also has a real-time preview so you can see the effects of your changes instantly.

Three tabs in the Terrain Editor let you switch between the various terrain creation tools:

- Elevation provides access to the terrain generation and editing tools.
- Filtering lets you adjust the filter curve for a terrain. By adjusting this curve you can make subtle changes to the topography of your terrain.
- Picture lets you use 2D pictures to create terrains.

Refer to “[The Terrain Editor](#)” on page 158 for more on the Terrain Editor.

The Materials Lab

The Materials Lab is where you'll create the materials to apply to your objects. By combining up to four texture components on the materials grid, you can create incredibly complex surfaces that can bring your scene to life.



The Materials Lab lets you create different types of materials by combining texture components on the materials grid.

There are two types of materials you can create: Surface materials, which define the surface properties of an object, and Volume materials, which define the properties of an object's volume as well as its surface. Refer to "The Materials Lab" on page 227 for more on the Materials Lab.

When you're creating a Volume material, the settings available in the Materials Lab change. The settings that appear let you set up the volumetric properties of the material. Refer to "Understanding Volume Material Channels" on page 193 for more on Volume materials.



When you're creating volume materials the settings in the Materials Lab change. Some of the surface material settings are replaced by volume effects settings.

The Advanced Motion Lab

The Advanced Motion Lab lets you fine-tune your animations. After you've created your key frames, using the Animation controls, you can use the tools available in this lab to control the speed at which objects move along a motion path, adjust the position of key frames, and preview your changes.



The Advanced Motion Lab lets you refine the action in your animations. Use the Velocity Curve editor to create different velocity effects and the Hierarchy area to control when object transformations occur.

There are three areas within the Advanced Motion Lab that let you edit specific aspects of your animations: the Time Mapping Curve editor, the Hierarchy List and the Sequencer.

The Time Mapping Curve editor lets you create a time mapping filter which alters how the time in your animation is mapped to actual time.

By adjusting the shape of a time mapping curve you can create different velocity effects. Refer to “Time Mapping Curves” on page 371 for more on velocity curves.

The Hierarchy List area lets you see how objects are linked and grouped within your scene. Although you can’t change the hierarchy of your scene in this area, it can be a valuable visualization tool.

The Sequencer lets you see where key events were recorded for all of an object’s properties. Using this area you can control exactly when object transformations occur. Refer to “Properties in the Sequencer” on page 355 for more on the Sequencer.

The Bryce Preset Libraries

Bryce has several libraries of presets that can make creating scenes easier. There are three main preset Libraries available in Bryce: the Preset Objects Library, the Materials Presets Library, and the Sky & Fog Preset Library. You can use the objects library to add pre-made objects to your scene. Refer to “Using the Pre-

sets Object Library” on page 119 for more on the Preset Objects Library.



The Preset Object Library contains a variety of 3D objects you can use in your scene.

The Materials library lets you add a wide variety of materials to your objects. Refer to “Using the Preset Materials Library” on page 232 for more on the Preset Materials Library.

The Sky & Fog Preset library contains pre-made skies that you can add to your scene to quickly create an environment. Refer to “Using the Preset Skies Library” on page 155 for more on the Preset Sky & Fog Library.

The Menu Bar

The Bryce menu bar contains three menus: the File menu, the Edit menu, and the Objects menu. These menus provide access to several Bryce functions and editors.

The display of the menu bar depends on the state of the application. When the application interface snaps to the edges of your Working window, the menu bar is hidden until you pass the pointer over the menu bar area.

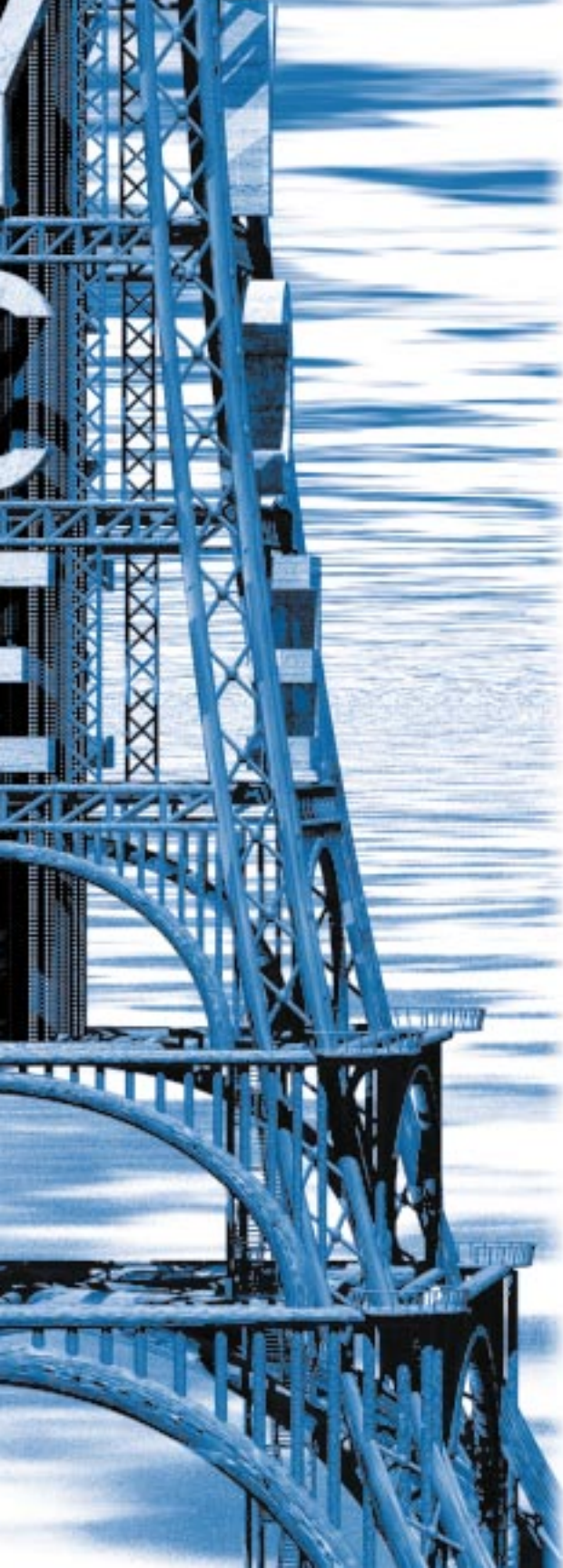

3

Bryce Basics

Overview

This section describes how to perform most of the basic functions in Bryce and how to set up the application.

Setting Application Preferences

By setting application Preferences, you can customize Bryce to suit the way you work. You do not have to restart Bryce to make these changes take effect.

Application Preferences are set in the Preferences dialog.

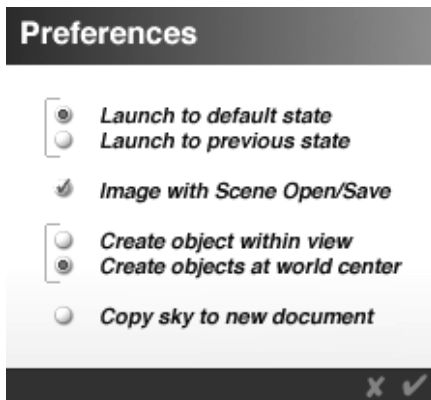

The Preferences dialog lets you set the opening state of the application and customize it.

To set the application's launch state:

- 1 Choose **Edit menu> Preferences**. The Preferences dialog appears.
- 2 Enable either **Launch to Previous State** or **Launch to Default State**.
Launch to Previous State launches Bryce using the settings from your last session.
Launch to Default State launches Bryce using the default settings.

To save Images used in a scene with a file:

- 1 Choose **Edit menu> Preferences**. The Preferences dialog appears.
- 2 Enable **Image with Scene Open/Save**.
With this option enabled, Bryce will automatically open or save a PICT or BMP file (PICT/BMP files are automatically appended with the extension), along with your scene file, every time you open or save. In most cases, this option should always be selected.

To control new object placement:

- 1 Choose **Edit menu> Preferences**. The Preferences dialog appears.
- 2 Enable either **Create Objects Within View** or **Create Objects at World Center**.
Create Objects Within View places newly created objects within the camera view, rather than at world center.
Create Objects at World Center places newly created objects at world center, regardless of whether they will be visible in your current camera view.

Setting Up the Bryce Window

When you first launch Bryce, the interface snaps to the edges of your Working window. The menu bar is hidden until you pass your cursor over it and other applications are hidden behind Bryce. This setup lets you work with an uncluttered desktop.

To maximize the Bryce window:

- 1 Pass the cursor over the right side of the Working window. The Advanced Display palette appears.
- 2 Click the Interface Max/Min tool.



Use the Interface Max/Min tool to increase or decrease the screen coverage of the Bryce window.

- 3 Click the tool again to switch to a standard window.

Setting Up the Working Window

Before you start working in Bryce, you may want to set up how objects are displayed in the Working window. These display modes can help you when you're arranging objects and can also speed up your redraw time.

Display Modes

The Display Mode tool, at the bottom-right corner of your Working window, toggles through the three possible display modes.

To switch between display modes:

- 1 Click on the Display Mode tool in the corner of the Working window.



This button is only visible when you pass your pointer over it.

- 2 Click the button until you're in the desired mode.

There are three modes available:

- Wireframe Display shows all objects as wireframes.

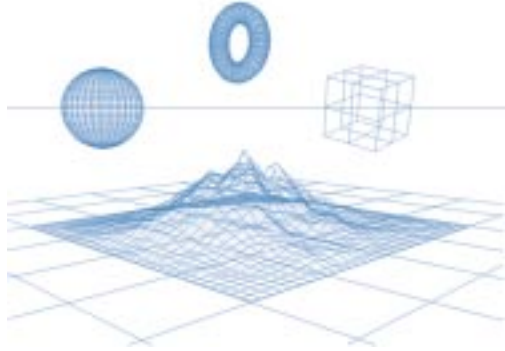

In Wireframe Display all objects are shown as wireframes.

- Bitmap Display shows a rendered scene. The display automatically switches to this mode whenever you click the Render button.

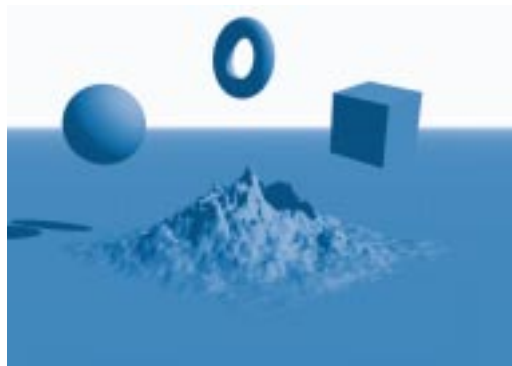

In Bitmap Display all objects are displayed as rendered objects.

- Wireframe/Bitmap Display lets you edit wireframes while simultaneously viewing your rendered image behind them.

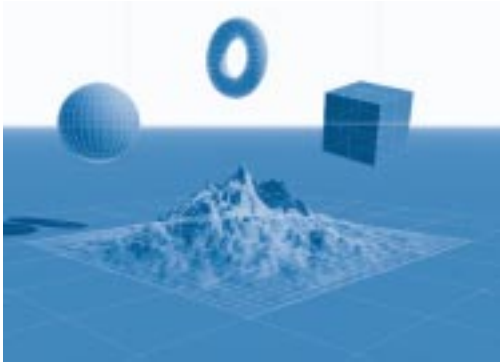

In Wireframe/Bitmap display, all objects are displayed as wireframes, but with the rendered image in the background.

This mode is most useful when you have a partially-rendered image and want to improve the results. If you switch to this mode, you can move your wireframe objects relative to the rendered image behind them in order to accurately judge the results of your change.

To toggle between modes:

- Press the Esc key.

The Esc key will toggle between the last Wireframe mode you selected (Wireframe or Wireframe/Bitmap) and Bitmap mode.

Flat Shaded Preview Mode

This preview mode is only available if your system contains hardware that supports OpenGL.

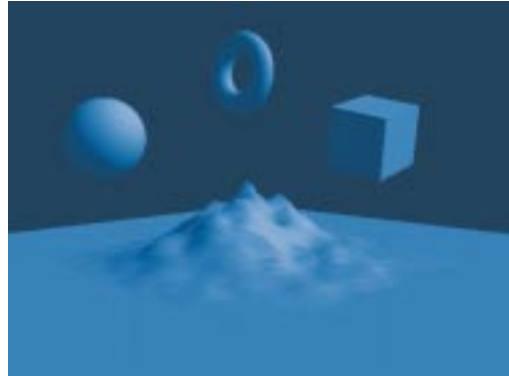

In Flat Shaded Preview display, all objects are displayed as flat shaded solids.

When this mode is active your objects appear as flat shaded solids, without materials, instead of wireframes, and you can see the effects of light sources on object surfaces.

To display objects in Flat Shaded Preview:

- Hold down the mouse button over the Display Mode button and choose OpenGL from the menu.

Wireframe attributes

When you're in Wireframe mode, there are several options you can set to make the display more helpful. Disabling some of these options may speed up drawing time.

To set Wireframe attributes:

- 1 Make sure you're in Wireframe mode. Click the Display Mode tool until the display switches to Wireframe.

- 2 Drag the Depth Cue control up or down. Drag up to increase the intensity of the depth cueing effect and drag down to decrease it.



When depth cueing is active, the wireframe appears lighter the farther it is from the camera.

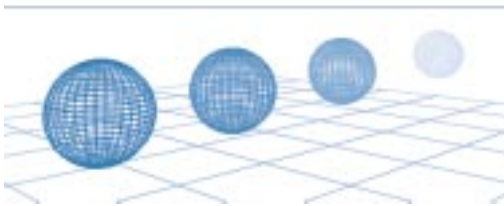

When depth cueing is active, objects appear lighter the farther they are from the camera.

If you hold down the Control key/Ctrl+Alt keys and click on the Depth Cue icon, Bryce will turn both anti-aliased wireframes and depth cueing on or off simultaneously.

- 3 Click the Wireframe Shadows button to turn shadows on or off.



Shadows are designed to help you determine object placement in your scene. For this reason shadows appear even when

there is no ground plane or when the object is below the ground plane.



You can use wireframe shadows to help you determine the placement of objects in the scene.

This feature may slow down your system when working with a complex scene on slower machines.

- 4 Click the Underground On/Off button to hide or show underground lines.



When underground lines are hidden, any portion of a terrain or object that is positioned below ground level will not be visible in your wireframe scene. This is useful for easy visualization and composition. However, you might overlook an object that is hidden underground.

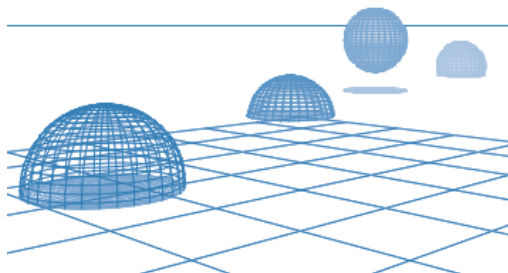

When underground is enabled, objects that are positioned below the ground plane are not visible in the scene.

- 5 Click the Resolution tool and choose Static, Selected, or Motion. Then choose a resolution for the wireframe mode.



Static is the resolution of the wireframe when the object is not moving and not selected. The resolution is affected by what is entered.

Selected is the resolution of the wireframe when the object is selected.

Motion is the resolution of the wireframe when the object is being moved.

Window Backgrounds

The background texture of the working window can add a great deal to the overall look of the interface. It makes it easier to see wireframes and selected objects.

To select a background texture:

- Click the Background Paper button and choose a background from the menu.



Adding a background texture may slow down some machines. If you need more speed for any reason, select No Texture, and you will get a simple, clean background with no texture.

To select a background color:

- 1 Click the Background Paper button and choose Select Color from the menu.
- 2 Use the color picker to select a color.

Using the Bryce Interface

The Bryce interface can be completely customized. If you want to, you can tear apart the interface and reposition any palette, or you can choose to hide the entire interface and leave only the working window visible.

To move a palette:

- Hold down the Spacebar and drag the desired palette to a new location.

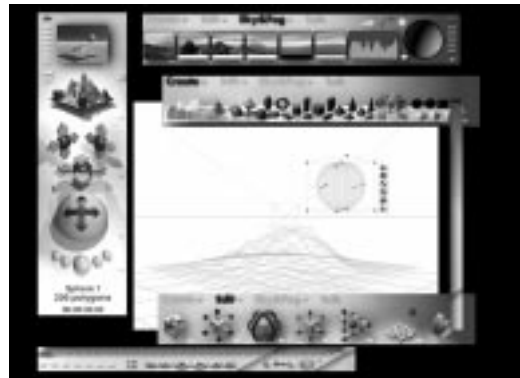

When you break the interface apart, you can see all the palettes at the same time. You can move these palettes anywhere in the Bryce window.

To reset a palette to its original position:

- Hold down the Option/Alt key and the Spacebar, then either click on a palette or choose **Edit menu > Reset Palettes** to reset all palettes to their default positions.

To hide the Bryce interface:

- 1 Press Command-Tab/Ctrl+Tab. All the palettes disappear and your image appears at the center of your work space.
- 2 Press Command-Tab/Ctrl+Tab again to display all the palettes.

To display individual palettes:

- 1 Press Command-Tab/Ctrl+Tab to hide the interface.
- 2 Press the key combination for the palette you want to display:
 - Command-1/Ctrl+1=Create palette
 - Command-2/Ctrl+2=Edit palette
 - Command-3/Ctrl+3=Sky&Fog palette
 - Command-4/Ctrl+4=Control palette
 - Command-5/Ctrl+5=Selection palette
 - Command-6/Ctrl+6=Display palette

Displaying Text Information

The Text Display area at the bottom of the Control palette displays a great deal of valuable information about the interface and statistics for your scene.

During rendering, the Text Display area displays projected and elapsed time estimates. This estimate does not include the time for anti-aliasing. The total time, including anti-aliasing, will be calculated and displayed in the Render Report.

When you're working in the Timeline or Animation controls, the Text Display area displays the current time.

To display information about the interface:

- Pass the pointer over any interface element.
The name of the element is displayed. In some cases, the element's current settings are also displayed.

To display statistics about the objects in your scene:

- 1 Switch to Wireframe display using the Display Mode tool.
- 2 Pass the pointer over the working window.
 - If no objects are selected, the Text Display area displays a count of all of the objects in your scene, as well as a total polygon count.
 - If an object is selected, the Text Display area displays object and polygon counts for the selected object.

To display information about rendered images:

- 1 Switch to bitmap display mode using the Display Mode tool.
If you have not rendered your image, the working window is blank.
- 2 Pass the pointer over the working window.
The Text Display area shows the file size.

Displaying/Hiding Palettes

To keep the interface uncluttered, many of Bryce's palettes and toolbars are hidden when you first launch the application. Some palettes are hidden behind other palettes.

To display different palettes:

- Either click on a text button above the Working window or press the key combination for the desired palette:
 - Command-1/Ctrl+1=Create palette
 - Command-2/Ctrl+2=Edit palette

- Command-3/Ctrl+3=Sky&Fog palette
- Command-4/Ctrl+4=Control palette

To display hidden palettes:

- Pass the cursor over the edges of the Working window, or
- Press the key combination for the hidden palette you want to display:
 - Command-6/Ctrl+6=Display palette

Displaying Submenus and Pop-up Dialogs

Wherever you see an inverted or sideways triangle icon in the interface, it indicates that there is a menu or other item available that contains options pertinent to the item closest to it. For example, in the Create palette, there are triangle icons next to each tool in the palette. These triangles access the additional options for the tools.

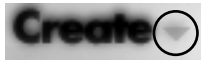

The triangle icon next to a tool or text button indicates that there are more options available for the element.

To display a submenu:

- Click the triangle icon.



Click the triangle icon next to a tool to access additional options.

Working with Documents

Before you can create a Bryce environment you need a document. A document can be either a blank scene or an existing file that you're going to edit.

Creating an Empty Scene

When you create a blank scene, Bryce opens the Document Setup dialog which lets you specify the aspect ratio and dimensions of the new scene.

To create a new document:

- 1 Choose **File menu**> **New**. The Document Setup dialog appears.

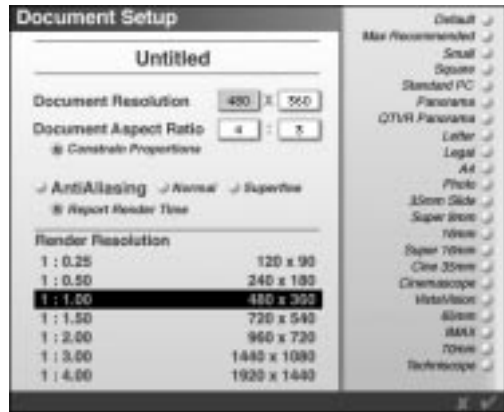

Use the Document Setup dialog to set the resolution and aspect ratio for your image.

- a.
- 2 Enter values in the Document Resolution fields.

This is the absolute size of your working space expressed in pixels. You can enter

any values you like here, though it's recommended that you not exceed your available screen space if you can avoid it. You can work small and render large if you need to. The values in the Aspect Ratio fields will update automatically as needed.

- 3 Enter values in the Document Aspect Ratio fields.

These fields represent the Document Resolution as a ratio. Depending on the type of work you are doing, it may be more convenient to enter values here rather than in the resolution fields above. For instance, many video formats, as well as the standard 13" screen, are 3:4 aspect ratios.

The values in the Document Resolution fields will update automatically if you change the aspect ratio.

- 4 Enable the Constrain Proportions button if you want to preserve the current aspect ratio as you adjust the resolution.
- 5 Select a Render Resolution from the list.

This resolution sets the absolute size of your rendered image, expressed in pixels as a multiple of your document size.

You may be working at Bryce's default size as you build your scene, but you may then wish to render that scene four times larger for print or four times smaller for a web page. Rather than resetting your document resolution every time you render, impacting your wireframe workspace, you can simply set a separate size for rendering. Think of Document Resolution as input, and Render Resolution as output.

The default resolution is 480 x 360, and the default aspect ratio is 4:3.

To set up a new document using presets:

- 1 Choose **File menu**> **New Document**. The Document Setup dialog appears.
- 2 Click one of the preset aspect ratios displayed along the right side of the dialog. These presets are aspect ratios for many useful document types. The pixel values that are placed in the Document Resolution fields are either absolute (as in Legal or Letter) or based on your available screen resolution (as in Maximum Recommended or Square).

Opening an Existing File

Bryce can open any file created in any previous version of Bryce (Mac or PC).

To open an existing file:

- 1 Choose **File menu**> **Open**.
- 2 Use the dialog controls to locate and open your file.

Merging scenes

You can merge two Bryce scenes using the Merge command. When you use this command the scene you open is merged with the currently open scene. Objects from the scene you're opening are placed in your current scene, at the same absolute coordinates that they previously occupied.

To merge two scenes:

- 1 Choose **File menu**> **Merge**. A dialog appears prompting you to save the current scene.
- 2 Click Save. The Open dialog appears.

- 3 Use the dialog controls to locate the file you want to merge and click Open.

The file you selected is merged with the current scene.

Holding down the Option/Alt key while performing this function will merge only the sky from the incoming scene.

Working in a Scene

Displaying Your Scene

The display of your scene is controlled by the display mode you selected when you set up the Working window. You can also control how individual objects are displayed and how your scene is displayed in the Nano-Preview.

Changing Object Display

You can change how your objects are displayed using the Object menu commands. Changing the object preview can greatly reduce redraw time in a complex scene. The Object's preview does not affect how the object renders.

To display objects as boxes:

- 1 Choose **Object menu > Show Object as Box**.

This command displays any selected object, objects, or group as box(es). This is useful when you just want to work with the object's position, but don't need more details.

Keyboard Shortcut: Command-B/Ctrl+B.

To display objects as wireframes:

- Choose **Object menu > Show Object as Lattice**.

Use this command to change objects shown as boxes back to wireframes.

Keyboard Shortcut: Command-L/Ctrl+L.

Using the Nano-Preview

The Nano-Preview is where your object is displayed before you render it. The preview can display your scene from a number of different angles without affecting the position of the camera.

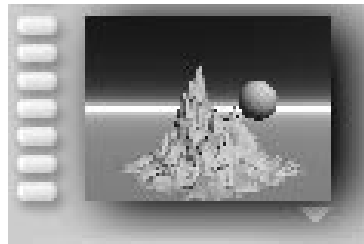

The Nano-Preview displays a rendered preview of your scene.

To display your scene from different angles in the Nano-Preview:

- Click the triangle icon below the Nano-Preview and choose a preset display angle.



Click the triangle icon to access the display angles for the Nano-Preview.

The view of your scene does not change in the Working window.

To set Nano-Preview options:

- Click the triangle icon below the Nano-Preview and choose a display option:
 - Sky Only previews only your sky settings.
 - Full Scene previews your actual scene. This is the default setting for the Nano-Preview.
 - Wireframe Only previews your wireframes only, as opposed to a rendered preview.
 - Auto Update will automatically update the preview render with every single change you make during your session. In most cases, this is a godsend, giving you almost immediate feedback after any action. On slower machines, or when working with highly complex scenes, you may wish to deselect this option.

With this option deselected, you'll need to click in the Nano-Preview window to update the render.

- Select either Fast Preview or Full Rendering to adjust the quality of the rendered preview. With Full Render selected, every pixel is raytraced and anti-aliased. Fast preview mode skips pixels to achieve faster updates. This may cause small objects to be partially or completely missing.

Using the Movie Preview

In addition to viewing still images in the nano-preview window, you can use the same window to see a small version of your animation, without having to leave Bryce.

See "Previewing Animations" on page 363. for more information.

Viewing Your Scene

When you're creating an environment in Bryce, your scene can quickly become rather large. You may not be able to see the entire landscape in the Working window. Bryce has several tools that can help you see every inch of your new world.

Orthogonality and Views

When you view a scene from the side, front, top, or bottom using the Camera, you'll see certain amounts of perspective distortions. These distortions can make precise visual alignments difficult.

For instance, if you have a dozen cubes in different locations, and go to Top View to place them on top of one another, you will find it very difficult. Cubes further from the camera would be slightly smaller than cubes close to the camera, resulting in a confusing array of lines. The more complex the scene, the more confusing and difficult this kind of alignment becomes.

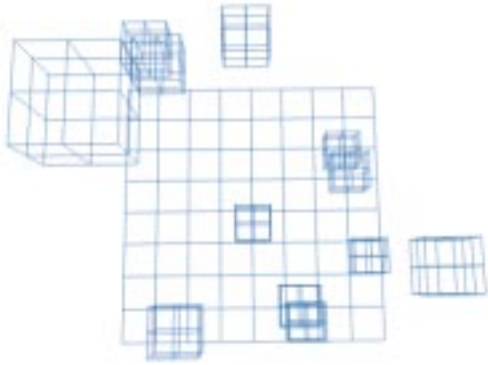

If you viewed objects from above through a real-world camera, the perspective distortions would make alignment or placement difficult.

To solve this problem, Bryce uses a perspective-free, *drafting board* kind of view in which like-sized objects far away appear exactly the same as those up close.

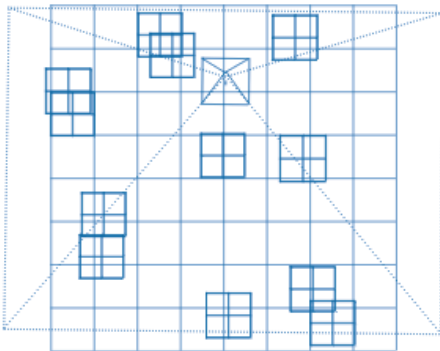

Bryce uses an “orthogonal projection” of your objects to eliminate perspective distortion.

This perspective-free view is called an *orthogonal projection*. In Bryce, all views other than your Main View (that is, Top, Bottom, Right, Left, Front, and Back) are orthogonal projections. They are not generated by the

camera, and so do not contain the perspective distortion that would necessarily come with a camera view.

As a result, Camera controls do not work in these views. You can navigate within the orthogonal views using the Zoom and Pan tools.

If you press the Render button while in an orthogonal view, Bryce will quickly set up the camera position you need and render your image. There may be slight differences between what you see in the wireframe projection and what you see in the rendered image, as a result of the added perspective distortion in the rendered image.

Zooming In and Out

In Bryce there is a difference between moving the camera and using the zoom tools.

When you move the Camera, you’re moving in 3D space. When you use the pan and zoom controls, you’re transforming a 2D projection of your 3D scene—your camera position does not change.

When you use the Zoom tool, you are essentially making the 2D projection larger or smaller. Your camera position in 3D space does not change.

To zoom in:

- Click on the Zoom In tool.



Bryce scales the 2D projection of your scene larger, creating the illusion of zooming into your 3D scene; your camera position remains unchanged.

Keyboard Shortcut: Command-plus/
Ctrl+plus.

To zoom out:

- Click the Zoom Out tool.



Bryce scales the 2D projection of your scene smaller, creating the illusion of zooming out of your 3D scene. Your camera position remains unchanged.

Keyboard Shortcut: Command-minus/
Ctrl+minus.

To zoom into an area:

- Hold down Command-Spacebar/
Ctrl+Spacebar and drag a marquee around an area of your scene.
Your cursor changes to a Zoom tool, and Bryce centers and scales up the area in the marquee to fit your window.

To zoom out of an area:

- Hold down Command-Option-Spacebar/
Ctrl+Alt+Spacebar and drag around an area.
Bryce scales down your entire scene to fit within the area your marquee selected.

To zoom numerically:

- 1 Double-click the Trackball in the Control palette. The Camera & 2D Projection dialog appears.
- 2 Enter a value in the Scale field.
The default value is 100%.

To reset the zoom value:

- Press the Option/Alt key and click the Zoom tool.

The view of your scene resets to 100%.

Panning

Panning works exactly like zooming. When you use the Panning tool, you are moving a 2D projection of your scene right and left, up and down, in front of the camera. Your camera position in 3D space does not change.

To pan your scene using the Pan tool:

- Drag over the Pan tool in the direction you want your scene to move.

To pan your scene using the Spacebar:

- Hold down the Spacebar and drag in the direction you want your scene to move.

To pan numerically:

- 1 Double-click the Trackball in the Control palette. The Camera & 2D Projection dialog appears.
- 2 Enter a value in the Horizontal field.
The default value is 0.
- 3 Enter a value in the Vertical field.
The default value is 0.

Using Fly-around View

You may have noticed a tiny circular icon above and to the right of the Views icon. If you click here, you will change from your current View to a special *motion view*, or Fly-around View.



In Fly-around view your scene rotates so you can see it from a number of angles.

This view enables you to get a sense of context in your Bryce world. If you're working close to the ground, or stuck in the midst of a clump of trees, or you've lost a cube you know you created a half an hour ago, you can use the Fly-around view to see your entire scene all at once.

In Fly-around view, Bryce positions the Camera on an imaginary monorail track above and away from your scene such that you can see the whole scene from all sides as the camera moves around it.

To switch to Fly-around view:

- Click the Fly-around view icon next to the View control. The View control icon changes to the Fly-around control icon.



To switch back to Camera view:

- Click on the Fly-around view icon again.

To rotate the view of your scene in Fly-around view:

- Move your mouse in the direction you want to rotate. The scene rotates in the direction you drag.

To zoom in and out in Fly-around view:

- Hold down the Command/Ctrl key.

To pause the Fly-around:

- Press the Spacebar.

To end the Fly-around and save Fly-around position:

- Press Return/Enter. The view switches back to Camera view and the last Fly-around position becomes the new Camera View.

Keyboard Shortcut: Command-Y/Ctrl+Y.

Using the View Control

Bryce lets you view your scene from several preset positions; Main, Top, Front, and Side, Bottom, Right, Left, and Back. All these views with the exception of the Main View are special Orthogonal projections which allow perspective-free views well-suited for alignment operations.

The View control is an interactive way of cycling through the various preset views. The current position of the View control indicates the view you're seeing in the Working window.

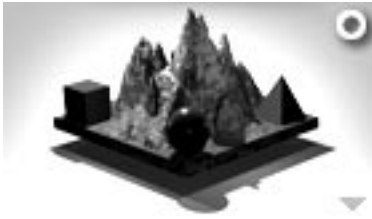

The View Control lets you select from different views of your scene.

To switch views using the View control:

- Click or drag the Views control until you reach the view you are looking for.
Every time you click the control Bryce displays a different preset view.

To switch views using the View control menu:

- Click the triangle icon next to the View control and select a view option:
 - **Camera View:** select this option to view your scene as the Camera sees it, based on the Camera's current location and orientation.
 - **From Top:** select this option to view a perspective-free orthogonal projection of your scene as seen from above (based on absolute world coordinates).
 - **From Right:** select this option to view a perspective-free orthogonal projection of your scene as seen from the right (based on absolute world coordinates).
 - **From Front:** select this option to view a perspective-free orthogonal projection of your scene as seen from the front (based on absolute world coordinates).

- **From Left:** select this option to view a perspective-free orthogonal projection of your scene as seen from the left (based on absolute world coordinates).
- **From Back:** select this option to view a perspective-free orthogonal projection of your scene as seen from behind (based on absolute world coordinates).
- **From Bottom:** select this option to view a perspective-free orthogonal projection of your scene as seen from below (based on absolute world coordinates).
- **Director's View:** select this option to view your scene from the perspective of a director sitting outside the scene.

To switch views using the keyboard:

- Select a preset view shortcut:
 - Camera View=1
 - Top View=2
 - Right View=3
 - Front View=4
 - Director's View=~

To reset the view of your scene:

- Click the triangle icon next to the View control and choose Reset Views, or
- Press the Option/Alt key and click on the Views icon.
This option resets your View to Bryce's default setting.

Selecting Objects

Before you can perform any type of editing or transforming operation on an object, you need to select it. Besides selecting objects using the cursor, Bryce's Selection tools let you select objects by type or family. You can also cycle through all the objects in your scene.

To select an object:

- Click on any object. A selected object's wireframe will appear red, or
- Drag a marquee around the object.

To select a number of objects:

- Drag a marquee around a number of objects.

To step through all the objects in your scene:

- Press the Tab key until the object you want selected appears in red.

To select all objects:

- Choose **Edit menu> Select All**, or
- Press **Command-A/Ctrl+A**.

To select an object within a group:

- Hold down Control and click the desired object.

To deselect all:

- Choose **Edit menu> Deselect All**, or
- Click anywhere outside the selected area.

To add objects to a selection:

- Hold down the Shift key while selecting the object.

To remove objects from a selection:

- Shift-click the selected object.

To select obscured objects:

- 1 Hold down the Shift key and select through the obscuring object. All objects underneath the cursor and behind the frontmost object will be selected, or

Drag a marquee around the objects.

- 2 Hold Cntrl/Cmd and click an object to select or deselect. Use shift to select multiple objects.

You will see a list of all objects under the pointer. This lets you not only view the selection status of all the listed objects, but change it as well. This aids in dealing with large scenes.

The Selection Palette

The Selection palette is hidden behind the Animation controls in Bryce's default state. The palette is divided into two sections: select by type tools and the VCR controls.



The Selection palette has tools for selecting objects in variety of different ways.

To display the Selection palette:

- Click the Time Selection Palette toggle in the lower right corner of the Working window. The Selection palette appears.



Click the Time Selection Palette toggle to switch between the Animation and Selection palettes.

Selecting By Object Type

The Select by Type icons let you select all the objects in your scene that are of a particular type. For instance, if you click on a sphere here, Bryce will select all spheres and sphere-derivative objects in your scene.

All of the selection controls below respect the previously-described Shift-click techniques for multiple selections and deselections.

The following tools are available:



Selects all Infinite slabs.



Selects all Water, Cloud, and Ground planes.



Selects all Terrain objects.



Selects all Stone and Mesh objects.



Selects all Symmetrical Lattice objects.



Selects all Torus objects.



Selects all Spheres, Ellipsoids, and Squashed Spheres objects.



Selects all Cylinder, Tuboid, Squashed Cylinder, and Stretched Cylinder objects.



Selects all Cube, Brickoid, and Stretched Cube objects.



Selects all Pyramid objects.



Selects all Cone, Stretched Cone, and Squashed Cone objects.



Selects all 2D Disk objects.



Selects all 2D Face and 2D PICT objects.



Selects all Radial Light objects.



Selects all Spotlight objects.



Selects all Square Spotlight objects.



Selects all Parallel Light objects.

To select a specific object by type:

- Hold down the cursor over the tool for the type of object you want to select and choose the name of the object from the menu that appears.

You must first name objects, if you want them to appear in this menu. Refer to “Naming Objects” on page 101 for more on naming objects.

To select objects by family:

- Click the Families tool and choose the name of the family you want to select from the menu.

You must first name a family if you want it to appear in this menu. Refer to “Families” on page 310 for more information.

To select Mesh objects:

- Click the triangle icon next to the selections palette and choose Select Mesh.

To select Path objects:

- Click the triangle icon next to the selections palette and choose Select Path.

To select Group objects:

- Click the triangle icon next to the selections palette and choose Select Group.

To select all objects except a specific type:

- 1 Click the tool for the object you want to exclude from the selection. All the objects of that type are selected.
- 2 Click the triangle icon in the Selection palette and choose Select Inverse from the menu.

To select all the objects in your scene:

- Click the triangle icon in the Selection palette and choose Select All from the menu.

The VCR Controls

The VCR controls let you step through the various selection tools and activate Solo Mode.



To display the VCR Controls:

- 1 Click the Time Selection Palette toggle in the lower right corner of the Working window. The Selection palette appears.
- 2 Pass your cursor over the right side of the Selection palette. The VCR Controls appear.

To step forward and backward through the object types in your scene:

- 1 Click on the larger forward arrow to step forward through object types within the current scene. The first object of its type is selected.



- 2 Click on the larger backward arrow to step back through object types.



If you watch the Select By Type icons, the object type you are stepping to will highlight momentarily.

To step forward and backwards through the object in a selected object type:

- 1 Click on the smaller forward arrow to step forward through each object of the type in a selection.



For example, you can use the large arrows to step to the first sphere created in your scene, and then the smaller arrows to step through all other spheres in your scene.

- 2 Click the smaller backwards arrow to step backwards through each object of the type in a selection.



One advantage to making selections with this technique is that you can select objects within a Group. Simply clicking on a Grouped object will not necessarily select the entire group; using the VCR controls to select within a Group allows you to reposition objects, or assign textures to objects within a Group without having to first Ungroup them.

To step sequentially through every object in your scene:

- 1 Click the triangle icon in the Selection palette and choose Alternate VCR Mode.
- 2 Click the larger backwards or forwards arrow.

To step sequentially through families:

- 1 Click the triangle icon in the selection palette and choose Alternate VCR Mode.
- 2 Click the smaller backwards or forwards arrow.

To temporarily remove all unselected objects from the scene:

- 1 Select an object.
- 2 Click the Solo Mode button in the center of the VCR controls. The button color changes to red.



In Solo Mode, you can only edit the selected objects; all the other objects remain in place but uneditable.

If you're working on a very complex scene, Solo Mode speeds up your work significantly as Bryce does not have to calculate and draw extraneous wireframe objects.

Editing Your Scene's Contents

Bryce supports several of the basic editing features you find in most applications. You can cut, copy and paste objects between the clipboard and your scene.

Cutting and Pasting Objects

To cut and paste an object:

- 1 Select an object.
- 2 Choose **Edit menu> Cut**, or Press **Command-X/Ctrl+X**.
The selected item is removed from your scene and placed on the clipboard.
- 3 Choose **Edit menu> Paste**, or press **Command-V/Ctrl+V**.

To copy and paste an object:

- 1 Select an object.
- 2 Choose **Edit menu> Copy**, or press **Command-C/Ctrl+C**.
A copy of the selected item is placed on the clipboard.
- 3 Choose **Edit menu> Paste**, or press **Command-V/Ctrl+V**.

Copying and Pasting Materials

Using the Copy/Paste Material commands, you can edit an object's material without affecting the object.

To copy and paste an object's material:

- 1 Select an object.
- 2 Choose **Edit menu> Copy Material**, or press Command-Option-C/Ctrl+Alt+C.
The selected item's material is copied to the clipboard.
- 3 Choose **Edit menu> Paste Material**, or, press Command-Option-V/Ctrl+Alt+V.

Copying and Pasting Matrices

Using the Copy/Paste Matrix commands, you can copy information about an object's location, size and orientation values to the clipboard and then paste them onto other objects.

To copy and paste an object's matrix:

- 1 Select an object.
- 2 Choose **Edit menu> Copy Matrix** or press Option-C/Alt+C.
The selected object's matrix is copied to the clipboard.
- 3 Select a different object.
- 4 Choose **Edit menu> Paste Matrix** or press Option-V/Alt+V.

To delete a selected object:

- 1 Select an object.
- 2 Choose **Edit menu> Clear** or press the Delete/Backspace key.

Duplicating and Replicating Objects

When you duplicate an object, Bryce creates an exact copy of the object and places it in exactly the same position as the original. When you replicate an object, Bryce creates a new object and applies the last set of transformations to it.

To duplicate an object:

- 1 Select an object.
- 2 Choose **Edit menu> Duplicate** or press Command-D/Ctrl+D.

To replicate an object:

- 1 Select an object.
- 2 Choose **Edit menu> Replicate** or press Option-D/Alt+D.
A new object appears at a size, location and orientation based on the last set of transformations. For example, if you select an object, drag it to a new location and then select Replicate, a new object is created at the same distance from the original.

To replicate objects numerically:

- 1 Select an object.
- 2 Choose **Edit menu> Multi-Replicate** or press Command-Option-Shift-D/Alt+Shift+D.
The Multi-Replicate dialog appears.
- 3 Enter a value in the Quantity field.
This value sets the number of duplicates you want to create.
- 4 Enter X, Y and Z values in the Offset fields.

Offset values are expressed in a range from 0 to 99999 Bryce units of measure (refer to “Bryce Units” on page 282 for more on Bryce units). The default value is zero.

- 5 Enter X, Y and Z values in the Rotate fields.

Rotate values are expressed as degrees, with a range of 0 to 999. The default value is zero.

- 6 Enter X, Y and Z values in the Scale fields.
Size values are expressed as a percentage of current size, with a range of 0 to 9999%. The default value is 100%.

The Quantity value entered in this dialog sets the number of duplicates created when you use the Replicate command.

Undoing Operations

The Undo and Revert to Saved commands let you erase the effects of changes you made to your scene.

To undo the last operation:

- Choose **Edit menu**> **Undo** or press Command-Z/Ctrl+Z.

To redo the last operation:

- Choose **Edit menu**> **Redo**.

To revert to the last saved version of your scene:

- Choose **File menu**> **Revert to Saved**. All unsaved changes are discarded.

The Marker Pen

The Marker Pen turns your screen into a white board. When you’re using the Marker Pen, you can draw anywhere in the Bryce environment without affecting your scene. One key click erases all the marker pen lines.

To draw with the marker tool:

- 1 Click the Marker Pen tool or press the M key.



- 2 Drag it anywhere on your screen.

To erase marker pen lines:

- Click the Marker Pen tool again or press the M key again.

Saving and Closing

The Save command lets you save your work in a convenient location for later use. Since your scene files can quickly become large and complex, you should save your work often.

Saving Files

To save a file:

- 1 Chose **File menu**> **Save**. The Save dialog appears.
- 2 Use the dialog controls to choose a location for your work and click Save.

To save a file under a different name:

- 1 Chose **File menu**> **Save As**. The Save dialog appears.
- 2 Enter a new name and/or location in the fields provided and click Save.
- 3 A copy of your work is saved, leaving the original intact.

If the Image With Scene Open/Save preference is selected, Bryce saves both the scene data and the rendered image when it saves the file.

Closing

When you close the application, a dialog appears asking you to save your work.

To close Bryce:

- Choose **File menu**> **Quit** or press Command-Q/Ctrl+Q.



4

Animation in Bryce

Animation Overview

Animation is the process of adding a fourth dimension to your scene—time. To create an animation, you arrange a scene then record your movements or transformations of objects over time. Bryce creates a motion path from your recorded movements and then generates an animation.

You can animate almost anything in your scene:

- the motion of objects, lights, and the camera
- object size and shape
- object materials
- terrain objects
- sky properties

The Animation Process

Animation is a cooperative process between you and Bryce. You set up the arrangement of objects and scene settings, and then you adjust those settings over time. Bryce steps in and fills in the gaps between adjustments. When you play the animation, motion is created.

The steps to creating an animation are as follows:

- Create objects using the Create tools or the Terrain Editor.
- Build a scene by arranging and transforming objects, lights and the camera.
- Adjust the position, orientation or scale of objects. Each time you make an adjustment, you create a *key event* which indicates a point where an object property was changed.
- Adjust the shape or placement of the motion path.
- Adjust the speed at which the object moves along the motion path using the Advanced Motion Lab.
- Render the animation as a movie file. You can render the animation as a QuickTime/AVI movie file or as a set of frames.

Animation Tools

Bryce 3D's animation tools are designed to help you quickly and easily animate the properties of your scene.

Animation Controls

The animation controls let you record an animation and preview it in the Working Window.

You can also use the controls to change the current time or move to different points in time.

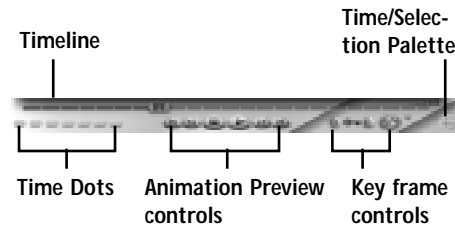

Use the animation controls to record and preview your animation.

The Animation controls appears in three areas in Bryce:

- The Working Window
- The Materials Lab
- The Terrain Editor
- The Sky Lab

The tools have basically the same function in each area. The only difference is that controls in the editors let you create key events for the properties associated with the editor. This means that in the Terrain Editor you can only add key events for terrain objects, and in the Materials Lab you can only add key events for material properties.

The Timeline

The Timeline is a graphical representation of time. The darker gray area within the Timeline represents the current length of your animation.

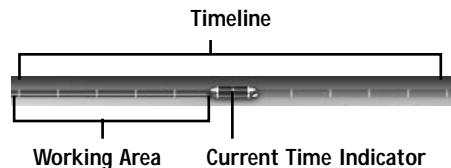

The Timeline indicates the length of your animation and the current time.

The green colored section of the timeline represents the length of the Working Area. The Working Area can be used as a visual guide to help you isolate portions of your timeline. When you render the animation you can choose to render the entire timeline or just the Working Area. This is also the only area that is previewed when you use the animation preview controls.

The Current Time indicator lets you move to different points in time. This is the main tool you'll use to create animations. Every time you want to add a key event, you move the Current Time indicator to a different point on the timeline.

Animation Preview Controls

The Animation Preview controls let you move between the key frames in your animation.

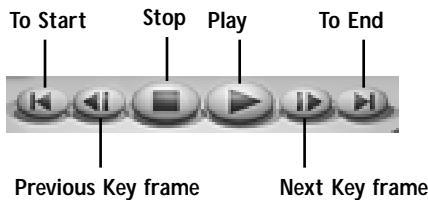

Use the Animation Preview Controls to move between key frames in your animation.

The larger buttons move to the beginning and the end of the animation. The smaller buttons move to the next and previous key frames.

Using the Movie Preview

In addition to viewing still images in the nano-preview window, you can use the same window to see a movie preview. Used this way, the movie preview window provides a simple, quick, way to see a rendered version of your animation without having to leave Bryce.

See “Previewing Animations” on page 363. for more information.

Time Dots

The Time Dots let you save positions on the timeline. You can use the dots to quickly jump between areas of the timeline you're working on.



Use the Time dots to quickly move between saved positions along the timeline.

Key Frame Controls

The Key Frame controls let you add and delete key frames in your animation.

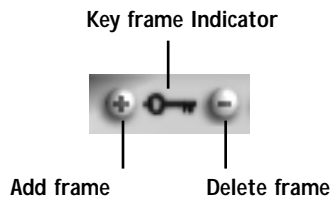

Use the Key Frame controls to add and delete key frames from the timeline.

The Key frame indicator is only active when the current time is at a key frame.

The Add Key frame (plus) button lets you add a key frame. When you are in Camera View, with nothing selected, Add frame automatically key frames the camera. In Director's view, it does not. It also keys the sky.

In Auto-Key mode, Bryce automatically adds key frames for you, but when you disable the mode, you'll have to use Add Key frame to add key frames at points in the timeline.

The Delete Key button deletes the current key frame event or a specific type of key event. In

the Working Window, deleting a key event deletes all the frames at the current time. In the editors the Delete Key button only deletes key events for the properties associated with the editor.

Animation Options

The triangle icon to the right of the animation controls, displays Auto-Key Framing option menu. This menu lets you turn the animation system on or off.



Use the triangle icon to access the animation options menu which lets you enable or disable the animation system.

When the animation system is enabled, every change you make to the scene is recorded as a key event. Changes can include things like moving an object, changing a material, or changing the shape of a terrain.

When the animation system is disabled, your changes are not recorded. To record a key event you have to use the Add Key Frame button. The animation system is enabled by default.

This menu also contains the following:

- Ticker Marks lets you select from frame or time options.
- Play mode lets you choose Once, Repeat, or Pendulum.
- Time display is either SMPTE or Frame.

Time/Selection Palette Toggle

The Time/Selection Palette toggle lets you switch between the Animation controls and the Selection palette.



Use the Time/Selection Palette toggle to switch between palettes.

Advanced Motion Lab Button

The Advanced Motion Lab button opens the Advanced Motion Lab.



Use the Advanced Motion Lab button to enter the Advanced Motion Lab.

The Advanced Motion Lab

The Advanced Motion Lab contains tools that let you control the detailed properties of your animation. You can use the lab to view object hierarchies, remap key events and adjust the position of key frames on the timeline.

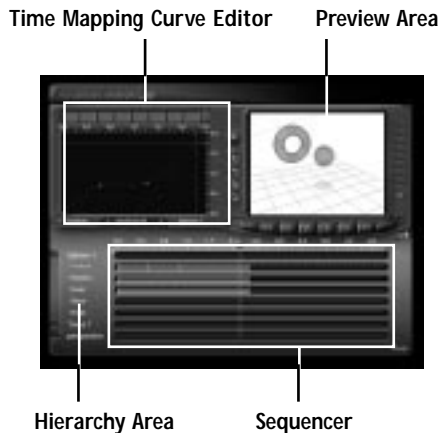

The Advanced Motion Lab lets you control the speed of objects along a motion path and the placement of key frames on the timeline.

Hierarchy List Area

The Hierarchy List Area displays the scene's hierarchical structure, including links, and groups. You can view all the hierarchies expanded or just the parent objects in the scene. You can also expand an object's listing to show all of its properties.

The Sequencer

The Sequencer lets you see the key frames recorded for each property within an object. Each property has its own timeline *track*. Key frames are displayed as white marks on the

timeline. The current time is indicated by the Current Time bar.

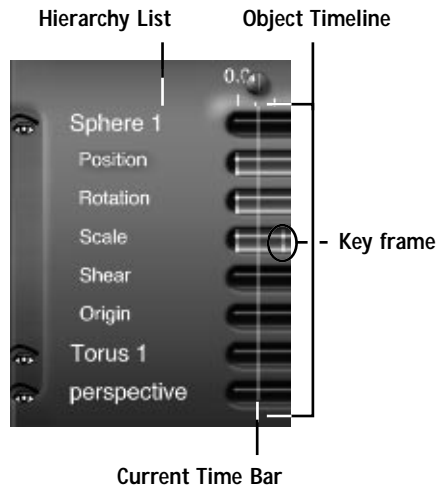

The Sequencer lets you control the placement of key events on the timeline.

The Sequencer lets you see where in time a change in an object's property occurred and edit the position of that event. Different types of objects have different properties.

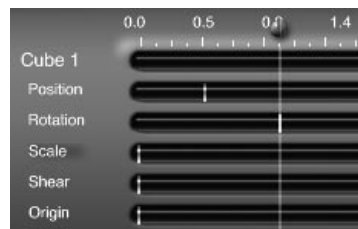

Each Object listed in the Hierarchy List area can be expanded to show the timelines of any transformations applied to it.

A scene contains more than just objects. You can expand the Hierarchy List to also display the properties for your scene's sky and the camera.

The display buttons along the left side of the hierarchy area let you hide or display an object in the animation preview. This can help you isolate objects in a complex scene.



Use the display buttons to hide or show objects in the animation preview.

Time Mapping Curve Editor

The Time Mapping Curve editor lets you control the length of time between key events. Each property listing in the Hierarchy List has its own time mapping curve.

The curve acts like a time filter which remaps the time in your animation. Depending on the shape of the curve, the events in your animation may take longer to complete, or may all occur very rapidly.

A time mapping curve can speed up events while slowing down others. You can even reverse the action in your animation. Refer to “Time Mapping Curves” on page 371 for more on working with Time Mapping Curves.

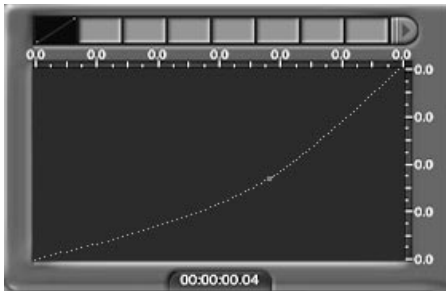

The Time Mapping Curve editor lets you remap the time in your animation.

Preview Area

The Preview Area contains tools that let you preview your animation.

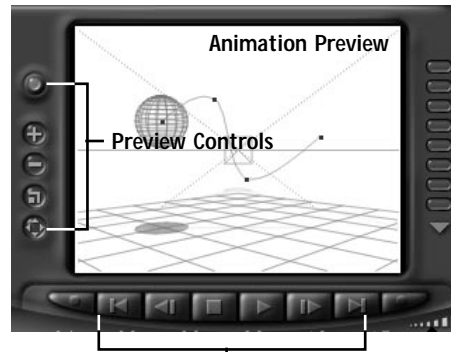

Preview VCR Controls

The Animation Preview area lets you see any changes you make to the timing and velocity of objects.

The Preview Area has three parts:

- The Animation Preview area displays a wireframe preview of your scene. Any changes you make in the Time Mapping Curve editor or the Sequencer are updated to this area.
- The Preview VCR controls let you play the animation like a movie. You can stop, play, move forward one key frame, or back one. The far right button renders the scene.
- The Preview Display Controls let you zoom in/out of the preview, switch between Camera View and Director View, pan the preview and reset the preview.

Animation Features

Bryce has several special features that let you add extra effects to your animations:

- Time Mapping Curves
- Animating Transformations
- Animating Materials
- Animating Terrains
- Animating Skies

Time Mapping Curves

Time Mapping Curves are graphical representations of the time mapping filter. The filter remaps the time in your animation, so that the events that occur at specific times in your animation occur differently in actual time.

By adjusting the shape of the curve, you can control how fast events occur. When you create a sharp jump in the curve, you speed up the events in your animation. When you flatten the curve, you slow down key events.

Each property of your scene can have a different curve, so you can have key events occurring at different speeds.

Refer to “Time Mapping Curves” on page 43 for more on Time Mapping Curves.

Animating Transformations

When you’re in Auto-Key mode, every transformation you apply to an object is recorded as a key frame.

In the Hierarchy area you can see where the key frames for these transformations appear in the timeline. By moving these key frames you can control the order in which transformations are applied. For example, you can take an object that grows larger and then moves left, and turn

it into an object that moves left and then grows. Several animation techniques, like squash and stretch, can be simulated using transformations.

Refer to “Animating Transformations” on page 43 for more on animating transformations.

Animating Materials

The Materials Lab has its own set of animation tools that let you animate material properties. You can animate almost any property or texture.

When you’re animating between textures, Bryce interpolates between patterns and colors over time. You can have a rocky terrain turn into a desert during the course of your animation.

Refer to “Animating Materials” on page 388 for more on animating materials.

Animating Terrains

The Terrain Editor has a set of animation tools that let you animate a terrain over time. You can animate the shape of the terrain, or the filtering effects like Erosion or Mounds.

Using these tools, you can create a terrain that changes shape as time passes.

Refer to “Animating Terrains” on page 396 for more on animating terrains.

Animating Skies

The Sky & Fog palette and the Environmental Attributes dialog have a number of controls that let you set the properties of your environment. By changing these properties over the course of an animation, you can animate your environment. For examples, you can make clouds move, or gradually change the time of day.

Refer to “Animating Skies” on page 393 for more on animating skies.

Managing Your Project

Storyboarding

If you are attempting anything other than a brief animation, it’s a good idea to create a storyboard first. A *storyboard* is a series of drawn images showing the key actions in an animation. The storyboard helps you quickly work out the animations viewpoint, framing and composition. Because you’re just sketching, it’s easy to make changes and other arrangements. Your work on the storyboard will give you an idea of the types of objects you’ll need to model and how to arrange the scene.

You can make sample storyboards by drawing a series of horizontal screen outlines on a sheet of paper, using a 4 to 3 aspect ratio (ratio of width to height). Draw the screens as large as necessary, and leave a block of space for the narration or description. You can also purchase cartooning storyboards at art supply stores.



You can use a storyboard to help layout the action in your animation.

Storyboard Preview

You can see a storyboard preview of your animation. See “Previewing Animations” on page 363. for more information

Simplifying Your Scenes

In general, the 3D scenes you create for animation need not be as complex as a typical illustration scene. The viewer’s eye tends to be drawn toward motion and foreground elements. Static objects and background elements are scanned only casually.

By reducing unnecessary detail, you can reduce rendering times dramatically and keep the size

of your scene files manageable. When preparing a scene for animation, keep the following guidelines in mind:

- Refine your animation. Keep the objects as simple as possible. Detail is usually lost in an animation.
- Use fewer objects, and limit the number of reflective and transparent objects.
- Use the minimum number of lights required to achieve an effect. Additional light adds significantly to the rendering time.
- Limit the number of objects with complex materials.
- If a complex model remains in the background for the duration of the animation, try substituting a simpler version.
- If your Camera View remains unchanged for an entire scene, consider rendering a still image with just the scene's background elements. Then use this image as a backdrop and animate only the foreground elements. This technique requires some planning to make sure that shadows and transparent objects don't give the "trick" away.

Rendering Without Compression

If you are not pressed for hard disk space, it usually makes sense to render your animation without compression. This ensures that you'll have a high quality copy of the animation to work with.

Working from your uncompressed original, you can save copies, experimenting with various compression settings until you are satisfied with both the image quality and playback rate.

An animation compressed multiple times degrades significantly, so you should always

render without compression if you intend to do any postprocessing in another application.

Motion and Timing Principles

As an animator, the most important skill you can master is the ability to portray motion convincingly, whether it is intended to be realistic or exaggerated and cartoonish. No matter how good a 3D modeler you are, the timing of the events in your animation are of paramount importance.

Many of the principles of timing and motion developed by cell animators apply to 3D animation with Bryce as well. Many of these principles apply especially to character animation, but most are useful for any subject matter. For more information, you can refer to one of the many excellent books on cartoon animation.

Squash and Stretch

Squash and stretch are animator's terms for the exaggerated redistribution of an object's mass as it moves or shifts positions. Squash and stretch portray the qualities of elasticity and weight in a character or an object.

Think of a bouncing rubber ball. As it falls it stretches; as soon as it hits the ground it is squashed. If the ball failed to change shape, the audience would interpret it as a solid, rigid mass.

You can accomplish squash and stretch in Bryce by transforming the object at different points in time.



This ball's bouncing motion is exaggerated by deforming its shape so that it stretches as its descending and squashes when it hit the surface.

Lag and Overlap

When an object moves from one point to another, not everything has to move at once. For true-to-life movement, action that is secondary to the main activity can lag and overlap. For example, when you animate swirling curves, the cubes at the top would swirl faster than those at the bottom. In Bryce, an object's hierarchy can be used to create these effects.

Arc vs. Straight Line Movement

Character motion appears more realistic if it follows an arc or curved path instead of a straight line. Most objects affected by gravity also follow curved, rather than straight trajectories.

Bryce's motion paths can be used to create any type of trajectory.

Secondary Motion

Secondary motion adds realism and credibility to a scene. A character turning his head to stare at something in disbelief shouldn't just turn his head; his jaw should drop and his eyes should blink as well. The viewer focuses on the main action, but registers the secondary motion as

supporting it. Bryce's Advanced Motion Lab gives you enough control to manage even the finest details of your animation, so you can add this kind of secondary detail.

Exaggeration

Exaggerating an action emphasizes it, making it more prominent. For example, if intrigue is called for, have a character sneak instead of walk.

If you want your animation to resemble footage from a hand-held camera, give your camera an exaggerated bobbing motion. Virtually any type of action can be exaggerated to get an idea across.

Timing

Timing is as important in animation as it is in any dramatic form. Consider the difference between an abrupt stop and a gradual slow-down. Each conveys a completely different impression. In general, a motion that continues at the same pace lacks interest and seems unreal.

If you are trying to animate realistic character action, act out the sequence yourself, timing how long each pose is held and how long each action takes with a stopwatch.

Timing is one of the most difficult aspects of animation to master. The key events you define at different points on the time line need to be synchronized with those that came before and those that follow. Fortunately, you can use the interactive nature of computer animation to fine-tune your timing. Test your animation frequently by previewing it in the Working window or by dragging the Current Time indicator back and forth between key events. Adjust the event's position in the Advanced Motion Lab until you're satisfied with the timing.



5

Tutorial

Welcome

Welcome to the Bryce tutorial. This tutorial introduces you to all the major features and functions of Bryce. The main goal of this tutorial is to teach you the basic techniques you'll need to know to create incredible landscapes and environments.

There are two separate tutorials: a basic tutorial that shows you how to create a terrain, customize the sky, and create a body of water. The [“The Advanced Tutorial” on page 62](#) teaches you how to create a more complex environment and how to create an animation.

Each section of this tutorial is self-contained, so you can start from any point. For example, if you need to know about positioning the camera, but already know how to create skies, start the tutorial at the Camera lesson. All the files necessary for completing the lessons are provided for you on the Bryce CD-ROM. Bryce files have a BR4 file extension.

To help you follow along, every lesson contains a section called “The Story So Far,” which summarizes the procedures and techniques that have been covered in the previous lessons. A section called “What You’ll Need” tells you where to locate files that will help you complete the lesson.

Getting Started

Before you start any project in Bryce, it’s probably a good idea to become acquainted with the unique Bryce interface.

Tip

When you place the cursor over a control, the name displays in the lower left corner of the window.

The first thing you’ll want to do is configure the window to best suit how you work.

To configure the Bryce environment:

- Launch Bryce.

The Bryce window appears and fills the entire screen.

This is a great way of working as it removes all the clutter from your desktop and gives you clear access to all of Bryce’s tools.

- Click a palette, then hold the Spacebar while you drag it to a new location.

To keep the Bryce interface as uncluttered as possible, some toolbars are layered on top of each other and others are hidden when you first start the application.

To display layered palettes:

- Click the text buttons at the top of the Bryce environment. The active palette’s title appears highlighted.



The active palette’s title appears highlighted.

Some tools are hidden because you won’t need them regularly, so they appear only when you need them and then they disappear again.

To display hidden palettes:

- Move your cursor over the right edge of the Bryce window.

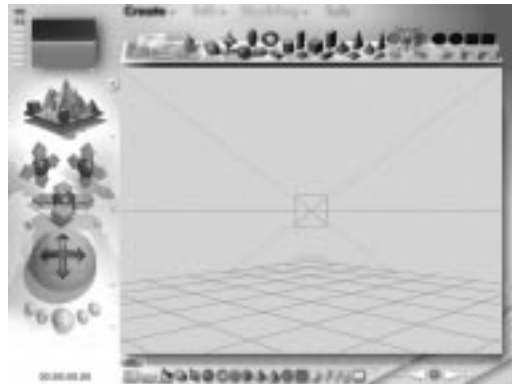

Hidden palettes appear when you pass your cursor over them, then they slowly disappear.

Along the right you’ll find the Display palette.

Most of Bryce’s tools have several options that extend their function. Whenever you see a triangle next to a tool, you know that there are more options available.

To display option menus:

- Click the triangle icon. The option menu appears.

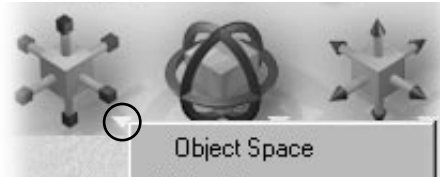

A triangle icon next to a tool indicates that there are more options available.

Now that you're familiar with how to access the tools in Bryce, you can set up a new document. Refer to "Using the Bryce Interface" on page 20 for more on using the interface.

Lesson 1: Setting Up a New Document

When you set up a new document, you're defining the size of your working space in pixels. The larger the resolution, the larger your working space. The resolution you choose depends on what type of scene you want to create.

To help you decide on a resolution, Bryce provides several presets aspect ratios for the most commonly used types of documents. Refer to "Setting Up the Working Window" on page 17 for a complete discussion of resolutions and aspect ratios.

To set up a new document:

- 1 Choose **File menu > New Document**. The Document Setup dialog appears. (If you have an existing document, you are prompted to save it.)

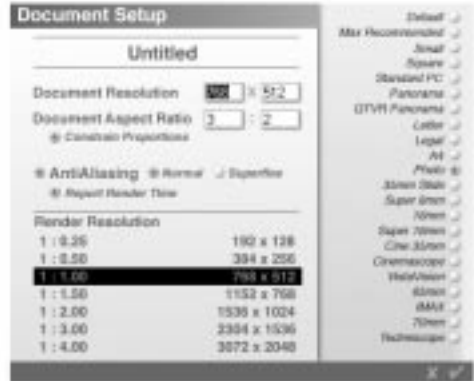

Use the Document Setup dialog to set the resolution and aspect ratio of your scene.

- 2 Click the Photo preset. The Resolution and Aspect Ratio fields update automatically.
If your monitor is set to a lower resolution, you may need to choose a different preset. Try Standard if Photo is too large for your screen.
- 3 Click the checkmark icon (also referred to as the OK icon) at the bottom of the dialog to accept your changes and exit the dialog.

Now that you have a document, you can start creating a scene. When you're working through the tutorial, it's a good idea to start with a blank scene at the beginning of each new section.

Lesson 2: Positioning the Camera

When you first create a file you'll be viewing the scene through the Director's View. In this view, you can see all the objects in the scene including the camera.

The other main view is called the Camera View, which is the view as seen through the camera. You can switch between the two views to get a different perspective on your scene.

When you're working on setting up the composition of the scene, you can use any of the Views such as Camera View or Director's View to reposition or transform objects.

To switch between views:

- Click the triangle icon beside the View Control icon and choose Director's View from the menu.
- Toggle between the views by clicking the icon (either a director's chair, or a camera).

As you work on the scene, you may find that the camera object is somewhat distracting. To avoid this, you can hide the camera in the scene.

To hide the camera:

- 1 Click the camera in the scene.

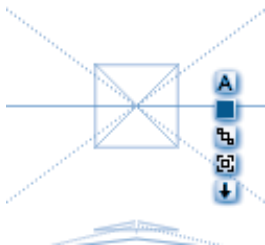

- 2 Click the A icon (Object Attributes button) that appears next to the camera's bounding box. The Camera & 2D Projection dialog appears.
- 3 Enable the Invisible option. Click the OK icon.



This option only hides the camera in the current file. It remains hidden until you show it again.

To unhide the camera:

- If you are in Camera mode, double-click the Trackball and select unhide invisible.
- If you are using the Director's View, select the camera and it automatically unhides.

In this lesson you'll use the Director's View to view and arrange objects. The controls for positioning the camera are the same, whether you're positioning the Director's View or the Camera View.

There are four controls you can use to position the camera: the Camera controls, the Trackball, the Preset Views and the 2D Project and Camera dialog. Most of these tools are located on the Control Palette.

Refer to “Setting Up the View of Your Scene” on page 328 for more on these tools.

When you reposition the camera, you’re changing the view of the scene, not the position of the objects.

To start this lesson, you’ll need to open a file with some objects in it.

To open the camera lesson file:

- 1 Choose **File menu > Open**.
- 2 On the CD-ROM, locate the file **Manual Tutorial: Camera: Camera Scene** and click **Open**.

To reposition the camera using the Camera Controls:

- 1 On the XZ control, drag the Z arrow down. The scene moves towards you. The cursor turns into an axis indicator when you move over a tip of the control.

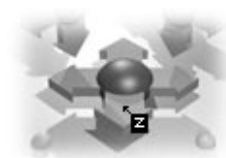

When you move over the tip of an arrow in the Camera control, the cursor turns into an axis indicator.

- 2 On the XY control, drag the tip of the Y arrow up.



Your scene should look like this when you’re done using the Camera controls.

The objects should now be easier to see, but you can adjust the camera again to get a better angle on the scene.

To reposition the camera using the Trackball:

- 1 Click the center of the Trackball and drag to the right. The scene rotates to the left.



Use the Trackball to rotate the camera around the scene.

The camera is now in an almost perfect position to view the scene. You can place the camera in a precise position by moving it numerically.

To reposition the camera numerically:

- 1 Double-click the Trackball. The Camera & 2D Projection dialog appears.
- 2 Enter Position X=24, Position Y=15, Position Z=-10, Rotate X=0, Rotate Y=-30, Z=0
- 3 Leave the remaining values at their defaults.
- 4 Click the OK icon to apply the changes to the camera.



When you apply the values you entered in the Camera & 2D Projection dialog, the view of your scene should look like this.

Now that you can see your objects, you can select and reposition them.

- 5 Close the file. Since it is a lesson, you don't need to save it unless you want to.

Arranging Objects in the Scene

The Basic Tutorial

A 3D illustration depends heavily on the arrangement of the objects in the scene to create a specific look or feel.

When arranging a scene, you should remember that you're working in 3D space, meaning that your object can be viewed from any angle. You should take all of these angles into account when you're arranging objects—an arrangement that looks good from above may not look so good from the back and so on.

The lessons in this section will help you learn how to add, position and transform objects to create a 3D illustration.

The Story So Far

Before starting this lesson, you should have your document set up and know how to access the tools and palettes in Bryce.

What You'll Need

To complete these lessons you'll need some objects to arrange. These objects have been placed in the Preset Objects Library for you. Other than that, all you'll need is a blank scene.

Adding Objects

If you have started with the default settings and see the Animation controls along the bottom of the screen, click the Selection Animation toggle at the bottom right corner of the screen to toggle to the Selection Palette. (You can also use the S key to toggle between the two modes.)



The Selection palette.

This palette allows you to select various objects in your scene prior to resizing, rotating, repositioning or applying material properties to the selected object.

At the top of the screen you'll see the words Create, Edit, and Sky & Fog. When clicked, they bring up different palettes described below.

The Create Palette

Click Create, then click any of the objects in the Create Palette to place that object in your scene.

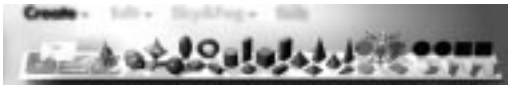

The Create palette.

Placing the mouse pointer over the different objects displays the name of the object at the bottom left of the screen. Try moving the mouse pointer over these object to familiarize yourself with them.

The Edit Palette

Click Edit to display the Edit Palette. In the Edit Palette you will be using three of the tools: Resize Rotate and Reposition.



The Edit palette.

Bryce uses three axes to Resize along, Rotate about and Reposition along. They are labelled X, Y and Z. The X axis runs from front right to back left into the scene. The Y axis runs vertically top to bottom in the scene The Z axis runs from front left to back right into the scene.

The Sky and Fog Palette

Click Sky and Fog to display the Sky and Fog Palette. The Sky and Fog Palette allows you to edit the various components of a sky preset or even to design your own.



The Sky and Fog palette.

Lesson 1: Creating Terrains

Let's begin by creating a scene which contains mountains, a sky, a ground plane and a desert lake.

To create a terrain:

- 1 Create a terrain by clicking Create to display the Create Palette, then clicking the Terrain Object in the Create Palette.

The terrain appears in your scene (This is labelled by Bryce as Terrain 1). Note the Nano Preview image shows the terrain rendered in the default colors. Your scene in Wireframe mode should look like this:

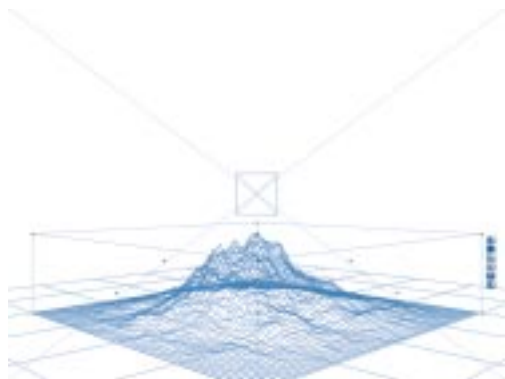

Terrain 1.

- 2 Click the Object Attributes button to display the Object Attributes box, and notice that the name of your first terrain is Terrain 1. (The Object Attributes button is at the top of the buttons associated with the selected object's bounding box.)
- 3 Click the OK icon at the bottom right of this box to exit, we will return to the Object Attributes box later on.
- 4 With the terrain selected (outlined in red) click Edit, and use the Reposition tool to move the terrain into the rear left of your scene.

As you move the mouse pointer over the arms of the Reposition tool a small tag appears telling over which axis you are positioned.
- 5 Place the cursor over the upper X (left) arm of the tool, then click the tool and drag to the left. The terrain will move along the X axis towards the rear of your scene.
- 6 Place the cursor over the upper Z (right) arm of the tool, then click and drag to the right.
- 7 Repeat this process as needed until the terrain is in the position shown below.

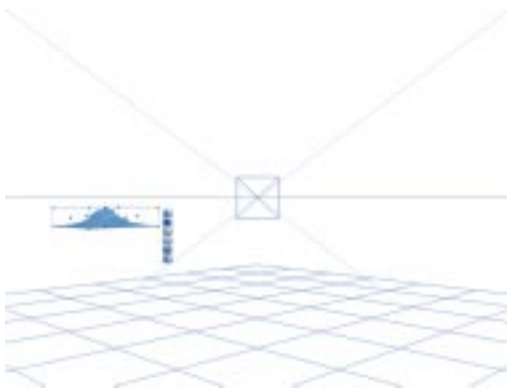

Positioning a terrain.

The terrain looks very small now so we need to resize it.

To resize the terrain:

- 1 With the terrain still selected, click the center of the Resize tool, then drag to the right to increase the size of the terrain.

Notice that as you resize the terrain it appears to disappear below the ground plane. This occurs because the terrain is resized evenly about it's center.
 - 2 Click the Land Selection button (located at the bottom of the vertical row of buttons to the right of the terrain).
- The terrain repositions on the groundplane and the arrow button disappears.
- 3 Resize the terrain until it looks something like the image below.

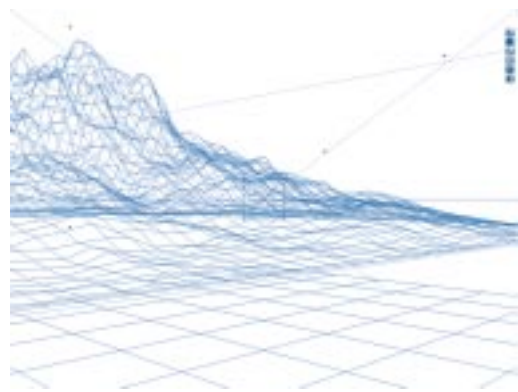

The terrain so far.

To add a second terrain:

- 1 Click Create, then click the Terrain Object to add a second terrain. Then reposition it until it is positioned and sized as shown below.

- 2 Note that this terrain (Terrain 2) is further back than the first one.



A second terrain.

- 3 Click the Render button and you should see results similar to the image below.



A rendered terrain.

To switch back to Wireframe mode:

- 1 Move the cursor just to the right of your image area and the Advanced Display Palette appears.

- 2 Near the bottom of the palette is the Display Modes button. When you place the cursor over this button, the words Display Modes appear at bottom left.

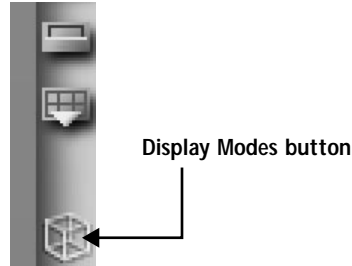

The Display Modes button.

- 3 Click this button once to return to Wireframe display mode, or click the Escape key to toggle between the modes.

Lesson 2: Adjusting the Terrain

Notice that the terrains (mountains) look a bit peaky and not very natural as a result. This can be corrected in the Terrain Editor.

To load the Terrain Editor:

- 1 Select Terrain 2 and click the Editor button (the E button located in the vertical list of buttons associated with the selected terrain object). Your screen is overlaid by the Terrain Editor.

- 2 Click the Smoothing button twice, then exit the Terrain Editor by clicking the OK icon.

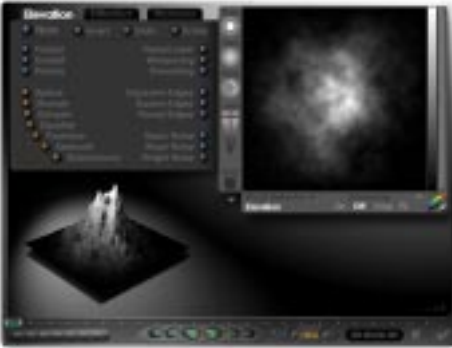

Smoothing the terrain.

- 3 Select Terrain 1 by clicking it; it becomes red.
- 4 Click the Editor button to display the Terrain Editor, then click the Smoothing button once.
- 5 Exit the Terrain Editor by clicking the OK icon, then render by clicking the Render button.
- 6 Your image should look like the one below.



Both smoothed terrains.

Lesson 3: Applying Textures

Now we will apply a material to the mountains and the ground plane. The ground plane is the grid in the foreground which appears by default whenever you start a new project. It is an infinite plane in that it extends to infinity along the X and Z axes (You'll be introduced to finite planes later in this manual).

To apply a texture:

- 1 Click the Display Modes button to return to Wireframe display mode.
- 2 Click Terrain 1 to select it.
- 3 Hold down the Shift key on your keyboard and click Terrain 2; still holding the Shift key down click the Groundplane (Plane 1). All three objects are selected and outlined in red.
- 4 Make sure the Edit Palette is showing (click Edit if needed) and click the triangle icon next to Edit.
This displays the Material Presets selection panel. On the left side and you'll see Planes and Terrains.
- 5 Click Planes and Terrains and another selection of preset materials appears.
- 6 Click Desert Rock.
A red border appears around your selected material.
- 7 Click the OK icon at the bottom right of this panel to return to your scene.
If you look at the Nano Preview window (top left) you'll see that the material has been applied.

- 8 Click the Render button and your image should look like this.



The terrains after texture has been applied.

Creating the Sky

The Story So Far

Before starting this lesson, you should know how to create a terrain.

What You'll Need

To complete these lessons you'll need an existing terrain. If you've been following this tutorial from the beginning, you can use your existing file. Otherwise, you can use the preset file provided for you. The file is called Basic Tutorial Finished Terrain and is located on the CD-ROM in the Manual Tutorials folder.

Lesson 1: Adding a Sky Preset

Now let us add a sky preset to the image.

To add a sky preset:

- 1 Click Sky and Fog, then click the triangle icon next to Sky & Fog.

A selection of sky presets appears.

- 2 Click to select Jet Stream.
- 3 Exit Sky & Fog if you want to render at this point.

You can do a render now if you like, by clicking the Render button. Let's modify the clouds to change the appearance of the scene.

- 4 Click the words Sky & Fog and to the right of the Sun Position Trackball you'll see the Sky Memory Dots, and underneath you'll see a triangle icon.

- 5 Click the triangle icon, then deselect the option Cumulus Clouds by clicking it.

The check mark should have disappeared. The original sky preset had both cumulus and stratus clouds in it and by deselecting one you changed it to a completely different sky.

- 6 Now render your scene by clicking the Render button, and you should see something like this.

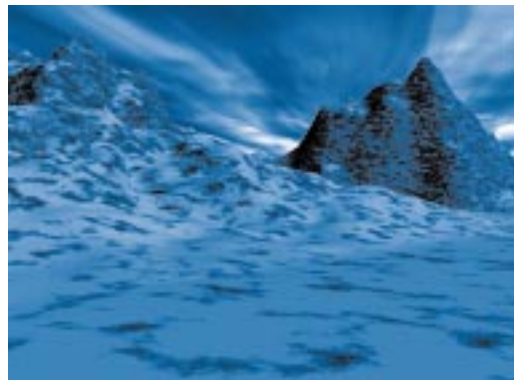

A modified sky.

Lesson 2: Adjusting the Sky

Now we'll tweak the image a bit more.

To adjust the sky:

- 1 If needed, click the words Sky & Fog to display the Sky & Fog Palette.
Move the mouse pointer over the thumbnail pictures across the top of the screen and note the wording that appears in the bottom left. Locate the one called Haze.
- 2 Click the Haze thumbnail picture, then you'll see the figure 1 appear at the bottom left, this is the Haze value.
- 3 Drag the Haze value to the right and this figure will increase. Increase the haze value to 17.
Note that dragging to the left will reduce the value.
- 4 Render your scene again and notice how the increased haze value has separated the two mountains appearing to push the farther terrain further back in the distance.
You should now see something like this.



A hazy sky.

Creating a Body of Water

The Story So Far

Before starting this lesson, you should have an existing terrain. The previous lessons taught you how to create a terrain and customize a sky preset.

What You'll Need

To complete these lessons you'll need an existing terrain. If you've been following the tutorial from the beginning, you'll have an existing file. Otherwise, you can load the preset file Basic Tutorial Finished Sky provided for you.

Lesson 1: Preparing the Landscape

The area in the foreground needs some interest added—how about a body of water such as a lake. What we'll do is “dig” a hole in the ground and add some water. This requires the use of a boolean operation, you will learn about these in detail later in the manual.

In this tutorial, we'll use a Negative boolean operation to cut out a hole in the ground plane. A Negative boolean operation requires a Positive object (or a Positive group of objects) and a Negative object. When these are grouped together the shape of the Negative object is cut out of the Positive object. Objects can be given Negative or Positive attributes in the Object Attributes box.

To set the landscape as a positive boolean object:

- 1 Click the Selection Animation toggle (in the lower right corner) to switch to Wireframe mode.

- 2 In Wireframe mode select one of the terrains.
- 3 Then while holding the Shift key down select the second terrain and the ground plane.
All three should now be highlighted in red.
- 4 Click the Object Attributes button (A button) to display the Objects Attributes box, then click Positive. This sets each one of the selected objects to Positive.
- 5 Exit the Object Attributes box by clicking the OK icon.

To group the terrains:

- 1 Click the Group button (the G button in the vertical list associated with the selected objects) to group the three objects Terrain 1, Terrain 2 and Plane 1 together in a Group called Group 1.
- 2 With Group 1 still selected, click the Objects Attributes button, then set Group 1 to be Positive.
- 3 Exit the Object Attributes box by clicking the OK icon.

Lesson 2: Creating the Interior of the Lake

Next create a third terrain—Terrain 3 and apply the same Desert Rock material as you used before. Refer to “Lesson 1: Creating Terrains” on page 53 to create the terrain and “Lesson 3: Applying Textures” on page 56 to apply the texture.

This terrain needs to be rotated through 180 degrees about the X or Z axis, to create the interior of the lake.

To rotate an object:

- 1 Click Edit, then the Rotation control. Move the mouse pointer over the X or Z axis rotation ring.
- 2 Hold down the Shift key (this causes the rotation to be carried out in 45 degree increments), then click and drag horizontally on the rotation ring.
You’ll see the angle of rotation displayed at the bottom left of your screen.
- 3 Drag until you see either 180 or -180. The terrain will now be upside down and your screen should look like this.

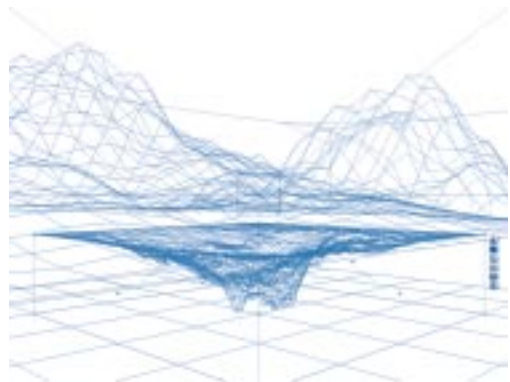

An inverted terrain.

- 4 With Terrain 3 still selected, click on the Object Attributes button to display the Object Attributes box, then click Negative. It is now a negative boolean object. This means that Bryce will “cut” this shape from the terrain.
- 5 Exit by clicking the OK icon.
You’ll notice that the Terrain 3 wireframe is dotted since it is now Negative.

- 6 Lower Terrain 3 until the square base (which is now on top) is just above the ground plane.
- 7 Click Edit and use the Reposition tool to position it along the Y axis.
- 8 Your screen should look like this.



Positioning the inverted terrain.

To group the terrains:

- 1 With Terrain 3 still selected, hold down the Shift key and click one of the other terrains to select Group 1 together with Terrain 3.
- 2 Click the Group button.

- 3 When you render now by clicking the Render button, you will see a hole has appeared in the ground plane.



A hole in the ground plane.

It looks a little on the small side for a lake though, more a pothole. Let's make it bigger.

- 4 Return to Wireframe mode by clicking the Selection Animation toggle found in the lower right corner of the Bryce window, then click the Terrain icon in the Selection Palette at the bottom of the screen. Keep the mouse button depressed.
- 5 You'll see Terrain1, Terrain 2 and Terrain 3 listed—select Terrain 3.
- 6 With Terrain 3 selected, use the Resize tool to make it bigger and the Reposition tool to fine tune the positioning.

Terrain 3 should now be the only selected object. Although it is part of a group this terrain can still be repositioned, resized and rotated singly.

Watch the Nano Preview to check the effect you're creating. When you lower the terrain, keep the square bottom above the ground plane otherwise the hole will disappear.

- 7 When you've adjusted the size and position of the hole you should see something like this after rendering.



An enlarged hole in the ground plane.

Lesson 3: Filling the Lake

Now we'll fill the hole with water.

To fill the lake:

- 1 Click Create to display the Create Palette.
- 2 Click the Water Plane icon.
A water plane appears with a random water material applied. It covers the whole of your image up to the bases of the mountains—this is another of those infinite planes.
- 3 Click Edit to display the Edit Palette, then click the triangle icon next to the word Edit.
This displays the Materials selection panel.
- 4 Select Waters & Liquids then choose Waves of Reflection (third row down, three from left).
- 5 Click the OK icon to exit the Materials selection panel.

- 6 With the water plane still selected use the Reposition tool to lower the plane along the Y axis until it is just below the ground plane.

- 7 Now render and you will see results that look like this.



A filled lake.

This concludes this beginners tutorial and shows how a basic landscape scene is constructed in Bryce. This tutorial has only touched on a very small fraction of the controls and procedures available in Bryce. You could go further with this image by adding some rocks to the foreground, perhaps some vegetation all by following the basic Create, Size, Rotate, Position and Apply Material.

Try different water materials for the water plane and different terrain and plane textures. A different sky perhaps—in Bryce the variations are literally endless.

The Advanced Tutorial

Part 1: Creating and Importing Objects

In the first part of this tutorial, you will create an interior scene of a building with vaulted ceiling. The centerpiece of this room is a mirrored sphere that you'll import. Then, you'll place lights to light your scene. In the next part, you'll animate the camera to fly through the scene.

The Story So Far

Before starting this lesson, you should know how to use Bryce's tools to create and adjust objects, and how to position and move the camera. Refer to the previous sections of this tutorial for review if needed.

Launch Bryce, and choose **File menu > New Document**. Set the file to the size of 480x360.

What You'll Need

To complete these lessons you'll create most of the objects you'll need to use.

Creating the Interior Scene

In this series of lessons, you will construct a building out of Bryce primitives. You'll use Bryce's edit controls to change their size, position and rotation as needed to make the building. You'll also use booleans to carve one piece out of another. Then, you will work with basic scene organization using Bryce's Family controls.

Next, you will add an object of interest to your building by placing a sphere on a pedestal. Then you will light the interior of your scene.

In Part 2 of the tutorial, you will animate the camera to fly through the building and create an animation. You'll work with pre-production animated-scene planning, planning your animation timeline, setting keyframes, and animating your camera. You'll also learn some steps to tweak your camera path.

Creating the Roof

Lesson 1: Creating a Vaulted Ceiling

This building is fairly easy to create. While creating it, you will become familiar with the create and edit controls of Bryce, as well as review the use of booleans.

Notice that the order used to create objects in Bryce, doesn't match how those objects would be created in the real world. In this example, the roof is created first, and later the walls are added underneath.

To create the roof of the vaulted ceiling:

- 1 Click Create to switch to the Create Palette.

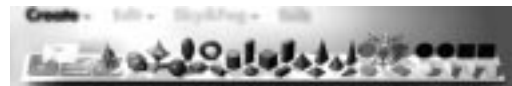

The Create palette.

- 2 Click the Create Pyramid icon.

A pyramid appears in your scene.

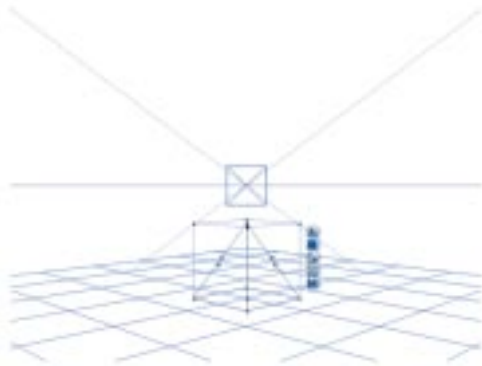

A pyramid displays.

Next, adjust the pyramid's size so that it is flatter overall by reducing its height.

- 3 Click Edit to switch to the Edit Palette. The Edit Palette appears.

Move the cursor over the top of the Resize tool. The cursor changes to a Y and the tool changes to enlarge toward the top.



The Edit palette.

Click the top of the Resize tool and hold down the Shift key. (This makes the object change size by regular increments.) Slowly drag to the left. The pyramid will snap to half its previous height.

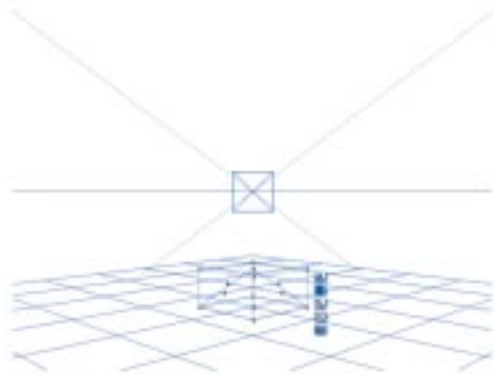

The pyramid before the height change.

Next you'll proportionately enlarge the pyramid. This time, work directly with the object's handles in the scene window.

- 4 Place the cursor over the upper right corner of the object's bounding box, next to the Object Attributes button (the A button). The cursor changes to a proportional resize.

Click there and hold down the Shift key, then drag to the right. The pyramid snaps to larger sizes. Drag for one snap, then release the mouse. Next, drag for three more snaps.

The pyramid is enlarged, and should extend off the right edge of the scene window.

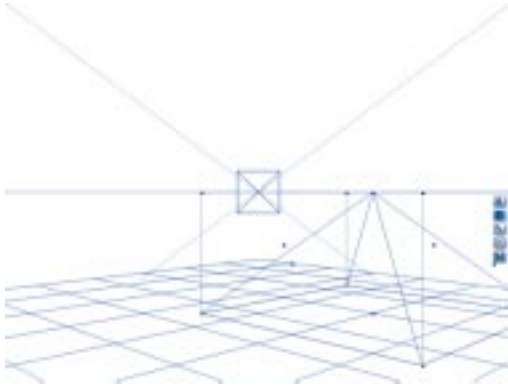

The enlarged pyramid.

Next, you'll use the arrow keys to nudge its position to a more central place in the scene.

- 5 Press the left arrow key four times. The pyramid moves so that the entire object can be seen in the scene window.

Lesson 2: Converting a Pyramid

The next task is to duplicate the pyramid and convert it to a sphere. Eventually the sphere will be "cut out" from the pyramid using a boolean operation.

To duplicate the pyramid:

- 1 Choose **Edit menu > Duplicate**. A second pyramid appears in the exact place where the first one is.

Click the double arrows at the top right of the Edit Palette. A set of Bryce pyramids appears. Drag to the left until the sphere primitive is highlighted.



The highlighted sphere primitive.

Release the mouse. The pyramid has changed to a sphere.

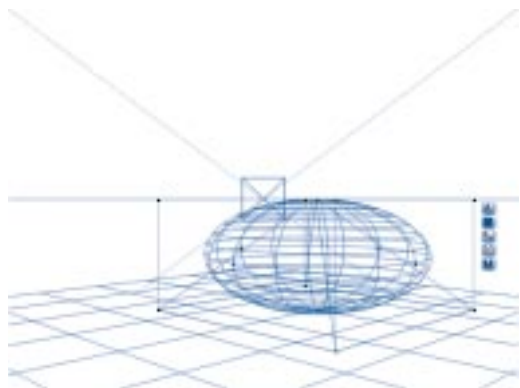

The converted pyramid.

Lesson 3: Resize the Sphere

To cut the sphere out of the pyramid, its size needs to be changed, and its position adjusted slightly. This time you will resize the object using another one of Bryce's edit controls: the 3D Transformation dialog box.

To resize the sphere:

- 1 Click the triangle next to the Resize tool, then select 3D Transformations from the list. A dialog box appears.

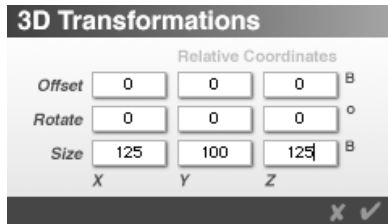

3D Transformations dialog.

The bottom row of options are for changing the object's size. Size is expressed as a percentage of the current size. To enlarge the sphere horizontally without affecting the height, you will enter new values for the X (width) and Z (depth) axes and leave the height (Y) axis unchanged.

- 2 In the numerical boxes for size for the X and Z axes, enter 125 (for 125%). Click the OK icon to exit the dialog box. The sphere expands slightly on the horizontal axis while remaining unchanged in height.

Next, adjust the position of the sphere so that it cuts out portions of the pyramid, leaving the four corners intact as a roof support. To more easily see what you are doing, change your view of the scene to front.

- 3 On the Controls Palette, choose **View Controls menu > Select From Front**. The scene changes so that you are viewing the objects from a straight horizontal view.



The View options From Front.

In the next step, you will move the sphere down.

- 4 Place the cursor over the top of the Reposition tool on the Edit palette. The cursor changes to a Y. Hold the Shift key, click, then drag to the left. The sphere drops so that it is half hidden under ground. Release the mouse.

Next you will lower the sphere a bit more (without using a key constraint) until the next “rung” of the wireframe is aligned with the ground level.

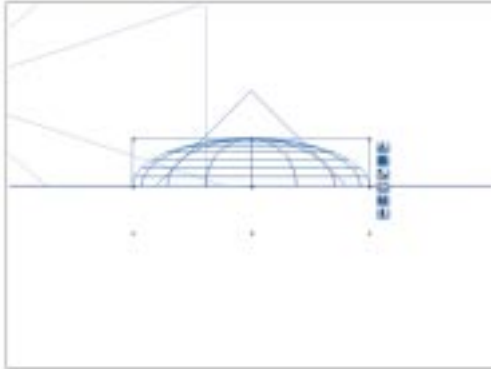

Lowering the sphere.

- 5 Click the top of the Reposition tool again, then hold the Shift key and drag to the left slightly until the wireframe is aligned with the ground. You may have to do it two or more times to get the alignment exact. The sphere should now look like the one shown below.

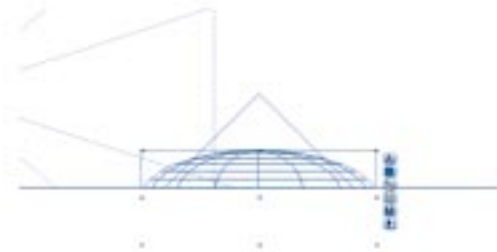

The converted pyramid

If your scene doesn't look like the one shown, select the pyramid, and zoom in twice by clicking the Zoom in button located on the lower section of the Display palette (to the right of the Working Window).

Lesson 4: Cut Out the Roof with the Sphere

The next task is to carve out the under side of the roof with the sphere by using a boolean operation. For this, change back to the Director's View.

To cut out the roof:

- 1 Click the triangle next to the View control, then choose **View Options menu > Director's View** from the Control palette. The view icon changes to a Director's chair, and your scene changes to the perspective you had when you started this tutorial.

Now, assign boolean properties to your objects. The sphere is selected, so we'll start with that.

- 2 Click the Object Attributes button next to the sphere's bounding box. The Object Attributes dialog box appears.

Under the title, Sphere 1, the button for Neutral is selected. That is the default for all Brycean objects.

- Click the button next to Negative. Click the OK icon to exit the Object Attributes dialog box. The sphere's wireframe changes to dotted lines.

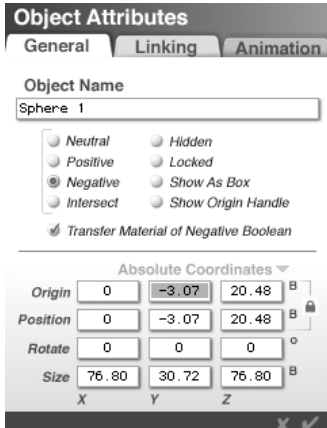

Setting an object to negative.

Next, make the pyramid positive.

- Select the Pyramid by clicking it. Its wireframe turns red.

You could use the Object Attributes dialog box to make the pyramid positive. However, Bryce has an easier way.

Simply type P (for positive). The wireframe doesn't change; its line is still solid. You can check the Object Attributes dialog box to confirm that the change occurred if you want.

Tip To make an object negative, type N. To make it intersect, type I. To make it neutral, type the letter O.

Lesson 5: Creating a Group

To make the boolean effect work, you must group the objects together. The pyramid is already selected. Add the sphere to your selection.

If the Selection palette isn't displayed, click the Selection Animation toggle, or type S, to switch palettes.

To group objects:

- Press the Shift key, which allows you to add to the selection. Then, on the Selection Palette (below the Working Window), click the Select Sphere icon. The sphere's wireframe is red as well as the pyramid's.

If the Animation palette is displayed, click the Selection Animation toggle at the bottom right corner to toggle to the Selection palette, or type S.

- Group the objects by clicking the Group button located next to the selected object's bounding box.

The bounding box changes slightly, with diagonal insets at each corner. This indicates that the object is a boolean group. In addition, the G button disappeared, and a U button took its place. (The U stands for Ungroup.)

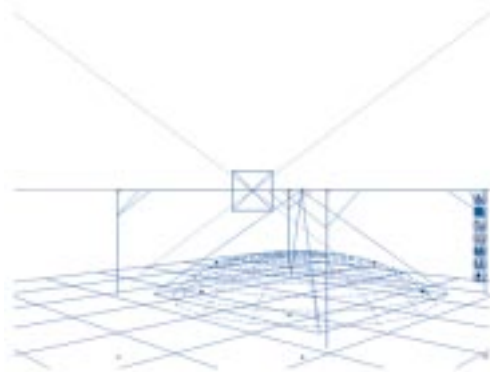

Setting an object to negative.

- 3 Render the scene to check your handiwork, by clicking the Render button. Your scene should look like the scene shown below.



The results so far.

Creating a Family Group

You have now constructed the ceiling of this building. Before moving on, however, a bit of housekeeping is in order. Since you will be adding new objects to your scene, now is a good time to name this group and assign it a unique family name and wireframe color.

To create a family group:

- 1 Press the Esc key to switch back to wireframe mode. The wireframe of your scene appears.
- 2 Click the gray Family button underneath the Object Attributes button. The Family dialog box appears. The gray color is selected and the Default Family name displays at the bottom of the dialog box.

- 3 Click the bottom left color (maroon). The text display now reads Family 21. Type the words Boolean Roof. The text changes.

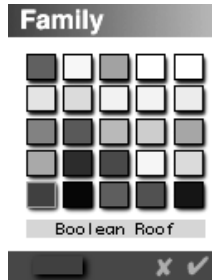

The Family dialog box.

- 4 Click the OK icon to exit the Family dialog box. The dialog box disappears, and the Family button has changed to the maroon color.
- 5 Deselect the object by clicking the background of the image. The wireframe has now changed to maroon instead of gray. The family name and color now displays under the families menu. You can check this out.
- 6 Locate the Select Families icon on the Selection Palette. Click the icon and a menu appears. Notice that one of the items there is the family you just created, Boolean Roof. Select that item on the menu. Your group, the boolean roof is selected again. (Note: the other family besides the Default Family, Family 17, is the family color for the camera which is always present in your scene.)



The Select Families menu.

- 7 Save your scene file and give it the name Rendered Boolean.

A copy of the scene file at this stage is located on the Bryce 4 CD-ROM in the Manual Tutorial folder. It is called Rendered Boolean.

Building the Walls

In this next section, you will create walls for your roof using the cube primitive. Before doing so, however, you will need to move the roof up so that the walls can fit underneath.

What You'll Need

If you are continuing from the previous step, ensure that your scene file from the previous section is open. If you are beginning this tutorial from this point, open up the scene file called Rendered Boolean, located in the Manual Tutorials folder on the Bryce 4 CD-ROM.

Lesson 1: Moving the Roof

To move the roof up:

- 1 If needed, select the Group by clicking it in the scene window. The wireframe turns red.
- 2 Press the Page Up key 6 times to move the object up. The bottom of the pyramid is aligned to the horizon.

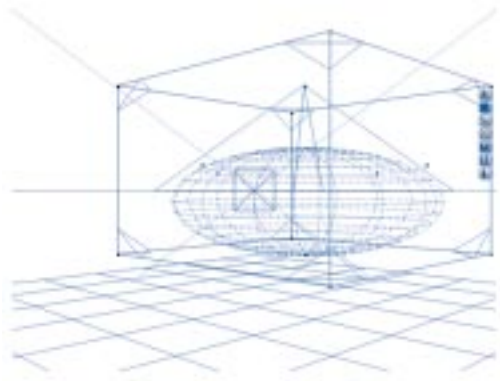

Moving the roof.

Note

If you do not have a keyboard with a page up key, here is an alternative way to move the group up.

- 3 Click the Object Attributes button to access the Object Attributes dialog box. Change the settings for Position on the Y axis to 36.86.

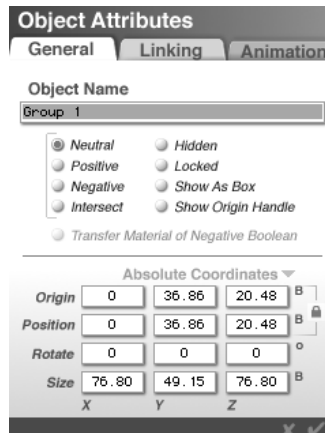

The Object Attributes dialog box.

Lesson 2: Creating the Walls

You are now ready to create walls to go underneath your ceiling with the arched cutouts. The Cube primitive will be the basis of your walls.

To create walls:

- 1 On the Create Palette, click the Create Cube icon. A cube appears in your scene.
With so many objects in the scene, assign this cube to its own family right away.
- 2 While the newly created cube is still selected, click the family color button to access the Family dialog box. Change its color to an unused color and type the word Wall in the text entry field. The family color is changed.

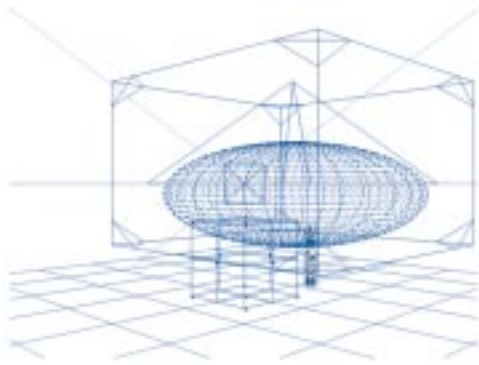

Creating the walls.

- 3 Look at your scene from Top View by choosing the Control Palette, **View Options menu > From Top**. The scene changes to top view.

Tip

Another way to see your scene from top view is to use a keyboard shortcut. Press the number 2. (` or ~ is Director's View, 1 is Camera View, 2 is Top View, 3 is From Right, 4 is From Front)

You can zoom in on your view to make the wireframes bigger.

- 4 Click the Zoom In tool on the Advanced Display palette (the Zoom In tool is the magnifying glass with a +). The Advanced Display palette is a hidden palette located to the right of the Working Window. Move the cursor over it to display it.

The view grows larger, with the selected cube object in the center of your scene window.

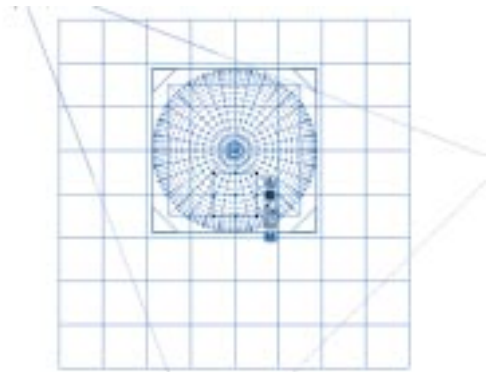

View from the top.

Lesson 3: Adjusting the Wall Size

Notice that the cube's bottom edge is aligned with the pyramid's edge. The group's edge extends beyond that, due to the size of the sphere, but the edge that you want to work with is the pyramid. So the cube is aligned on the outside edge. However, it needs to be made wider to match the pyramid's width, and narrower in depth so that it does not occupy so much of the pyramid's interior. We'll start with this size change.

To adjust the wall size:

- 1 Place the cursor over the top center point of the bounding box. The cursor changes to a Z, indicating that Bryce is ready to work with the object along the Z axis. Click there, and hold down the Shift key, then slowly drag to the left. The cube snaps to half its depth. Release the mouse. Repeat this step, to shrink it to half its depth again.

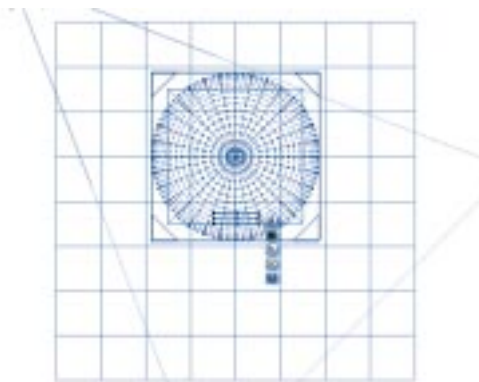

Adjusting the wall size.

The wall is thin enough; now it's time to make it wider.

- 2 Place the cursor over the right center point of the bounding box. The cursor changes to an X. Press the Option or Alt key (this

will resize the object from the center). Press Shift and click, then slowly drag to the right. The cube widens by set increments. By the fourth snap, it matches the width of the pyramid. Release the mouse and keys.

If needed, nudge it into position so that it aligns correctly.

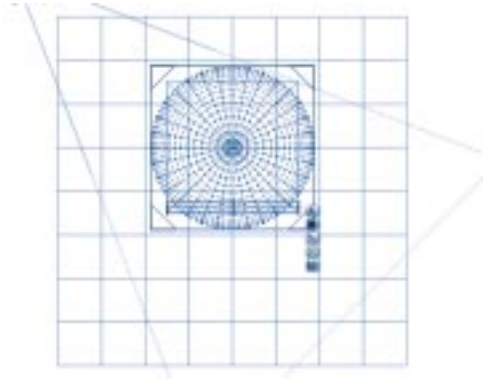

Widening the wall.

Lesson 4: Duplicate the Walls

You now have one wall. Duplicate this wall to create the one opposite.

To duplicate the walls:

- 1 Duplicate the cube by choosing **Edit menu > Duplicate** or by pressing Command/Ctrl+D. A second cube appears in the same place; it shares the size characteristics of the first.
- 2 Press the up arrow key to move the wall to the opposite side. (11 to 13 taps should place it there.) The second wall is now located at the opposite end.

The wall could be duplicated, rotated 90 degrees and nudged into position with the arrow keys, and then duplicated again and nudged to the opposite end. There is an easier way, however.

- 3 Click the Select Families icon on the Selection palette, and select Wall from the list. Both walls are selected.
- 4 Duplicate these walls by choosing **Edit menu > Duplicate** or by pressing Command/Ctrl+D. A second set of walls is created in your scene.

For the next action you will temporarily group the newly created second set of walls.

- 5 Click the Group button to group the walls. The G button changes to a U, indicating that the objects are grouped. The Family button color is gray for Default family (as a new entity, it takes on the Default Family color and label.)

Now you can rotate this group around its center, which happens to be the same as the center of the pyramid room.

- 6 Click the Edit button to bring up the Edit Palette. Place your cursor over the horizontal band of the Rotate tool. The cursor changes to a Y.



The Rotate tool.

- 7 Press the Shift key to constrain rotation to 45 degree increments. Click and slowly drag in either direction. The group snaps first to 45 degrees, and, as you continue dragging, to 90 degrees. Release the mouse.

- 8 Ungroup the group by clicking the Ungroup button. The U changes to a G, and the Family color changes to the Wall color.

Lesson 5: Make the Walls Taller

Before starting this lesson, switch back to Director's View.

To make the walls taller:

- 1 On the Controls Palette, select **Control Options > Director's View**. The view changes to show more depth perspective.
- 2 Click the Render button to render your scene. It should look like the image shown.



The rendered scene at this point.

The walls are there, but they're not tall enough.

- 3 Press the Escape key. The wireframe view of your scene appears.
- 4 Make sure the Wall is selected, then place the cursor over the top part of the Resize tool. The cursor changes to a Y.

- 5 Press the Shift key, then click and drag to the right until the walls pop up to meet the bottom of the pyramid and align themselves with the horizon.

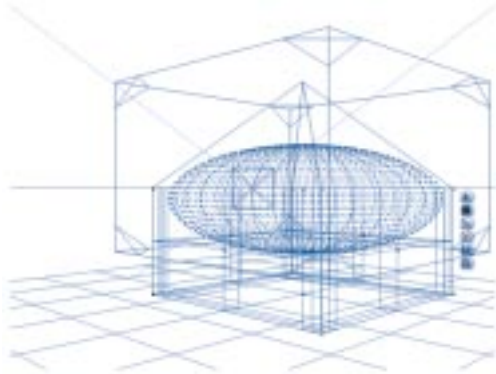

Raising the walls.

You now have created a building with a pyramid roof, arched cutouts to let light inside, and walls all around. Congratulations! All you lack is a door. (It's always something, isn't it?)

Lesson 6: Adding a Doorway

To add the doorway, look at the scene from top view.

To add a door:

- 1 Look at your scene from top view by choosing **View Options menu > From Top**, or press the number 2).
The walls objects should still be selected. The boolean roof wireframe will be a hindrance. You'll hide it using Solo Mode, so you can concentrate only on your wall objects.

- 2 On the Selection palette, click the Solo Mode button. All unselected objects (the ground plane and the boolean group) disappear, leaving only your selected objects and the camera.

Make the boolean doorway by duplicating and resizing one of the cubes so that it cuts a hole through the wall. We'll put the doorway in the front wall.

- 3 Deselect the wall objects by clicking elsewhere in your scene window. Click the bottom cube object to select only it.
- 4 Duplicate the object by choosing **Edit menu > Duplicate**, or Command/Ctrl-D). This new object will become the doorway object.

The doorway object needs to be made a little thicker than the wall it will be subtracting from. While you're still in Top View, you will increase its depth slightly.

- 5 Click the Z axis on the Resize tool. Hold down the Option (Macintosh) or Alt (Windows) key to change the size symmetrically. Drag a tiny bit to the right on the Resize tool to make the doorway object thicker. It doesn't have to be much. The object is a little thicker than the front wall.

The other resize adjustment need to be made looking at the object from Front View.

- 6 Switch to Front View by choosing **View Objects menu > From Front** or press the 4 key. The view of the scene changes to front view.

- Click the X axis on the Resize tool. Hold down the Option/Alt key and drag to the left until the object is about the width shown.

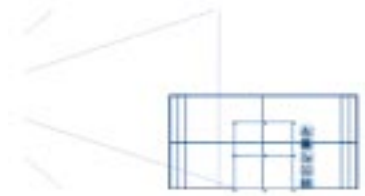

Creating the door.

- Locate the top Y axis on the Resize tool. Drag left to shorten the doorway until it looks to be about the height shown in the figure above.

Lesson 7: Assigning Boolean Properties

After the doorway object is created and sized correctly, assign boolean properties to it. The doorway needs to be cut out of the wall, so you'll need to make the doorway object negative.

To add boolean properties:

- Press the N key to make the doorway object negative. The wireframe changes to a dotted line.
- Select the front wall by clicking it. The wireframe turns red.

Since you can't tell from looking at the scene from front view whether the front wall or the back wall is selected, it's a good idea to look at your scene from top view.

- Switch to Top View by choosing **View Options menu > From Top**, or press the 2 key). Your scene changes to top view. The front wall should be selected (and the back wall should not.).
- Change this object's properties to positive. Press the P key or click the Object Attributes button to access the Object Attributes dialog box, then click the button next to Positive. The wireframe remains solid.
- Select both the front wall and the doorway by drawing a selection marquee around their centerpoints, as shown. The wireframes of both objects are red.

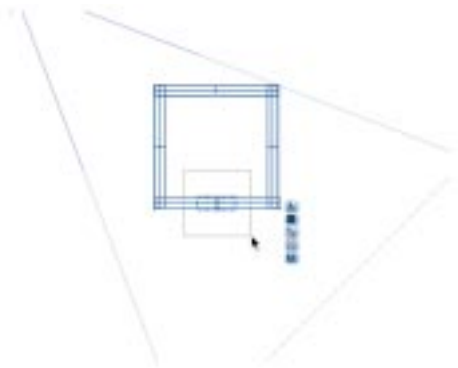

Creating a boolean object.

- Click the Group button to group them. The G changes to a U and the family color changes to Default Gray. Since this group is part of the Wall family of objects, it's a good idea to assign the group to the Wall family.

- 7 Click the Family button on the Selection palette to access the Family dialog box. Select the family for wall. Click the OK icon to exit the dialog box. The Family button changes to the Wall wireframe color.
Congratulations! You just carved a boolean doorway out of a wall. It's time to leave Solo Mode and see the results in the main scene.
- 8 Click the Solo Mode button to exit solo mode. The rest of your scene appears.
- 9 Change to Director's View. by choosing **View Options menu > Director's View** or type the ` key). Your scene appears in perspective.
- 10 Click the Render button.
You may need to adjust the walls if there is a gap between the walls and the roof.
- 11 Save your scene.

Group and Grow the Entire Building.

You'll be placing objects inside this building and eventually flying through it with the camera, so the building needs to be bigger than it is currently. When you enlarge the entire object as a group, the individual objects retain their size and position relationship to one another.

Lesson 1: Grouping the Building

To group the building:

- 1 Choose **Edit menu > Select All** (or command/Ctrl+A). All of your objects, including the ground, are selected.

- 2 Hold down the Shift key and click the ground to deselect it. The selection bounding box encloses only the pyramid group and the wall objects. The Group button is showing.
- 3 Click the Group button to group these objects. The G disappears.

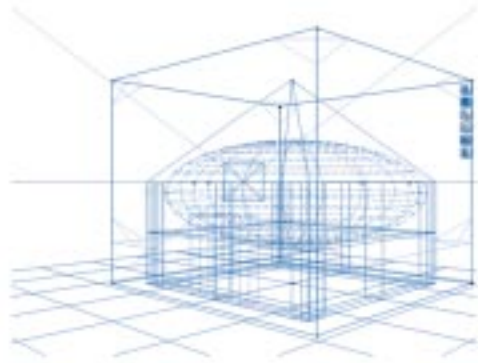

Grouping the building.

- 4 Press the * key two times (Shift+8). Each time, your group's size doubles. So it is now four times what it was when you started. There is also an up arrow button at the bottom of the group of buttons associated with the selected object.

The upward pointing arrow indicates that a portion of your grouped building is underground. In this case, when you doubled its size, it enlarged from its center, so a good portion of the building is underground.

- Click the upward pointing arrow button (located with the group of buttons associated with the bounding box of the selected object). The group jumps up so that it is now resting at ground level.

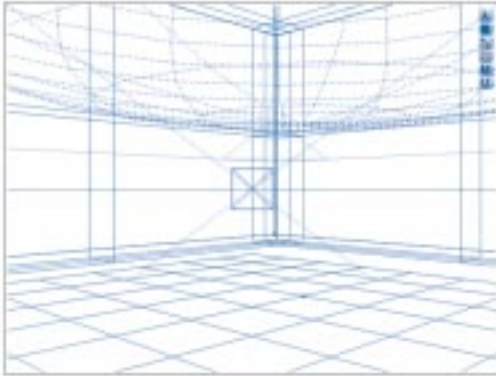

Grouping and positioning the building.

Lesson 2: Change Your Perspective of the Scene

You need to adjust your perspective of the scene so you can see the entire building. In fact, if you were to render right now, you'd see nothing, because the perspective is from within one of the walls.

To change perspective:

- Place the cursor over the Trackball control on the Controls palette. The cursor changes to double crossed arrows while the TrackBall changes colors.
- Click and drag the Trackball to the right. The scene rotates counter clockwise in the scene window. Keep dragging until the blue camera wireframe is on the left side of the window and the center wireframe lines

of the front and back walls line up in the center of the window, looking like the scene shown.

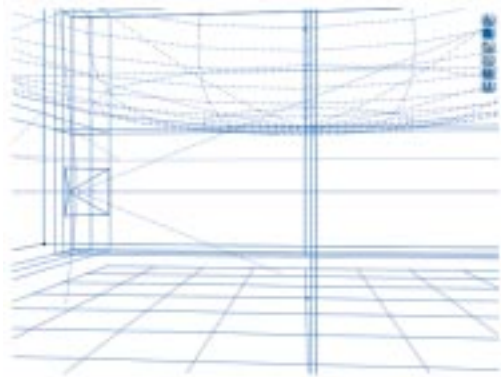

Changing perspective.

- Click the Render button. You'll see a diagonal streak of light running from the upper right to the lower left in your scene as the scene renders.

You are now looking through the doorway of the building, but are very close. So how about moving back?

- Place the cursor to the closest arrow of the XZ Camera Cross, located just above the TrackBall control on the Control Palette. The cross changes color and the cursor changes to a Z.

(If the cursor is a crosshair or an X, it's because the cursor is located over a different part of the XZ Camera Cross control. Move it around until the cursor changes to a Z.)

- Drag up on the XZ Camera Cross until you can see the entire front wall of the building. You may have to move the camera a couple of times until it reaches that point.

The scene should look like what's shown here.

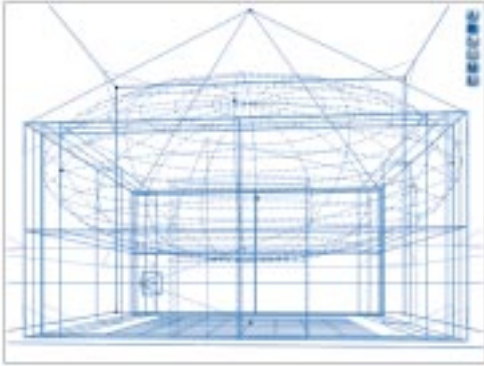

Changing your viewpoint.

To see the entire building, we have to move things down. There are two possibilities: one is to use the camera controls to move the Director's View higher. That will move the building down. But it will also look at the scene from a higher perspective.

The other alternative is to pan the scene down with the Pan tool. It will not change the perspective of the scene, merely show more of what's higher.

- 6 For this lesson, use the camera controls.
- 7 Render the scene.
- 8 Save your scene and call it Grouped Building.

Sphere on a Pedestal

The next step of this tutorial will have you work with an already existing scene file and merge it into the one you are creating.

The Story So Far

If you are continuing the tutorial, you should have created a building with a roof, walls, doorway, and are ready to add the centerpiece.

What You'll Need

If you are starting at this point, open the file called Grouped Building, and you'll soon merge the file called Pedestal Merger. Both files are located on the CD-ROM in the Manual Tutorials folder.

Lesson 1: Merging an Existing Scene

To merge another scene:

- 1 Select **File menu > Merge**. An Open dialog box appears.
Use it to find the scene file you want to merge into your current scene.
- 2 Navigate to the Manual Tutorial folder on the Bryce 4 CD-ROM. Select the scene file called Pedestal Merger and click the Open button. The Wireframe for the merged scene appears in your scene, and is selected.

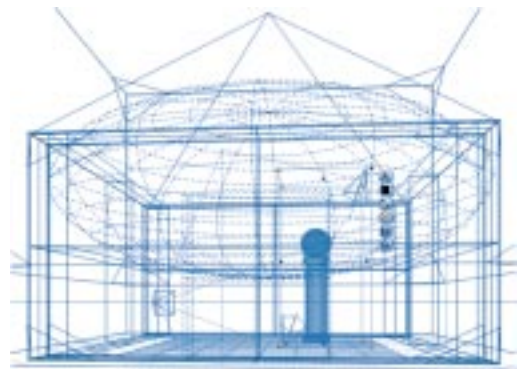

The merged scene.

- 3 Render the scene. There is now a pedestal with a mirrored sphere on it. There are lights in the scene as well.



The rendered scene.

Lesson 2: Adjusting Lights

The merged objects should still be selected. In this next section, you will make slight modifications to the lights and use Bryce's tracking controls to make the lights always point at certain objects. To make it easier, you'll need to temporarily rid your scene of extraneous objects.

To adjust lights:

- 1 Click the Solo Mode button on the Selection palette to change to Solo mode. The ground, walls and building objects disappear, leaving only the two lights and the pedestal and sphere.

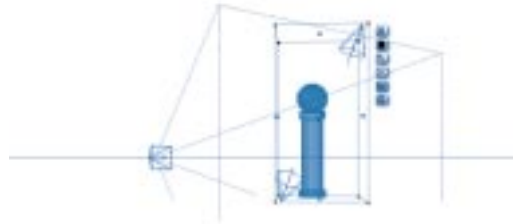

The scene in Solo mode.

- 2 Click away from the objects to deselect them, then select the lower light. The fourth button down (in the group of buttons associated with the selected object) is the Tracking icon.
- 3 Click the Tracking icon and drag from it to the sphere object. While your mouse button is still pressed, whatever object is underneath the mouse turns blue. When the sphere turns blue, release the mouse. The light is now set to track the sphere.
- 4 Drag the light so that it is located above and to the left of the sphere. The light remains pointing at the sphere.
- 5 Click the Land Selection button (the Down arrow button located in the group of buttons associated with the selected object). The light snaps to the ground, pointing toward the sphere from this position.
- 6 Select the light that is located above and to the right of the pedestal. The wireframe turns red.
- 7 Drag from this light's Tracking icon to the tall cylinder. The tall cylinder turns blue. Release the mouse.

- 8 Drag the light down and to the right slightly.

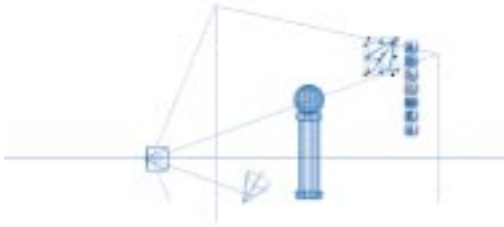

Repositioning a light.

- 9 Click the Solo Mode button to exit Solo Mode. The rest of your scene appears.
- 10 Render and save your scene.

In the next tutorial, you'll animate your camera to fly through the scene.

Part 2: Animate the Scene:

In this second part of the building tutorial, we will animate the camera to fly through this scene. You may start with the scene file you were working with before, or you may use the scene file entitled Animation-start.

What You'll Need

A stopwatch, watch, or clock with a sweep second hand. (Or you can count very slowly.)

Pre-Production

In this tutorial, you will go through the process of thinking through the creation of an animation where you fly the camera through this scene.

You'll work on some pre-production tasks prior to animation. Then you will animate the camera, and tweak and finesse the animation, and conduct test renders.

Lesson 1: Pre Visualizing and Timing the Sequence

Let's take a moment and think about where the camera should go. The pre-production and storyboard phase is one where you think through what you want to accomplish for the animation. We'll take a modified storyboard approach where we'll think through the camera path.

Up until now, however, you've been working with your scene in Director's View and in the different orthogonal views. For scene creation, Director's View is better. For animating you will use Camera View. Let's start by locating the camera where the Director's View is.

To plan and time the sequence:

- 1 On the Controls Palette, choose **Camera Options menu > Camera >> Director**. The camera wireframe disappears from the scene.

The camera object has moved to the same location as the Director's View, so it is now located at your point of view.

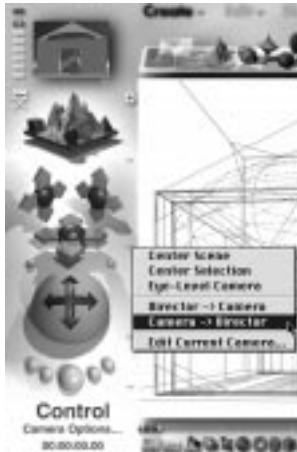

Camera Options.

When you view your scene from above you will see the camera's wireframe location has changed.

- 2 View your scene from Top View. On the Controls Palette, choose **View Options menu > From Top**, or press the 2 key. Your scene changes to top view. The camera is now located at the bottom of the scene window.

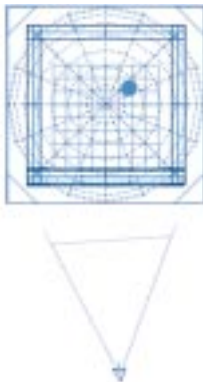

The top view

In this animation, the path the camera will take goes through the doorway, circles around the pedestal, then goes out through the archway just above the left wall. Note that you might have to zoom out to see the same view as this image.

- 3 On the Display palette, (to the right of the Working Window) click the Demo marker tool. Beginning at the camera's location, drag the mouse to draw a path from the camera, through the doors, around the pedestal, and out the left side. Your screen should look something like this:

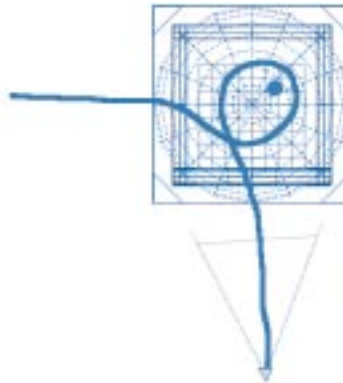

Drawing the path.

Look at the path there. How long should this animation last?

Get your stopwatch, watch, or clock with a sweep second hand. Or, start counting very slowly. Envision what the camera does while timing the sequence. You may narrate the animation sequence out loud to get a sense of how long the clip should last.

- 4 Mark the beginning time, envision the sequence, and then mark the end. How many seconds did it take?

For this example, assume 9 seconds. The narrative goes something like this: “Start: Approach, doorway, close up, around, around, around, around, recede, roof, back. Cut.”

- 5 To make the marked path go away, press the space bar. The red mark disappears.

Lesson 2: Setting up the Timeline for the Sequence

Time line animation settings. 9 seconds. 10 frames per second.

Now that you know your sequence will be 9 seconds, it's time to set it up and begin animating the camera.

To set up the Timeline:

- 1 Choose **File Menu menu > Animation Setup**. A dialog box appears. Enter 9 seconds in the Duration portion, and change the frames per second (FPS) to 10. Your dialog box should look like the one shown.

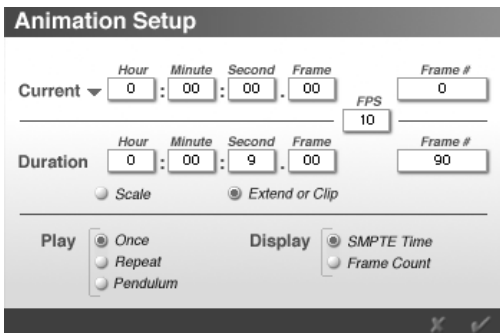

Animation Setup.

When you exit the dialog box, the Time Scrubber and Current Time Indicator fills with a green timeline.

The green extends beyond what is visible in the Time Working area. Use the Scale tool above the right end of the timeline to scale the green timeline so that you can see it in its entirety.

- 2 Drag the cursor to the right at the Scale tool. The tick marks move closer together and more of them appear from the right. Continue dragging until you can see the entire green portion of the timeline.



Scaling the timeline.

- 3 If the Selection palette is showing, toggle to the Animation palette by clicking the Selection Animation toggle in the lower right corner of the Bryce interface, or pressing the S key. The Animation palette appears.
- 4 Click the triangle on the right side of the Animation palette, then select Auto-key if it isn't already selected.



Animation palette.

- 5 Click the triangle again and select **Ticker Marks > Every 5 Frames**. A check mark appears on the menu.

If your frame rate is 10 frames per second, then a tickmark every 5 frames is equivalent to a tickmark every half a second.

You now have set up your timeline in preparation to animate the camera. Before animating the camera, think about the placement of keyframes.

Animate the Camera

Lesson 1: Setting the Camera Trajectory

To adjust the camera's trajectory:

Look at your scene from top view. The camera is located at the bottom.

- 1 Click the Add Keyframe + button to add this initial keyframe at the beginning, if needed. The key highlights to a darker green color, indicating that there is keyframe information stored for that point in time.
- 2 Drag the Scrubber three ticks to the right. The time reading is 00:00:01.05 (for one second, frame 5).
You are now ready to drag the camera to a new position for this point in time.
- 3 Drag the camera to the interior of the room, as shown.

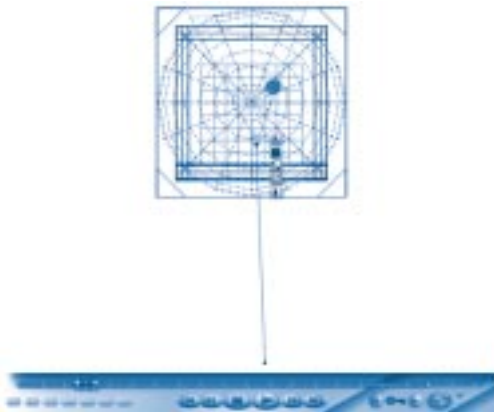

Positioning the camera.

A blue point appears where the camera was just located, and a blue trajectory line links the first point with the new camera location.

The trajectory is the line along which the camera will move.

- 4 Drag the Scrubber another three ticks to the right. The time reading is 00:00:03.00 (three seconds).
- 5 Drag the camera so that it is on the left side of the mirrored sphere wireframe, as shown. The blue trajectory follows the camera's position, and a blue point is left in the spot where the camera was previously.

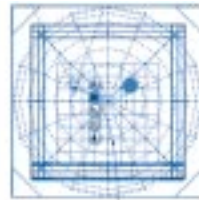

Drag to the next position.

Note: Do not drag the camera by the blue handle in the center of the camera; you will be dragging and adjusting the actual key position rather than the camera itself. We'll get into adjustment of the key position later in this tutorial.

- 6 Drag the Scrubber another three ticks to the right. The time reading is 00:00:04.05 (four seconds, 5th frame).
- 7 Drag the camera so that it is on the far side (top) of the sphere wireframe, as shown.

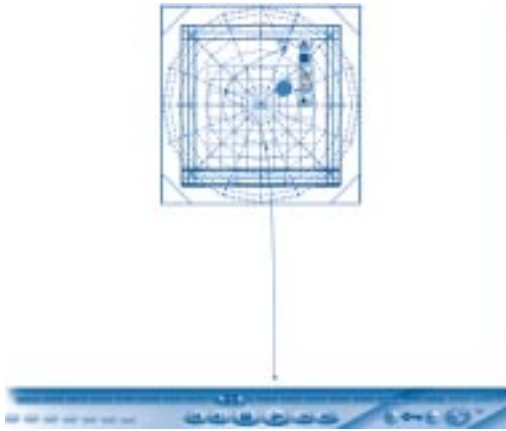

Another camera location.

Another point appears where the camera was previously, and the blue trajectory extends to this new position.

- 8 Drag the Scrubber another three ticks to the right. The time reading is 00:00:06.00 (six seconds).
- 9 Drag the camera so that it is on the right side of the sphere wireframe, as shown.

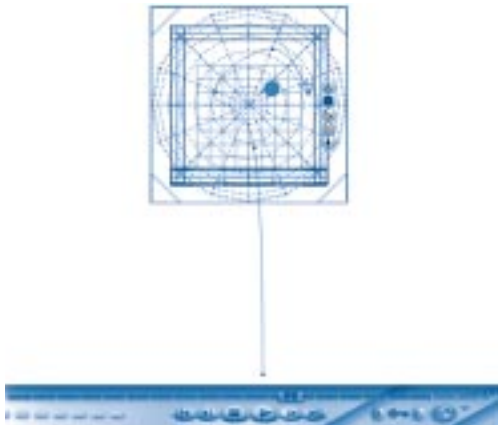

Yet another camera location.

Another point appears at the camera's previous position, and the blue trajectory extends around to this new position.

- 10 Drag the Scrubber around another three ticks to the right. The time reading is 00:00:07.05.
- 11 Drag the camera so that it crosses to the left of the path as shown.

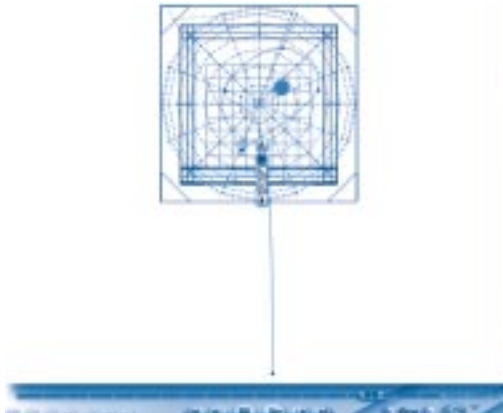

Continuing the trajectory.

Another point appears, and the trajectory extends to this new position.

- 12 Drag the scrubber the final three ticks to the right to the end of the green timeline. The time reading is 00:00:09.00.

- 13** Drag the camera well beyond the wireframe to the left of the building, as shown.

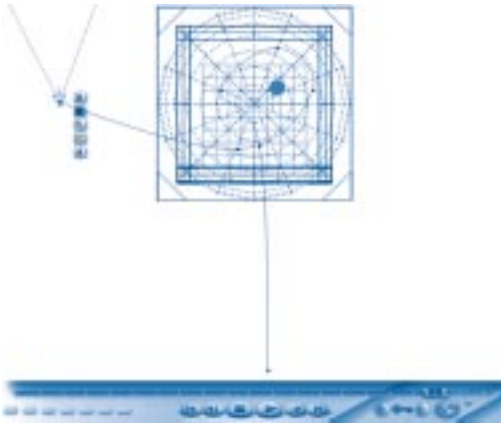

Finishing the path.

Congratulations! You have just created a camera trajectory to animate this camera. At this point, you will not be creating any new keyframes for the camera position, but adjusting the ones that are already there.

You'll no longer need the Bryce's Auto key function. To ensure that you do not inadvertently create a new keyframe during the next steps of this tutorial, you can deactivate the autokeyframe function.

- 14** Click the triangle to the right of the Animation palette, then select Auto key from the list so that it is unchecked.

Lesson 2: Pointing the Camera

Check to see what the camera does during this sequence by playing the sequence.

To point the camera:

- 1** Click the Play button. The camera moves along the blue trajectory while the Time scrubber moves from left to right.
Notice that the entire time, the camera faces in one direction. Next, you will make the camera point toward the cylinder for the entire duration of the sequence. In order to do that, you need to know the name for that particular object.
- 2** Toggle back to the Selection Palette by clicking the Selection Animation toggle in the lower right hand corner. The Selection Palette appears.
- 3** Click the Select Sphere tool. A pop-up menu appears.



Select Sphere menu.

The options are: Select All of Type, and a listing of the individual spheres by number. The sphere that you want to point at will be the bottom sphere on this list. In the figure shown, it is Sphere 4, but the number in your scene may differ. Make a note of the sphere's name; you will find it in a different pop-up menu in the next couple of steps.

- 4** Click the camera to select it. The camera's wireframe turns red and the blue trajectory line appears.
- 5** Click the Object Attributes button. The Object Attributes dialog box appears (it says Camera & 2D Projection), but it's the Object Attributes dialog box, and it's accessed using the same key commands, and so on.

- Click the center tab, called Linking. A new panel appears with options for Object Parent Name and Track Object Name.



Object Parent and Track Object Name.

- Click the Track Object Name pop-up menu and select Sphere 4 (or whatever the number for the sphere you have in your scene). The Object Name appears.
- Click the OK icon to leave the Camera's Object Attributes dialog box. The camera snaps to the right to point at the sphere, and a gray line extends from the camera to the sphere.

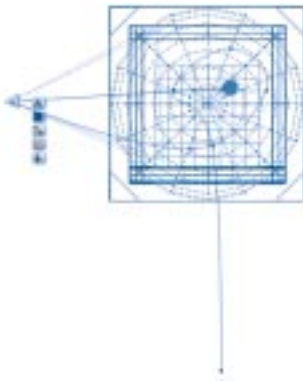

What you should see.

- Toggle back to the Animation palette and click the Play button. The camera moves along the trajectory, facing the sphere for the entire duration of the sequence.

You can view this sequence from the camera's point of view.

- Switch to Camera View by selecting **View Options menu > Camera View** or by pressing the 1 key. The wireframe view of your scene changes.
- Click the Play button to watch the wireframe animation. The camera flies through the space, all the while keeping the sphere at the center of the scene window.
- Save your scene, and call it Animation-RoughCam.

Lesson 3: Making Camera Adjustments

The camera flythrough is all at a single height, which is below the mirrored sphere and below the open arch on the left side of the building. However, the camera trajectory may have some funny little kinks in it. You can drag the points of the camera trajectory to reshape it.

To adjust the height:

- View your scene from the side by choosing **Camera View Options menu > From Right**. Your scene changes to side view. You may need to zoom out in order to see the entire camera path. Click the Zoom out tool to do so.

First, you'll adjust the camera's height so that it is level with the sphere as it circles around it.

- 2 Drag the point on the right up so that it is level with the sphere. Your scene should look like the one shown.



Adjusting the height.

- 3 Drag the other handles up except for the first and last of the camera. Your scene should look like the one shown.

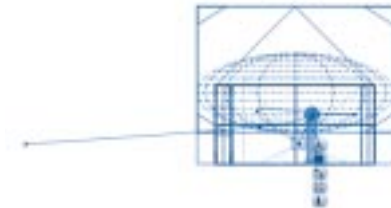

Adjusting the camera view.

To continue adjusting, you will need to look at the scene from different perspectives. More adjustments can be made from Front View.

- 4 Change to Front View by choosing **View Options menu > From Front** or press the 4 key).

Zoom out if needed, using the Zoom out tool located to the lower right of the Working Window on the Display palette.

- 5 Drag the point of the camera up so that it forms one end of a straight line between the sphere and the boolean sphere, as shown.

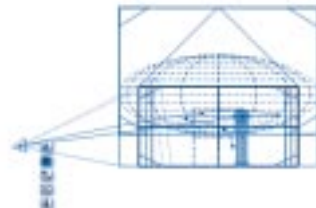

Fine-tuning the adjustments.

Note that you might need to Zoom out here to see the same view as the image above. The dotted line of the sphere is the location of the open area of the arch.

When you have dragged the trajectory point there, the camera did not follow.

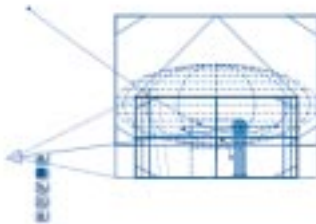

Additional adjustments.

Don't worry, when you play the animation, the camera will be located with the trajectory.

- Click the Play button and watch the camera's movement through the sequence. The camera ends up located at the end point of the trajectory.



The camera's endpoint.

Now that the camera is back on the trajectory, notice that the gray line between the camera and the sphere provides a guide for that straight line of sight. You can use the guide for other placements of your trajectory.

- Move the previous keypoint up so that it is aligned along that gray line. Your trajectory should look like the one shown.



Positioning the keypoint.

- Go back to Camera view by **choosing View Options menu > Camera View** or press the 1 key). Click the Play button to see your animation.

Lesson 4: Smoothing the Camera's Trajectory

To smooth out the Camera's trajectory, you will adjust the points positions and work with the shape of the curve using the tangents of each point. To see the tangents, you will need to make them visible.

To display the trajectory options:

- To display the trajectory, make sure Director's view is selected. If needed, choose **View Options menu > Director's View**.
- Click the Object Attributes button to access the Camera and 2D Options. Click Animation tab.

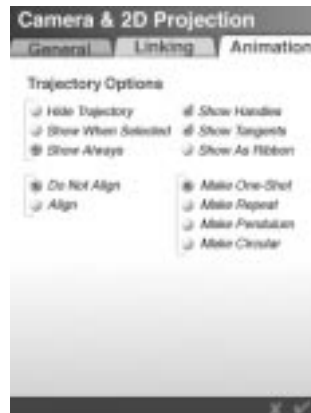

The animation tab.

- Under Trajectory Options, click the button for Show Always. Click the OK icon for Show Tangents. Exit the Camera and 2D Projection dialog box by clicking the OK icon. The camera trajectory now has gray lines extending from each point.

To smooth the trajectory:

Smoothing out the trajectory works best when you work in Top View.

- 1 Change to Top View by choosing **View Options menu > From Top**, or press the 2 key).

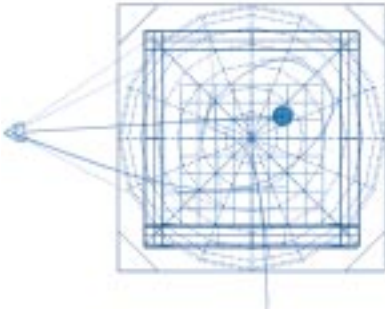

The top view.

You are returned to top view. But there are lots of items that hinder a clear view of the trajectory. The only items necessary to view are the walls and the pedestal. Since they each have their own family, it will be easy to select them and work in Solo Mode.

- 2 Toggle to the Selection palette.
- 3 Select Walls by clicking the Selection Animation toggle, then clicking the Families button and selecting Walls from the list. Then hold down the Shift key and select Family 11 to add to your selection. The walls and pedestal should be selected. In addition, the camera (which was deselected) still has the trajectory showing. It is the result of selecting Show Always earlier.

- 4 Click the Solo Mode button to change to Solo Mode. Many objects disappear, and you get a much clearer view of your camera trajectory and the tangents extending from each point.

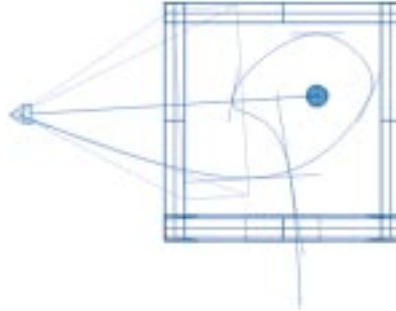

The trajectory path.

Any kinks in the path result from a lengthy tangent interfering with a neighboring point. Shortening the tangent will smooth out the trajectory line.

- 5 Click the camera to select it. The points appear.
- 6 Place the cursor over the point with the long trajectory. The cursor changes to crossed arrows.
- 7 Press the T key (for tangent), then click and drag to the right, and watch the Tangent lines shorten.

You may also reposition points to smooth out the trajectory line.

- 8 Make any other adjustments necessary to smooth out the trajectory line.

The line shown in the previous figure was changed by a slight repositioning of all the points of the trajectory except the endpoints. In addition, the next to the last point's tangent line was lengthened.

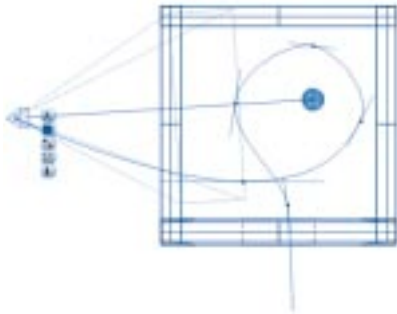

Adjusting the trajectory path.

- 9 Click the Solo Mode button to turn off Solo Mode. The other objects reappear.
- 10 Switch back to Camera View and click the Play button to view the animation now. You may need to click the Selection Animation toggle to switch back to the Animation palette, before clicking Play.
- 11 Save your scene. To see the final results, you can also open the file Animation-smoothCam, located in the Manual Tutorials folder.

Lesson 5: Test Render

It's time to set up a test render of your animation sequence. Continue with the scene file you have been working with, or use Animation-Smooth Cam scene file from the Manual Tutorials folder on the CD-ROM.

To create a rough animation, you need to change the render size of your scene to a smaller image.

To create a test render:

- 1 Choose **File menu > Document Setup**. A dialog box appears. Change the render size to 0.25, as shown. Exit the dialog box.

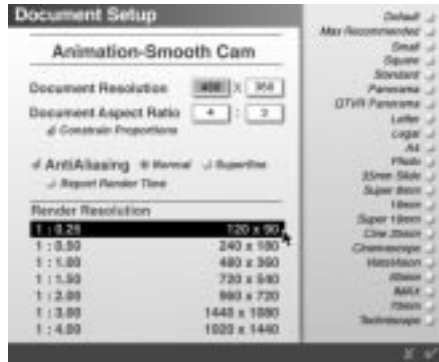

Document Setup.

- 2 Click the Render button to test render your scene. The rendered image is much smaller.
- 3 Choose **File menu > Render Animation**. A dialog box appears.

This dialog box allows you to choose your settings for this test render. There are three sections to the box-- the Range to Render, the Compression Settings, and the File location (and name).



Render Animation dialog box.

- In the Output Module section, click the Edit button. A Compression Options dialog box appears.



Compression Options.

- Uncheck the option for Keyframe every 10 frames then click OK.
Windows users should click the Output Module triangle, then select QuickTime Move. This ensures the results are consistent.
- Click the Set button. A Save dialog box appears, showing the location and name of your movie.
- Choose the location and name of your movie (add the word test), then click OK.
- Click the OK icon to exit the Render Animation dialog box. Your scene begins rendering each frame. At the end of the render, Bryce automatically launches the Movie Player application.



Playing the animation.

- Click the Play button to watch your animation.
- Switch back to Bryce and save your scene file.

Congratulations! You've created your first Bryce movie! Make sure that you exit the movie player application before you continue the tutorial.

Fine-Tuning Your Animation

To finish up your animation, you will convert your trajectory to a path. At the beginning, you used keyframes to set the position of the camera. The trajectory is good for creating the physical location of the camera over the sequence. However, the points along the path tend to correspond to places, and not necessarily events, or velocity.

Converting to a path will allow you to set up two keyframes, one for the beginning and the other for the end, and you can adjust the velocity to your heart's content without worrying about placement of this physical keyframe at that spot. As it happens, the animation we've done so far is fairly evenly paced, so the potential problem is not as apparent here as it might become later in your work animating Bryce sequences.

Lesson 1: Converting the Trajectory to a Path

To work on the timing and velocity of your sequence, you will convert your trajectory into a single path object.

To convert from Trajectory to path:

- Look at your scene from Top View.

- 2 Select your camera by clicking it.
- 3 Choose **Objects menu > Create Path**. A new path object appears, occupying the same space and shape as the camera trajectory.

The path is an object type in Bryce. You can now link your camera to that path.
- 4 Select the camera again (it got deselected when you created the path). Click the triangle on the Selection Palette, and choose Camera to select the camera. (Notice that there is an option there for selecting paths as well.) The Camera and its trajectory line are selected.
- 5 Click the Object Attributes button to access the Camera and 2D Options dialog box. Click the Linking panel to display it. For Object Parent name, select Path 1 from the pop-up menu of your objects. Click the button next to Constrain to Path. Your dialog box should look like the one shown.

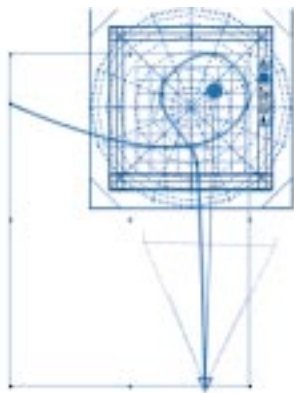

Linking Options.

- 6 Click the OK icon to leave the dialog box. The blue trajectory line disappears.

The trajectory line went away when the camera was constrained to the path. All of the keyframed motion information for the camera went away with the trajectory.

The location information of the trajectory is preserved in the path, which is present in your scene.

- 7 Click the Selection Animation toggle to switch to the Animation palette, and click the Play button. The scrubber moves, but the camera does not.

You'll re-set the keyframes for camera motion for the beginning and end of the sequence.

Lesson 2: Creating Keyframes for the Beginning and End of the Path

To create keyframes:

- 1 Click the First keyframe button on the Animation palette. The scrubber moves to the beginning of the sequence time 00:00:00.0.
- 2 Click the Add keyframe button.
- 3 Click the Last keyframe button. The scrubber moves to the end of the sequence time 00:00:09.0.
- 4 Click where the camera is located and drag to the right. The camera moves along the path.

You may have to drag several times to move the camera to the end. There is an alternative way to place the camera at the end of the path.
- 5 Click the Object Attributes button. The Camera & 2D Projection dialog box appears.

- 6 Type the number 100 in the Position box. Your dialog box should look like the one shown.



Camera and 2D Projection.

- 7 Click the OK icon to leave the dialog box. Your camera should now be located at the end of the path.
- 8 Click the Add keyframe button.
- 9 Check your animation, by pressing the Play button. Your camera should now move smoothly along the path.

You now have very smooth camera movement over a complex path, using only two keyframes.

Lesson 3: Velocity Adjustment

The last thing you will do with your animation in this tutorial is adjust the camera's velocity along the path. To do this, you will work in Bryce's Advanced Motion Lab.

Your camera should still be selected. If it is not, select it.

To adjust the velocity:

- 1 Click the Advanced Motion Lab button. The Advanced Motion Lab appears.

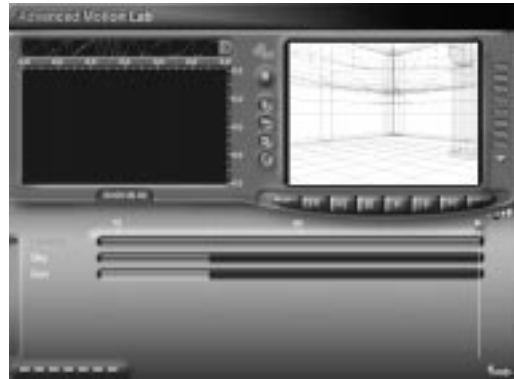

Advanced Motion Lab.

On the bottom half, the objects and their timelines are displayed. The round blue button at the upper right of the timelines is the current time display. Because of the length of the animation, you can't see the entire timeline for this sequence.

- 2 Drag the round blue current time marker to the left. The numbers and timeline bars scroll off to the right. Continue dragging left until there is no more movement.



Adjusting the timeline.

Next you will scale the timeline so that everything shows in the provided area.

- 3 Drag the scale tool to the right. (It is located under the preview window.) The space between numbers decreases, and after a bit, the entire timeline is displayed. Release the mouse.



Adjusting the scale.

The word camera displays in Red.

- 4 Click the word Camera. A number of camera attributes are displayed, as shown. Click the word Path Position.



Camera Attributes.

Additionally, in the Velocity Controls section (also known as the Time Mapping curve), a diagonal line has appeared.

Next to the window to the right is a Camera icon and a light icon.

- 5 Click the camera icon. The green light appears and the display in the right window changes to show your scene from the camera's perspective.



The camera's perspective.

See how the animation preview and the Velocity area work together.

- 6 Click the Play button under the animation preview window. The animation plays, while crosshairs mark the current time along the Velocity line.

You'll use one of the preset Velocity curves to put a little variety in the camera motion.

- 7 Click the curve that matches the one shown.



Velocity curve.

It is a slight S curve. The curve is displayed in the Velocity Controls section.

- 8 Click the Play button. The animation begins slowly, proceeds at a constant pace for a time and then slows down toward the end.

When the velocity curve is flatter, camera motion is slower. When the curve is steeper, the motion is swifter.

- 9 If you would like to try other velocity curves from the presets, click them and they'll appear in the Velocity Controls section. Play the animation and note the differences in camera velocity. A downward curve corresponds to a backwards motion along the path. When you are through experimenting with the curves, click the S shaped curve from Step 7.

- 10 Click the arrow in the lower right corner to leave the Advanced Motion Lab. You return to your scene.

The Advanced Motion Lab does not have the standard okay and cancel buttons, because all velocity adjustments are live edits. You can't undo them.

- 11 Save your scene file.

Congratulations! You are nearly there! It's time for another test render.

Lesson 4: Another Test Render

Before your test render, double-check your render settings.

To render:

- 1 Choose **File menu > Document Setup**.
- 2 In the Document Setup dialog box, ensure that you are rendering at the smallest ratio: 1:0.25.

- 3 Switch back to Camera View.

- 4 Select **File menu > Render Animation**. The Render Animation dialog box appears. Change the name of this test file to Render 2.

- 5 Click the Set button. In the Save dialog box, add "test path" to the name. Click Save.

- 6 Click the OK icon to exit the Render Animation dialog box. Your animation begins rendering.

Final Comments

Compare the two test animations. See the difference in movement?

For your final render, you may render at a larger size, or, for more fun, try creating a Volumetric World to add drama to those light rays that enter the building through the arches.

Congratulations! You have now created a scene, set up your animation, created the camera trajectory, converted the trajectory to a path, and adjusted the camera's velocity on that path. You have walked through a fair portion of the power of creating Bryce scenes and animating them.

For additional ideas of ways to animate this scene or for other tips, check out the BryceWorld website under the Links menu.



6

Creating Objects

Overview

Objects are the building blocks of your Bryce world. They can be used as props, to populate a scene, or add detail to landscapes.

An object is the most basic item in Bryce. Objects can be anything from terrains to pebbles. In Bryce, there are several ways of creating objects. Some objects use unique editors, others can be created by a simple one-step click.

There are two main tools for creating objects. The Create palette, which contains tools for creating objects with a single click, and the Preset Objects Library, which contains pre-made objects you can add to your scene.

Objects in the Scene

Every object in the scene has a bounding box. The box acts like a visual guide that tells you how much space it occupies in 3D space. It also provides access to a series of tools that let you edit an object's attributes and placement.

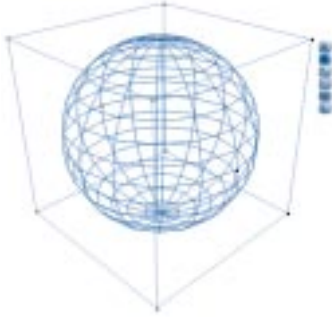

An object's bounding box lets you see how much space it occupies in 3D space.

The buttons around the edges let you set an object's attributes.

The black points on the edges of the box are called *control handles*. These handles can be used to edit the object's size and orientation. As you pass your cursor over the handles, it changes to display the type of control you're selecting.

When the cursor turns into letter, it means that you're over a constrain handle. The handle will only move along the axis indicated by the letter. For example, if the cursor changes to a Y, it

means that the handle will only move along the Y axis.

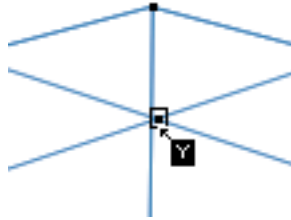

If your cursor changes to a letter, it means that you're over a constrained control handle.

Dragging this type of handle usually distorts the shape of the object.

If the handle changes to a black square with a right-angle, it means that the handle can move in any direction, but the object will be scaled proportionally.

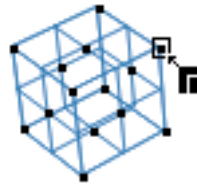

If your cursor changes to a black box with a right-angle, it means that you can use the handle to proportionally scale the object.

To display an object's bounding box:

- 1 Create an object.
- 2 Select the object.

Object Preview

When you create an object, it appears as a wireframe in the Working window. The wireframe represents the structure of the object's shape.

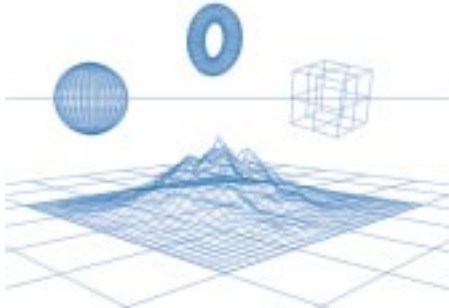

Objects appear as wireframes in the scene. The wireframe gives you an idea of the object's shape and structure.

The wireframe preview lets you see how an object looks as it's being rotated or animated without having to calculate and render any complex surface properties. The wireframe casts a shadow on the ground plane below it. The shadow can be used as a visual guide to help you determine the object's position in 3D space.

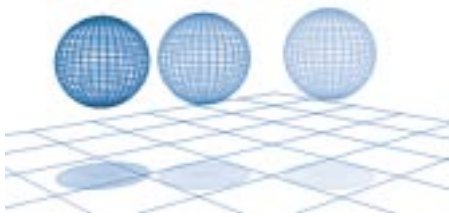

As you move the object its shadow follows it along the ground plane. When you have a number of objects, the shadows can help you see its exact position in the scene.

If you move the object below the ground plane, the portion of the object that's below ground is not drawn. This can help you avoid placing an object outside the view of the scene. Wireframe

shadows do not interact with light. These appear regardless of the light sources in the scene.

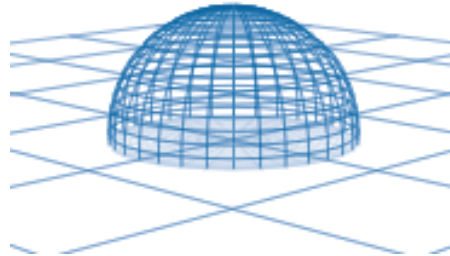

If you move an object below ground, the portion of the wireframe that's below the ground plane is not displayed in the scene.

Both shadows and underground wireframes are preview options that can be turned on and off. Refer to "Wireframe attributes" on page 18 for more on these features.

Object Preview Modes

Besides wireframes, there are three other ways you view an object; Bounding Box, Shaded Preview, and Rendered Preview.

Bounding Box

If you have a large scene and you find that it's taking too long to redraw the entire scene, you can change the display of the objects so that only their bounding box is displayed.

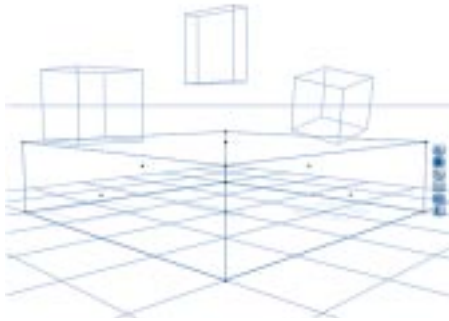

The Show Object as Box preview mode displays the object using only its bounding box.

You can move the box just as you would a normal object. The box can also cast a shadow.

To display an object as a box:

- 1 Select an object.
- 2 Click **Objects menu**> **Show Object as Box**.
or
Click the A icon that appears next to the object's bounding box to display the Object Attributes dialog.

In the dialog, click the Show as Box button.

To display an object as a wireframe:

- 1 Select an object.
- 2 Click **Objects menu**> **Show Object as Lattice**.
or
Click the A icon that appears next to the object's bounding box to display the Object Attributes dialog.

In the dialog, disable the Show as Box button.

Shaded Preview

OpenGL mode performance is greatly increased from an Open GL accelerator card, but Windows 95/98 and NT also support software-driven Open GL mode.

In this mode, objects appear as solids. The colors assigned to the object are also visible. Object surfaces are effected by light sources. Materials textures are not visible in this mode.

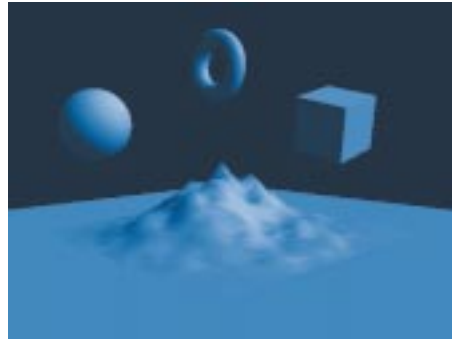

In the shaded preview mode you'll be able to see all the objects in your scene as solids.

Rendered Preview

If you want to see what the object's surface looks like or how it is affected by light gels, you'll have to render it.

The Nano-Preview shows you a small preview of what the object looks like rendered.



The Nano-Preview of the object shows you a small preview of what the object will look like when its rendered.

Refer to “Using the Nano-Preview” on page 24 for more on the Nano-Preview.

If you want to see the object at full size you’ll have to render it. Once it is rendered, you can see the bitmap preview of the object, using the Bitmap Preview mode.

Refer to “The Rendering Procedure” on page 404 for more on rendering and “Display Modes” on page 17 for more on Bitmap Preview mode.



To see a full-sized preview of the object you’ll need to render the scene.

Primitives vs. Procedural Objects

Bryce’s Create palette lets you create two different types of basic object: Primitives and Procedurals.

Primitives are basic geometric shapes such as the sphere, cube, pyramid, torus, cone, cylinder, plane, and disk. These shapes can be thought of as primary geometric building blocks, from which more complex objects are constructed.



This train is made up of primitive and primitive derivative objects.

Primitives also have derivative groups (such as the ellipsoid and squashed sphere, which are derived from the Sphere), which allow you to create different shapes without having to perform the transformations yourself.

Procedural objects are object that require special constructions, or “procedures,” to create. Procedures can include operations such as pre-assignment of materials, randomization of internal parameters, or assignment of light properties.



This scene shows examples of procedural objects.

Object Placement

When you create a new object it can be placed in your scene either at absolute world center or at an arbitrary location based on your current view. Object placement is determined by your preference setting. Refer to “To control new object placement:” on page 16 for more information.

The Create Palette

The main tool for creating objects is the Create palette. This palette provides access to tools which let you create all the object types available in Bryce.

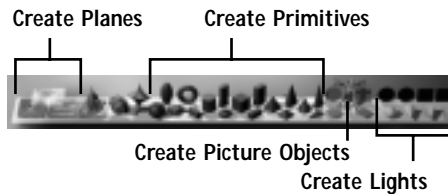

The Create palette provides access to tools you'll need to create all the different types of object available in Bryce.

The tools on the palette represent the type of object they create. When you click a tool, the object appears in the center of the scene.

The name of each tool appears in the Text Display area as you move your cursor over it.



As you move the cursor over the tool in the Create palette, its name appears in the Text Display area.

To display the Create palette:

- Click the Create button at the top of the Bryce window.

To use a Create tool:

- 1 Display the Create palette.
- 2 Click on the tool for the object type you want to create.

The object appears in the working window.

The Triangle icon next to the Create button at the top of the Bryce window lets you access the Preset Objects Library.

To open the Preset Objects Library:

- Click the Triangle icon next to the Create button at the top of the Bryce window.

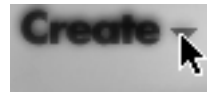

The Triangle icon next to the Create button opens the Preset Objects Library.

The Object Attributes Dialog

The Object Attributes dialog lets you set a number of properties that determine how the object appears in the Working window.

The dialog is where you'll set up the object's name, size, orientation, placement and display quality. It's most often used to numerically transform the object. When you're animating an object, the dialog is used to control how the object interacts with its motion path. Refer to

“Animating” on page 353 for more on animating.



The Object Attributes dialog contains controls for setting the object's name, scale, position, and orientation.

The dialog is divided into three tabs: General, Linking, and Animation.

The General tab contains controls for setting the object's name and display attributes and position. Refer to “Editing Object Attributes” on page 312 for more on using the dialog to edit objects.

The Linking tab contains controls for setting up parent-child links and tracking. Refer to “Linking Objects” on page 305 for more on linking and “Tracking Objects” on page 382 for more on tracking.

The Animation tab lets you set the properties of the object when it is connected to a Motion Path. Refer to “Motion Paths” on page 376 for more on motion paths.

To display the Object Attributes dialog:

- 1 Select an object.

- 2 Click **Objects menu** > **Attributes**.

or

Click the A icon that appears next to an object's bounding box.

Naming Objects

When you create an object, the first thing you should do is assign a name to it. An object's name identifies it in the Working window.

You can select objects, by name, using the Selection palette. The name can also help you distinguish a specific object when your scene contains more than one object of the same type. Refer to “Selecting Objects” on page 30 for more information.

An object's name is also used when you're creating parent-child links and setting up object tracking.

To name an object:

- 1 Select an object.
- 2 Click the A icon that appears next to its bounding box.
- 3 Enter a name in the Object Name field.

Creating Infinite Planes

An infinite plane object extends in all directions out to infinity. When you create a plane in Bryce it appears as a finite plane to make it easier to position, but when your scene is rendered the plane extends infinitely in all directions.

Though procedurally these three infinite planes are different, they are all considered to be Infinite Planes for the purpose of selecting with the Selection tools.

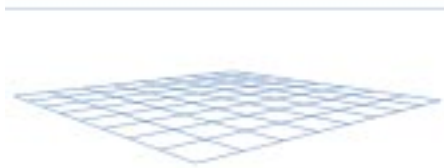

When you add a plane object it appears as a finite object in the Working window.....



...but when you render the scene it extends out to infinity

Water

Water planes are created just a bit higher than ground level. That way, if you have already created ground and terrains, you can easily place a water plane into your scene and immediately see the terrains peeking out from the water.

To create a Water plane:

- Click the Water plane tool.



Use the Water plane to add bodies of water to your environment.

Once the plane appears in your scene you can edit it like any other object. Refer to “Editing Object Attributes” on page 312 for more on editing objects.

Water planes are created with a water texture randomly chosen from the Waters & Liquids Preset Materials Library. You can change this material by selecting a different preset or creating a new material.

To change the water plane’s Preset Material:

- 1 Click the second Triangle icon at the top of the Bryce environment. The Preset Materials Library appears.
- 2 Choose a library and material then click the OK icon.

Refer to “Using the Preset Materials Library” on page 232 for more on the Preset Materials Library.

Ground

Ground planes are created at ground level. By default, all new scenes open with an infinite ground plane.

To create a Ground plane:

- Click the Ground plane tool.



Use the Ground plane to add ground to your environment.

Once the plane appears in your scene you can edit it like any other object.

The Ground plane is created with a gray color, as are all Bryce primitives. Once you begin assigning textures to objects, Ground objects

(as well as all other primitive objects) will inherit the texture assigned to the previous object.

Cloud

Cloud planes are placed much higher in your scene since they're generally the highest objects in your environment.

To create a Cloud plane:

- Click the Cloud plane tool.



Use the Cloud plane to add clouds to your environment.

Once the plane appears in your scene you can edit it like any other object.

Cloud planes are automatically assigned a randomly chosen texture from the Clouds & Fogs Preset Materials Library. You can change this material by selecting a different preset or creating a new material.

To change the Cloud plane's preset material:

- 1 Click the second Triangle icon at the top of the Bryce environment. The Preset Materials Library appears.
- 2 Choose a library and material then click the OK icon.

Infinite Slabs

An infinite slab is a plane object that has depth. An infinite plane is a plane object that has no depth. The plane has no effect on objects above it or below it; an infinite slab can affect objects within it.

For example, anything you place within the slab's depth will be affected by the slab's volume color.

Slabs are usually used to create water. When you create a water slab, you create water with realistic volume. This means that if you sink an object into the water it will be affected by the colors or textures you assign to the slab's volume.

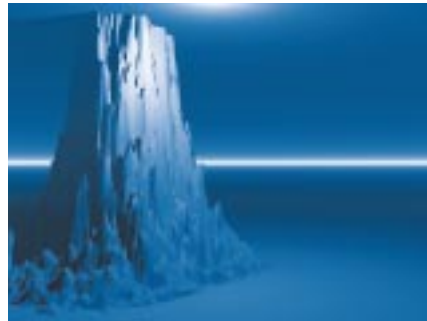

In an infinite slab, the plane in the scene has depth that affects the objects within it.

The realistic look of a water slab depends almost entirely on the material you assign to it. The Volume color plays an essential role in creating realistic water effects. Refer to "Volume Color" on page 206 for more on Volume Color and materials.

To create an Infinite Slab:

- 1 Click the plane tool and choose the Water Slab icon from the popup.



The popup that appears when you click the Water plane tool lets you choose between an infinite plane (Surface) and an infinite slab (Volume).

- 2 Select the slab.
- 3 Click the A icon that appears next to its bounding box. The Object Attributes dialog appears.
- 4 Enter a depth value in the Size Y field and click the OK icon.

Creating Stones

The Stone object tool creates random, organic Stone shapes that can be assigned materials and positioned throughout your scene.

To create a Stone Object:

- Click the Stone object tool.

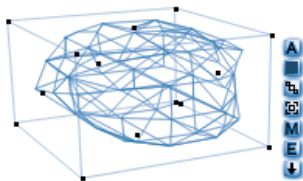

Use the Stone object tool to create randomly generated stones.

Stones objects are mesh based, and can be smoothed or unsmoothed using the Select Mesh dialog. Refer to “Editing Imported Meshes and Stones” on page 322 for more information.

Stones are assigned random textures automatically from the Rocks & Stones Preset Materials Library.

To change a stone’s preset material:

- 1 Click the second Triangle icon at the top of the Bryce environment. The Preset Materials Library appears.
- 2 Choose a library and material then click the OK icon.

Since Stones are essentially clumps of meshes, they are highly dependent on the textures assigned to them for their realism. For example, if you assign a flat texture with no bumpiness to a Stone, the results won’t be very Stone-like. Try to assign rocky textures to stones. Refer to “Using the Material Preview Area” on page 231 for more on assigning textures.

Creating Symmetrical Lattices

A Symmetrical Lattice is a terrain object that has a mirror image of itself fused at its base. When you modify one half of the lattice, the corresponding changes are applied to the mirrored half.

The Symmetrical Lattice can be a great time-saving tool. Instead of creating symmetrical shapes by duplicating and aligning two halves, you just need to edit one half of a lattice and your object is created for you. Symmetrical Lattices are edited as Terrains, using the Terrain

Editor. Refer to “Clipping Terrains” on page 184 for more information.

Many advanced types of objects can be created using the lattice object. Any object that’s symmetrical can be created by painting it’s shape in the Terrain Editor.



The hair dryer in this example was created using a symmetrical lattice object.

To create a Symmetrical Lattice:

- Click the Symmetrical Lattice tool.

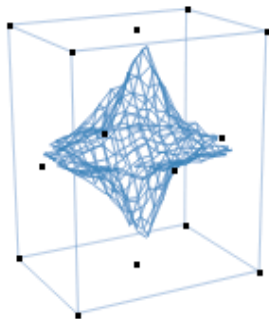
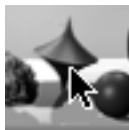

Use the Symmetrical Lattice tool to create symmetrical objects.

Creating Primitives

Primitives are the primary geometric building blocks in Bryce. You can create spheres, tori, cylinders, cubes, pyramids, cones, discs, and 2D squares.

To create a geometric primitive:

- Click one of the primitive tools:



Creates spheres



Creates toruses



Creates cylinders



Creates cubes



Creates pyramids



Creates cones



Creates discs



Creates 2D faces

By default all primitives are assigned a flat gray color.

Derivative Primitives

Derivative primitives are primitive objects whose shape is “derived” from basic geometric primitives.

Derivative primitives were created so that you could skip some of the editing procedures on most of the basic primitives. For example, instead of elongating a cube to make it into a pillar, you can just use the Stretched Cube or Brickoid derivatives.

To create a derivative primitive:

- Click one of the derivative primitives tools available:



Sphere derivatives: Ellipsoid, Squashed Sphere



Cylinder derivatives: Tuboid, Stretched Cylinder, Squashed Cylinder



Cube derivatives: Stretched Cube, Brickoid



Pyramid derivatives: Stretched Pyramid, Squashed Pyramid



Cone derivatives: Stretched Cone, Squashed Cone

Creating a Pict Object

A Pict Object is a 2D picture that is applied to a 2D finite plane. The object is basically a picture on a frame. The Frame is a 2D plane, meaning that it has no depth. If you view it from the side, it disappears.

Using a Pict Object is a quick way of creating very complex-looking objects. The only problem is that you can only view them from one angle, so the front of the Pict Object must always be facing the camera.

The Alpha channel of the object can be used to create transparencies in the Pict Object.



This object was created using a 2D Pict Object...



however, if you move the camera, the 2D nature of the object is very obvious.

A good way of ensuring that your 2D Pict Object always looks right is to have it track the camera. Refer to “Tracking Objects” on page 382 for more on tracking.

Alpha Channels and Pict Objects

The picture you use must have an Alpha channel. Refer to “Alpha Channels” on page 109 for more on Alpha channels.

The alpha channel of your Pict images will allow you to specify visible and invisible portions of your picture texture.

For example, you can clip out a picture's background so that only the main object in the picture is visible.



This is what the car image looks like with and without an alpha channel applied.

The shadow cast by the image will be in the shape of the picture's alpha channel which gives a more realistic look.

To create a Pict object:

- 1 Click the Pict Object tool or any empty square to open up the Pictures dialog.



The Pictures dialog appears:



The Pictures dialog lets you select 2D images to use as Pict Objects.

- 2 Click an image square to load an image.
- 3 If the image you want is not in the library:
 - Click the Combination Load button. The load image dialog appears.
 - Use the dialog controls to locate the picture you want to use and click Open.or
 - In another application, copy the picture you want to use to the clipboard.
 - Access the Picture dialog and click the Paste button.

The picture is loaded into the first image box and its alpha channels are loaded into the second box.



When you load a new picture into the Picture dialog, the main image is loaded into the first box its alpha channel is loaded into the second box, and the combination is loaded into the third.

You can invert the alpha channel by clicking the Invert button.



- 4 Click the OK icon to exit the dialog.

Bryce creates a 2D plane and maps the image onto it as a texture. The Pict Object is created with the same aspect ratio as the original picture.

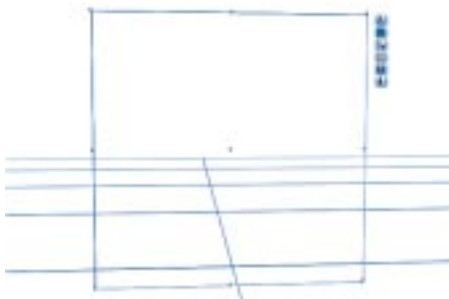

When you exit the picture dialog, the image is mapped onto a 2D plane and placed in your scene.

Working with Pictures

Pictures can be used in several ways in Bryce. They can be used as 2D Pict Objects or as components in materials or gels.

When you use a picture as an object, it is applied to a 2D plane and appears as an object in the Working window. Refer to “Creating a Pict Object” on page 106 for more on creating 2D Pict Objects.



This is what a picture looks like when it is used as an object.

When you use a picture as a material component, the image is applied to a material channel, where its values are used to drive the value of the channel. Refer to “Materials” on page 189 for more on working with Materials.



This is what a picture looks like when it is used as part of a material.

When you use a picture as a gel, the image is placed in front of the light and appears as a

projection. Refer to “Applying Gels” on page 350 for more on gels.



This is what a picture looks like when it is used as a gel.

Alpha Channels

Every image contains a number of channels that store data about the makeup of the picture. For instance channels can contain masks, colors, or bump information.

The alpha channel of an image is its first channel. The channel is like a grayscale map that accompanies an image that is used primarily as a “mask.” Areas in the alpha channel that are black are ignored by the Bryce as it computes the picture (appearing transparent). Bryce recognizes and computes areas that are white (appearing opaque).

The most common use for alpha channels is to mask the contours of a 2D object, separating it from any unwanted background information. For instance, you may import a picture of a dog. If you have created an alpha channel “mask” describing the area of the dog as white and the “non-dog” area as black, then unwanted cats and mailmen in the original picture’s back-

ground will not be seen in your rendered image.



Without Mask



With Mask

This example illustrates how the Alpha channel mask is used to eliminate the unwanted areas of an image.

In Bryce, Alpha channels are also used when your picture is a component in a material. In this case the alpha channel can be used to determine everything from the bumps in a material to how a surface property is applied on an object. Refer to “2D Textures” on page 211 for more on using pictures in a material.

If you want to use the picture in the library for multiple purposes, you’ll need to make sure that all the pictures have an alpha channel.

The Picture Library

The Picture Library stores all the images available in Bryce and can be used to catalog pictures and to import pictures. You can store any number of pictures in the library that your system memory and disk space will allow.

There are two ways of accessing the Picture Library. The method you use depends on how you're going to use the image.

To access the Picture Library from the Create palette:

- Click the Pict Object tool. The library automatically opens.

To access the Picture Library from the Materials Lab:

- 1 Select an object.
- 2 Click the M icon that appears next to the object's bounding box. The Materials Lab appears.
- 3 Click on one of the columns in the grid to activate a component window.
- 4 In the window, click the P button in the bottom-left corner. A default picture appears in the window.
- 5 Click the Pink button at the top of the window. The Picture Library appears.

To access the Picture Library from the Light Editor:

- 1 Select a light source.
- 2 Click the E icon that appears next to the object's bounding box. The Light Editor appears.
- 3 Click the 2D Texture button at the bottom of the editor. The library appears.

Previewing Pictures

The three most prominent items at the top of the library are the RGB Image, Alpha, and Combined preview windows. The first window

displays the current picture, the second window displays the alpha channel associated with the picture, and the third displays the resulting picture after the alpha channel is combined with the picture.

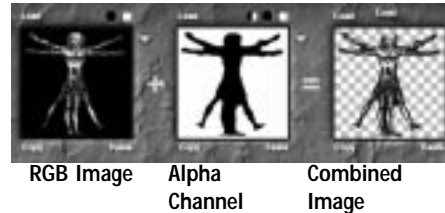

The three windows at the top of the editor display the RGM Image, its alpha channel, and the result of combining the two.

Picture Thumbnails

Below the three preview windows are the picture thumbnails that display a small preview of each picture in the library. The gray thumbnails represent empty slots in the library. When you load images, they are added to the first available gray slot.

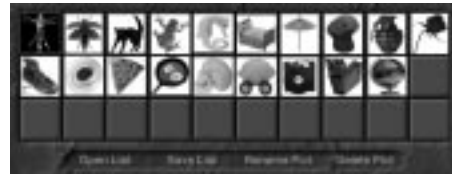

The thumbnails below the preview windows represent all the pictures available in the library.

If there are a large number of pictures in the library, you can use the scroll bar to scroll through all the thumbnails.

To display an image in the library:

- Click on the picture's thumbnail. The picture, and its associated alpha channel, appears in the three preview windows at the top of the dialog.

Loading Pictures Into the Library

You can load pictures into the library to create your own custom library. Pictures can be loaded into any of the three preview windows.

When you load a picture into the first window, you're loading only the picture's RGB (Red, Green, and Blue) color information.

The picture loaded into the first preview window replaces the currently selected picture in the library, so you're replacing a picture in the library with the picture you're loading. If you want to add a new picture to the library, you need to load it into the Combined Image window.

When you load a picture into the second window, you're only loading the picture's alpha channel.

The alpha channel determines which portions of the picture are visible and which are not. The areas of the picture that are transparent appear as a checkboard pattern.



When you load an image into the Alpha Channel window, the black and white alpha channel appears in the window.

Every picture should have an alpha channel assigned to it. If the picture does not have an

alpha channel, the resulting image appears completely white.



If there is no Alpha Channel, the image appears completely opaque.

If your picture doesn't have an alpha channel, you can copy the image from the RGB Image window into the Alpha Channel window. This way your picture won't appear completely opaque.

The Alpha channel you load does not have to necessarily match the image. You can create some interesting clipping effects by combining different alpha channels and images.



In this example, the image was combined with a different alpha channel to create a new clipping effect.

When you load a picture into the last preview window, the Combined Image window, the entire picture is loaded into the first empty thumbnail slot.

To replace the RGB information in a picture:

- 1 Click the thumbnail of the picture you want to replace.

- 2 Click the Load button on top of the RGB Image window. The Load dialog appears.

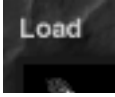

The Load button displays the Load dialog which lets you select a picture to load into the RGB Image window.

- 3 Use the dialog controls to locate the desired image and click Load.

The picture appears in the first preview window.

To replace the Alpha channel information in a picture:

- 1 Click the thumbnail of the picture you want to replace.
- 2 Click the Load button on top of the Alpha Channel window. The Load dialog appears.
- 3 Use the dialog controls to locate the desired image and click Load.

The picture's alpha channel appears in the first preview window.

To load a new picture into the Library:

- 1 Click the picture slot in the bottom of the library where you want to load the new picture.
The Load dialog appears.
- 2 Use the dialog controls to locate the desired image and click Load.

The picture's thumbnail appears in the picture slot.

Copying and Pasting Pictures

Copying and pasting in the Picture Library works differently for each of the three image windows.

When you copy and paste into the first window, you're only pasting RGB color information, so if you copy an image from the Combined window, only the color information is pasted into the RGB window.

As with loading, any changes you make in the RGB Image window changes the selected image.

When you copy and paste into the second window, you're only working with the Alpha Channel information, so any image you paste into this window will appear as an alpha channel image (i.e. black and white). Any changes you make in this window affect only the selected image.

When you copy an image from the Combined window the entire image is placed on the clipboard. Depending on where you paste it, only a portion of the image may be used.

When you paste a picture into the Combined window, it appears as a color image with transparent and solid areas. All pictures are treated as color. So if you paste a picture copied from the Alpha Channel window in this window, you'll get an RGB representation of the alpha channel image. As well, any image pasted into this window creates a new picture entry in the library.

To copy and paste RGB information in a picture:

- 1 Click the Copy button below the RGB Image window.



The Copy button places the contents of the RGB Image window on the clipboard.

- 2 Click the Paste button below the window where you want the RGB image to appear.
 - If you paste the image into the Alpha Channel window, it is desaturated and used as an alpha channel.
 - If you paste it into the Combined Image window, the RGB image becomes a new entry in the library.

To copy and paste Alpha Channel information in a picture:

- 1 Click the Copy button below the Alpha Channel window.
- 2 Click the Paste button below the window where you want the Alpha Channel information to appear.
 - If you paste the image into the RGB Image window, an RGB representation of the alpha channel is placed in the window.
 - If you paste it into the Combined Image window, an RGB representation of the alpha channel is placed in an empty slot in the library.

To create a new picture using RGB color information only:

- 1 Click the Copy button below the RGB Image window.
- 2 Click the Paste button below the Combined window. The RGB information is placed in an empty slot in the library.

To create a new picture using Alpha channel information only:

- 1 Click the Copy button below the Alpha Channel window.
- 2 Click the Paste button below the Combined window. The alpha channel information is placed in an empty slot in the library.

Deleting Pictures

When you delete a picture, you remove all the image information (including color and alpha channel) from the library.

To delete a picture from the library:

- 1 Click the thumbnail for the picture you want to delete.
- 2 Click the Delete Pict button.

To delete all pictures from the library:

- Click Delete All.

Inverting the Alpha Channel

When you invert an alpha channel all the black areas become white and the white areas become black. This means that all the areas that were transparent now become solid and vice versa.

To invert an alpha channel:

- Click the Invert button above the Alpha channel window.



The Invert button swaps all the black and white values in the alpha channel.

Picture Lists

A Picture List is a file that contains a group of pictures. A Picture list can be used to store all the pictures used in a given scene, or to store a series of pictures you use most often.

You should also use a picture list to store any pictures you've used as part of material.

There are several Pict texture List files provided as samples for your first excursions.

To open a picture list:

- 1 Click the Open List button at the bottom of the Picture Library. The Open dialog appears.
- 2 Use the dialog controls to locate the desired list and click Open. The pictures in the list appear in the library.

To save a picture list:

- 1 Click the Save List button at the bottom of the Picture Library. The Save dialog appears.
- 2 Enter a name for the list and click save.
Name the list the same as the scene. This way, you can easily find the list that belongs to a specific scene.

Importing Objects

Bryce can open many different file formats, including files created in previous versions of Bryce. For instructions on importing files as well as a list of all import formats, see the README file on your Bryce CD ROM and Appendix 17 , “Using Bryce with Other Applications.”

Creating Boolean Objects

A Boolean object is an object created by combining two or more objects to form a single object. Boolean objects are created by performing Boolean operations on a number of objects. You can perform three types of Boolean operations in Bryce: union, subtraction, and intersection.

Bryce uses Object properties to perform Boolean operations. Objects can be Neutral, Positive, Negative, or Intersecting. When you combine these objects in a group, the result is a Boolean object.

Boolean operations do not have any effect on Neutral objects. When you group a neutral object with a Boolean object, no Boolean operation is performed.

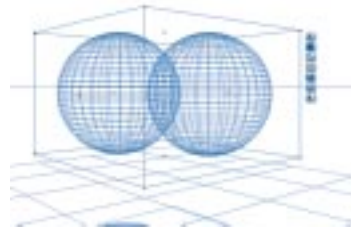
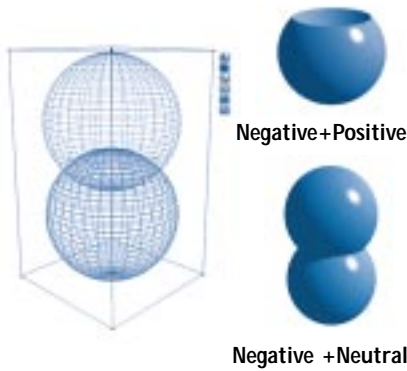

If you were to group a neutral object with a Boolean object, both objects would remain visible with no Boolean operation occurring.

Neutral is the default object property.

If you are importing objects from Bryce 2, you may want to change some positive objects to neutral for faster rendering.

Boolean union is performed by grouping two positive objects

Boolean Subtraction is performed by grouping a negative object with a positive object. The area that is common to both objects is subtracted from the positive object resulting in a positive object with negative space. For example, when you group a positive sphere with a negative one, the resulting object looks like a sphere with a crater.

Boolean Operations

Boolean Union is performed by grouping two positive objects. The area that is common to both object is removed, creating a continuous object. For example, when you group two positive spheres, you get a kind of peanut shaped object which is the union of the two objects.

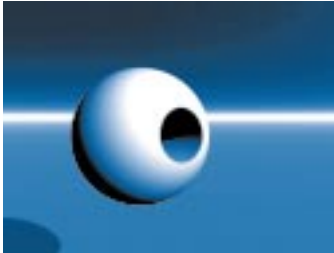
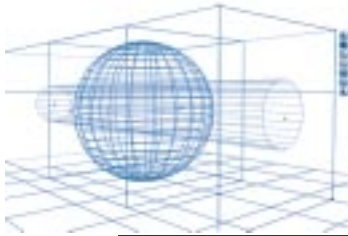

Boolean subtraction is performed by grouping a positive object with a negative object.

Boolean Intersection is performed by combining an Intersecting object with a Positive object. The area that is common to both objects becomes the only visible portion of the group.

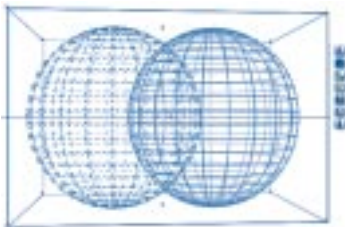

Boolean Intersection is performed by grouping a Positive object with an Intersecting object.

Negative or Intersecting objects must share space with at least one Positive object in the group to exhibit a Boolean operation. If there is no common space, Negative objects are invisible when rendered.

A group that contains an Intersecting object that does not intersect with any other object in the group becomes entirely invisible; this is because the Intersecting object is intersecting with nothing.

You can build very complex objects by compounding Booleans. Suppose you wanted to create a flute. You would first create the hollow tube by combining a positive cylinder with a negative cylinder, then create several negative spheres and group those with the tube, creating a simple flute.



This simple flute was created by grouping a hollow tube with several negative spheres.

By compounding more Boolean operations on top of this simple flute you could create even more complex objects.



This sprinkler was created using compound Boolean operations.

Since Bryce performs Boolean operations using object attributes, you can adjust the shape of a Boolean object by repositioning the objects in the group. You can edit objects within groups using the Solo mode in the Selection palette. Refer to “Selecting Objects” on page 30 for more.

The final Boolean object appears only in the rendered image or in the Nano-Preview. You won't be able to see the Boolean object in the Wireframe preview.

To subtract one object from another:

- 1 Select an object.
- 2 Click the A button next to the object's bounding box, or press Command-Option-E/Ctrl+Alt+E, or choose **Objects menu> Edit Attributes**.
The Object Attributes dialog appears.
- 3 Enable the Negative checkbox.
- 4 Move the negative object so that it intersects another object.
- 5 Make sure that the second object's Boolean attribute is set to Positive.
- 6 Select both objects and click the G button next to the selection's bounding box to group them.

When your scene is rendered, the area where the two objects intersect is removed from the positive object.

To create an object that is the intersection of two objects:

- 1 Select an object.
- 2 Click the A button next to the object's bounding box, or press Command-Option-E/Ctrl+Alt+E, or choose **Objects menu> Edit Attributes**.

The Object Attributes dialog appears.

- 3 Enable the Intersecting checkbox.
- 4 Move the intersecting object so that it intersects another object.
- 5 Make sure that the second object's Boolean attribute is set to Positive.
- 6 Select both objects and click the G button next to the selection's bounding box.

When your scene is rendered, the area where the two objects intersect becomes the only visible portion of the group.

Creating Geometric Paths

A geometric path is an object that acts as a motion path for other objects. Geometric Paths do not render as objects.

You can think of these paths as railroad tracks. Objects can move along the track but they can't move off of it.



Objects attached to a geometric path can move to any point along the path, but they can't move off it. So, their trajectory is controlled by the shape of the path.

You can control how an object is constrained to the path using the options in the Object Attributes dialog.

Geometric paths can be edited just like you would any other object. You rotate, position, or scale the path using the tools in the Edit palette. You can also edit a path by dragging its control points. This way can change the geometry of the paths as well as the trajectory of any object attached to it.

Geometric paths are especially useful when you creating motion animations, as they can help you create predictable and repeatable motion.

The other great thing about geometric paths is that you can have more than one object attached to it. This can be very useful if you want a number of objects to move along the same trajectory.



You can attach multiple objects to the same path. The motion of each object on the path is constrained by the shape of the path.

Objects that are attached to the same path can be animated at different rates. So, if you can think of the objects as different trains on the same track, some trains are at the beginning of the track, others are in the middle, and some are at the end. All the object attached to the path will have the same trajectory.



All the objects attached to a path have the same trajectory, but they can move at different rates.

For example, this caterpillar is made up cylinders all attached to the same path, but they're moving a different rates so it looks like the body is slithering.

You can also align objects differently to the same path. So object may appear to tilt differently as they follow the same trajectory.

Since geometric paths are objects, they can also be attached to other paths. Some very complex types of motion can be created using this technique.



For example, you can simulate the motion of the solar system by attaching an object on a circular path to circular geometric path.

The object on the circular path would act like a moon orbiting around a planet which is also orbiting around the Sun.

To create a geometric path:

- Choose **Objects menu > Create Path**.
A default-shaped path object appears in your scene.

To convert a motion path into a geometric path object:

- 1 Select an object with a motion path.
- 2 Choose **Objects menu > Create Path**.
A path object with the same shape as the path you selected is created.

To link an object to a path:

- 1 Select the object you want to attach to the path.
- 2 Move the cursor over the Link icon that appears next to its bounding box.



- 3 Drag the linking control handle from the object to path object.

Using the Presets Object Library

The Presets Object Library contains all the pre-set objects distributed with Bryce as well as presents you add. Objects in the library are either 3D models or geometric paths. Refer to “Creating Geometric Paths” on page 117 for more on geometric paths.

You can place objects from the library anywhere in your scene and edit them just as you would any object.

To add an object from the Preset Object Library to your scene:

- 1 Click the Triangle icon next to the Create button at the top of the Bryce environment. The Object Preset Library appears.

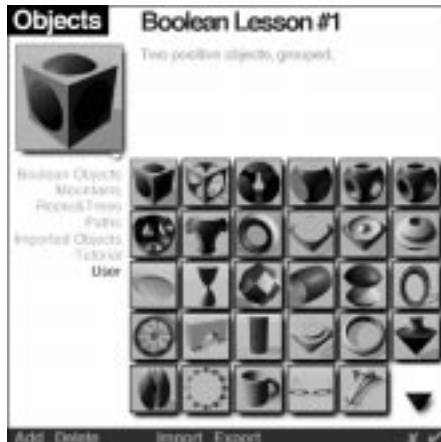

Use the Preset Object Library to add 3D models to your scene.

- 2 Click on the name of a category (to the left of thumbnails).

- 3 Click on the preset thumbnails to view preset names and descriptions
- 4 Click OK to add the selected object to your scene.

The Create palette does not need to be active for you to access the Object Presets Library.

Adding and Deleting Preset Categories and Objects

You can add preset categories (such as flowers, trees, and rocks) or specific objects (within categories) to the preset library. The preset library retains all Boolean, grouping and textural properties of the objects placed within it.

To add a preset category:

- Choose Add Category and enter a category name.

To delete a preset category:

- Select the name of the category.
- Click Delete Category.

To add an object to the preset library:

- 1 Select the object you want to add to the library.
- 2 Click the Triangle icon next to the Create button at the top of the Bryce window. The

selected object appears in the preview area of the Object Preset Library dialog.



The object preview area displays the object you selected.

- 3 Click a category name. The library switches to the category you selected. The new preset will be added to the category you select.
- 4 Click the Triangle icon in the bottom right corner of the object preview and choose a view option from the menu.



Use the Triangle icon at the bottom of the preview area to display a list of preview options.

Normal is the default view of your selected object.

Up Close displays a close-up of your object.

Render With Neutral Sky displays your object with a flat sky, instead of the sky applied to your scene.

- 5 Set up the preview of the object:
 - Drag the preview area to rotate the view of the object.

- Hold down the Spacebar and drag up, down, right, or left to pan the object preview.
- Hold down Command/Ctrl and drag in the preview area to zoom in and out of the preview.

- 6 Click the Add button at the bottom of the dialog. The Add Object dialog appears.
- 7 Enter a name for the new preset in the Preset Name field.
- 8 Enter a description of the preset in the Description field and click the OK icon.
This name and description will appear beneath the object preview whenever the preset is selected.
- 9 Click the OK icon. Your preset is added to the first available space within the current category.

To delete an object preset:

- 1 Click the Triangle icon next to the Create button at the top of the Bryce environment. The Preset Object Library appears.
- 2 Click on the preset you want to delete, or hold down Shift and select a continuous series of presets, or hold down Command/Ctrl and select a discontinuous set of presets.
- 3 Click the Delete button at the bottom of the dialog.

Importing and Exporting Preset Objects

Importing and exporting presets is a handy way to exchange custom presets with other users.

To import a Preset object file:

- 1 Click the Triangle icon next to the Create button at the top of the Bryce window. The Preset Objects Library appears.
- 2 Select the category into which you want to import the file.
- 3 Click the Import button at the bottom of the dialog. The file open dialog appears.
- 4 Locate the file which you would like to import and click Import.
The contents of the file are placed into the first available space in the current category.

To export a Preset object file:

- 1 Click the Triangle icon next to the Create button at the top of the Bryce window. The Preset Objects Library appears.
- 2 Select the category from which you want to export presets.
- 3 Select the preset or presets you wish to export.
- 4 Click the Export button at the bottom of the dialog. The save file dialog appears.
- 5 Enter a name and location for the file and click Save.



7

Creating Skies

Environments and Bryce

A Bryce sky defines the virtual environment of your scene. Unlike many other 3D applications, Bryce's virtual environment is not merely a backdrop, it is an infinite 3D representation of natural environmental phenomena.

All of the elements in your sky interact with each other just as they would in the real world. Colors in your environment interact with everything in your scene just as they would in nature. For example, red sunlight is invisible until it strikes an object, then the object exhibits red highlights. If it's a blue object, it takes on a purple cast and so on.

The colors in the sky change depending on the position of the sun, and how much moisture (Haze, Fog) is present in the atmosphere. All this, plus natural reflection, refraction, and more make Bryce's Sky & Fog palette

responsible for a great deal of the natural, or supernatural, look and feel of Bryce images.



The objects in your scene may look incredibly realistic on their own...



...but when you add a sky, the scene becomes a window looking out into a real world.

You can add even more realism to a sky by enabling one of the many environmental effects available for skies. Using these effects you can create night skies full of stars, or have a bright rainbow streaking across the roof of your world. One of the most spectacular effects is the Volumetric World effect. When this effect is enabled all the light in your scene appears as

visible rays. This is similar to the effects of light shining through clouds on a hazy day.



The other-worldly look of this spaceship landing was created using Volumetric World.

Like any other scene setting, skies can be animated. Any property of a sky can be changed at different points along the animation timeline. When the animation plays, the sky property will appear to change over time. Using this technique, you can create a scene that changes from day to night, or from clear to cloudy. Refer to “Animating Skies” on page 393 for more on animating skies.

The Sky & Fog Palette

The Sky & Fog palette is where you’ll set up the attributes of your environment. The palette uses visual controls in the form of thumbnails

to help you see how changing the value of an attribute affects your sky.

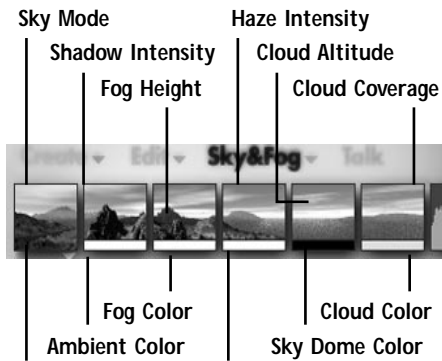

Sky Mode Options Haze Color

The Sky & Fog palette's thumbnails let you set values for sky attributes.

The name of the control you're adjusting appears in the Text Display area of the Control palette. You can also use this area to help guide you if you prefer numeric precision.



The Text Area displays the name of a Sky & Fog control as you pass the cursor over it. When you're adjusting the setting of a control, this area displays its current value.

Each control has at least one color swatch along the bottom of the thumbnail. These swatches are used to set the color for a given sky attribute, like cloud color or fog color.

Next to the thumbnails are a series of controls that let you set the frequency and amplitude of clouds, the position of the sun or moon and store sky properties. You can see their effects in the Preview area.

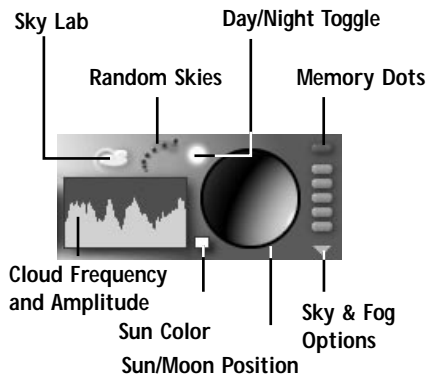

The set of controls at the end of the palette does not have visual guides, but you can see their effects in the Preview area.

Working with Sky Lab

The Sky Lab button provides access to the Sky Lab dialog. This dialog contains controls for fine-tuning environmental effects like clouds, rainbows, and sun and moon rings. Click the Sky Lab button, which looks like a cloud with a rainbow, in the Sky & Fog palette, to display the Sky Lab dialog. You can also click the triangle icon below the memory dots and choose Sky Lab from the menu.

The dialog contains three tabs:

- Sun & Moon contains controls for positioning the sun and moon as well as adding effects like rings and horizon illusions.
- Cloud Cover contains controls for editing cloud textures and setting up cloud animations.
- Atmosphere contains controls for rainbows, visible lights, and color blending.

You can preview your changes in the Sky Lab dialog.

- To view the different preview options, click the downward pointing triangle at the lower corner of the preview area. You can also change the camera position in the preview area.
- To change the position of the camera, hold the Option/Alt key and drag the preview. To orbit around the scene, drag the preview in the direction you want to move the view of your scene.

Working with the Sky & Fog palette

The Sky & Fog palette has several settings that you can use to control how the palette affects your scene and how the sun tracks your camera view. You can also use the palette's memory dots to store settings as you experiment with different environmental attributes.

Using the Control Thumbnails

The thumbnails are visual guides, and they are also used to set the attributes of Sky & Fog effects.

To change the intensity of an effect:

- Drag to the left or right inside the thumbnail to change the intensity of the effect.

To pick a color for an effect:

- Click the color bar below the thumbnail. A color picker appears and your pointer changes to an eyedropper.

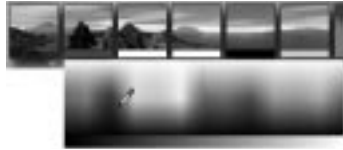

Click on the bar below the thumbnail to access the color picker.

While the eyedropper is active, you can select colors from anywhere in your scene, or even different parts of the interface.

For more control after picking with the color picker, try Option-click/Alt+click to get Bryce's second color editor, switch to HLS mode and adjust saturation or lightness (less saturated colors can make for more realistic fog and haze effects), or you can enter numeric values if you need to precisely match specific colors.

Setting Palette Options

The Sky & Fog palette options let you link the palette controls directly to your scene and link your sun to the camera.

To link Sky & Fog attributes directly to your scene:

- Click the triangle icon below the memory dots at the right edge of the palette and choose Choose Auto Update from the menu.
- When this option is enabled, every change you make to the Sky & Fog palette settings will start a render of your scene with the new sky settings.

Note

Unless you have marquee'd a small region to be updated, every change you make will begin a completely new render.

To reset Sky & Fog palette settings to their defaults:

- Click the triangle icon below the memory dots at the right edge of the palette and choose Reset Sky from the menu.

Saving Sky & Fog settings

The memory dots in the Sky & Fog palette let you store your favorite Sky & Fog settings. Using these dots you can safely explore many Sky & Fog configurations without losing your favorite settings along the way. Memory dots appear along the right side of the palette.



Use the Memory dots to store your favorite Sky & Fog settings.

To save Sky & Fog settings:

- In the Sky & Fog palette, click on an empty dot (empty dots are gray).
All the current Sky & Fog palette settings are stored into the selected dot.

To switch to a saved Sky & Fog setting:

- Click on a full dot (full dots are turquoise.)
The current settings are replaced with the settings stored in the dot.

An active dot will be turquoise with a white point inside it.

To reset Sky & Fog settings to default:

- In the Sky & Fog palette, click the uppermost memory dot. This dot always appears full.

To delete a saved Sky & Fog setting:

- Option-click/Alt+click on a full Memory Dot.

The uppermost dot cannot be cleared.

Memory dots are saved with the scene, but not between sessions, so you may want to save your favorite skies as presets before ending a Bryce session.

Randomizing Skies

Randomizing skies is a very powerful way of exploring possibilities you may never find any other way. When you randomize the sky all the settings in the palettes are replaced by randomly generated values.



Click the Randomize Sky button to randomly generate sky settings.

To randomize your sky:

- Click on the Randomize Sky Button.
Remember, you can always return to the default settings by clicking on the top Memory Dot.

Working with Sky Modes

The Sky modes act as the base of your sky. The Sky modes control lets you set the base colors and light tones for your environment. There are four modes available: Soft Sky, Dark Sky, Custom Sky and Atmosphere Off.

As you switch between the modes, the thumbnail also changes to give you a preview of what the mode looks like.



The four Sky modes control the base colors and tones used to create your sky.

To select a sky mode:

- Click the Sky mode thumbnail to cycle through the four modes, or
- Drag left or right inside the thumbnail to cycle through the modes, or
- Click the triangle icon next to the thumbnail and choose a mode from the menu.

Sky Modes

Soft Sky is the default state of the sky. It features softer shades of blue and lighter tones.



Darker Sky is a darker version of Soft Sky. It uses darker shades of color and tones. This mode is good for creating more brooding skies.



Custom Sky lets you choose your own colors for the sky; this way you can create some truly alien environments. When this mode is selected, the standard behavior of colors in the sky with respect to sun position is disabled.

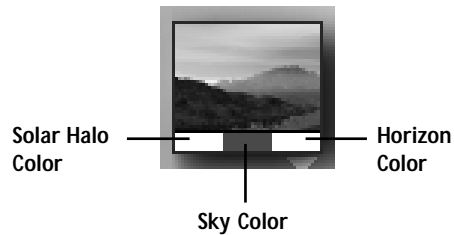

In Custom Sky mode you can pick your own colors for the sky.

Atmosphere Off disables the standard sky color behaviors, relative to sun position, and uses a single color for the sky. This mode is useful when you need to render objects against a simple colored (or black or white) background. The Sun color still affects objects in this mode. If you have red sunlight, for instance, objects in your scene will reflect red light.



To set custom sky colors:

- 1 Click the triangle icon next to the Sky Mode thumbnail and choose Custom Sky

from the menu. The thumbnail changes to the Custom Sky control.

- 2 Click the Sky Color swatch and choose a color from the color picker.
The Sky Color is the main sky color in this mode, regardless of sun position.
- 3 Click the Solar Halo Color swatch and choose a color from the color picker.
This is the color of the halo around the sun.
- 4 Click the Horizon Color swatch and choose a color from the color picker.
This color will in certain cases affect your scene below ground level if you have a haze setting of greater than zero. It will also impact the color of Stratus clouds near the horizon.

In most cases, this will be the least obviously used color in your scene; unless you are making outer space scenes, in which case this could be very useful for you.

To render objects against a plain background:

- 1 Click the triangle icon next to the Sky Mode thumbnail and choose Atmosphere Off from the menu. The thumbnail changes to the Atmosphere Off control.
- 2 Click the Atmosphere swatch and choose a color from the color picker.
- 3 Drag left inside the Haze control and set the value to 0. This setting eliminates the suggestion of a horizon.

Setting Sky Attributes

Once you've selected a Sky mode you have the basis for your virtual environment. All the other atmosphere effects you add later will interact with the base mode. There are two other attributes that affect how all the other effects will appear: Shadows and Ambient color.

Shadows in Your Scene

All the objects in your scene cast shadows. Using the Shadow control you can set the intensity and color of all the shadows in your scene.

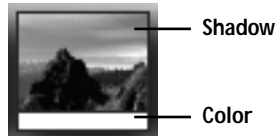

Use the Shadows control to set the color and intensity of shadows in your scene.

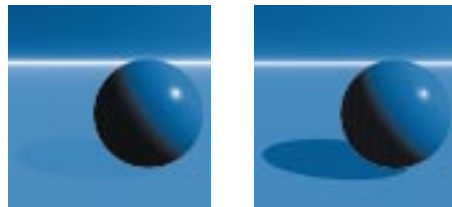

As you change the value of the Shadow control, the brightness of shadows changes.

The shadow control is not the only control for shadows. The position of shadows is dependent on the position of the sun. Since the sky interacts directly with objects in the scene, the color of the sun also effects the color of shadows.

The object's material properties also effect the color of shadows. Semi-transparent or transparent objects with a transparency color

will change the color of the object's shadow. As well, volume materials can dramatically change the shape and color of shadows.



Use the Shadows control to set the color and intensity of shadows in your scene.

By default, the Clouds in Bryce do not cast shadows. If you want the cloud layer to cast shadows on the ground below, enable the Cloud Shadows option. Refer to "Cloud Coverage" on page 140 for more on this option.

To set shadow intensity:

- 1 Display the Sky & Fog palette by clicking the Sky & Fog button at the top of the Bryce window.
- 2 Drag left or right inside the Shadow control thumbnail. Dragging left decreases the intensity and dragging right increases it.



The cursor changes to a two headed arrow as you drag over the control.

To set shadow intensity numerically:

- 1 If it's not already visible, display the Sky & Fog palette by clicking the text item on the menu bar.
- 2 Click the Sky Lab button. The Sky Lab dialog appears.



Use the Sky Lab dialog to set sky attributes numerically.

- 3 Click the Sun & Moon tab to display the Sun & Moon palette.
- 4 Click the Shadow field, then enter a value, or drag the slider. This field governs the intensity of shadows rendered in your image. The range is 0 to 100%, and the default value is 90%.

Ambient Color

The Ambient Color is the color of all the light that surrounds the objects in your scene. Light from the sun interacts with ambient color to produce the color for both highlights and shadows.

Ambient Color is used as the source color for material Ambience. The Ambient Color tints the surfaces of all objects in your scene that have some level of ambience. Any other color you apply to the object's surface is mixed with

the Ambient color to create the final surface color. For example, if the Ambient Color is red, any color you assign to an object's surface ambience is mixed with red.

Refer to "Ambience" on page 197 for more on material ambience.

To set Ambient Color:

- Click the color swatch below the shadow control thumbnail and choose a color from the color picker.
For realistic effects, at noon, or in the afternoon, ambient color should be a little blue to get nice blue-ish shadows. At dawn, you can set Ambient Color to red or pink, and at night you can set it to gray-blue.

Adding Fog and Haze

Fog and Haze are two atmospheric effects that can add realistic depth to your scene. Fog can make objects appear to disappear the farther they get from the camera. Haze can add the illusion of a distant horizon. The Fog and Haze controls in the Sky & Fog palette let you control the color and intensity of these effects.

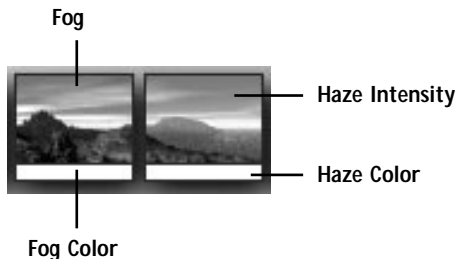

Use the Fog and Haze controls to set the intensity and color of Fog and Haze effects.

Fog

Fog can add an element of sensuality, mystery, and even realism to your scenes. It acts like a thin layer of cloud close to the ground. Using Fog you can create the illusion of depth without having to add distant objects.



Fog can create a sense of depth in your scene. In this scene, the fog was used to add depth to the road as it moves away from the camera. Notice how the feeling of depth was created without the addition of background objects.

You can set intensity, height and color attributes for the fog.



Fog=10



Fog=90

For example, you can see how the fog changes in these skies as the Fog value changes.

The fog acts as a global layer covering the entire scene. Its color and intensity are the same throughout the scene.

To set the amount of Fog:

- 1 Display the Sky & Fog palette by clicking the Sky & Fog text button.

- 2 Drag horizontally inside the Fog thumbnail to increase or decrease the amount of fog in your rendered scene. Drag to the left to decrease the amount of fog and to the right to increase it.

To set Fog height:

- 1 Display the Sky & Fog palette by clicking the Sky & Fog text button.
- 2 Drag vertically inside the Fog control to increase or decrease the height of your fog. Drag up to increase the height and down to decrease it.

The height and amount values are displayed in the Text area of the Control palette as you drag.

To set Fog color:

- 1 Display the Sky & Fog palette by clicking the Sky & Fog text button.
- 2 Click the color swatch beneath the Fog thumbnail and choose a color from the color picker.

To set Fog attributes numerically:

- 1 If it's not already visible, display the Sky & Fog palette by clicking the text item on the menu bar.
- 2 Click the Sky Lab button. The Sky Lab dialog appears.
- 3 Click the Atmosphere tab.
- 4 Click the Fog Density and/or Thickness fields then enter a value. These fields set the amount of fog rendered in your image. The range is 0 to 100%, and the default value is 0%.
- 5 Click the Base Height field, then enter a value. This field sets the height of fog

rendered into your scene, assuming there is a value greater than zero in the Fog field. The range is 0 to 100%, and the default value is 0%. It translates the entire atmospheric effect up or down without changing the density or thickness.

Base Height provides control over density at low altitudes, such as in valleys. In earlier versions of Bryce, you had to move the entire scene up or down relative to the atmosphere.

Blending the Fog Color

Since the fog remains constant throughout the scene, you may get some odd looking results when you're creating a sunset or sunrise. In these cases the sun is very close to the ground plane where the fog exists, so the fog should react to the sunlight. The Blend with Sun feature lets you create exactly this effect. As the sun approaches the Fog, the color and intensity of the fog changes to interact with the color of the sun.



In this example, the Fog is linked to the sun so you can see the changes in the fog color and intensity as the sun gets closer to the horizon.

To link Fog color to the Sun controls:

- 1 If it's not already visible, display the Sky & Fog palette by clicking the text item on the menu bar.
- 2 Click the Sky Lab button. The Sky Lab dialog appears.
- 3 Click the Atmosphere tab.
- 4 Click the Blend with Sun button.
- 5 Make sure the Blend Fog button is enabled.
- 6 Enter a value in the Color field, or drag the slider, to set how much of the fog color is blended with the sun.
- 7 Enter a value in the Luminance field, or drag the slider, to set the intensity of the fog color when it's blended.
To get the best effect, set both these fields to 100.

Localized Fog

There may be times when you want to create localized pockets of fog. For this type of effect you'll need to use an object with a volume material applied to it; this way the object looks like fog. The area covered by the fog is then controlled by the size of the object. A flattened sphere usually makes a good fog volume.

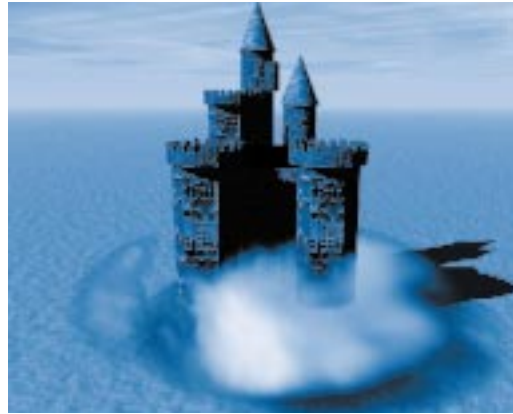

In this example, fog only appears around the base of the castle. This effect was created by applying a volume material to a flattened sphere object.

This technique can also be used to create visible smoke, or gas.

To create localized fog:

- 1 Display the Create palette.
- 2 Click the Sphere tool. A sphere object appears in the scene.
- 3 Squash and stretch the sphere, until it is the desired shape. Refer to [“Transforming Objects” on page 285](#) for more on transforming objects.
- 4 With the object selected, click the M icon that appears next to its bounding box. The Materials Lab appears.
- 5 Click the Volume button at the top of the lab.
- 6 Set up the values for channels in the material. Refer to [“Building Materials” on page 230](#) for more on creating materials.
 - Choose a cloud-like texture from texture components. Stratus, Cumulus or one of the CloudBump textures work well.

- Pay special attention to the Base Density channel as this sets the transparency of your fog.
- You need to set a high value for the Edge Softness channel to blur the edges of the sphere object.

- 7 Click the OK icon to exit the lab.
- 8 In the Working window, move the object to the area where you want the fog to appear.

Haze

Haze is the natural effect you see when a plane (like the ocean) stretches out towards the horizon. At this distant point a different color appears over the horizon and light becomes fuzzy.



Haze creates the illusion of a distant horizons. In this scene, the haze is used to create the distinction between the water plane and the sky.

The Haze control lets you set the intensity and color of the Haze effect in your Bryce scene.

If you are upgrading from Bryce 2, you may find that haze is more subtle at the lower end and you may need to adjust the Haze setting.

With haze set to zero, your horizon will have an unnaturally hard edge. Also note that the Cloud Altitude control will affect the height of this band of haze. The higher the altitude of the

atmosphere, the wider the band of haze at the horizon.



Haze=0



Haze=90

You can see how the haze changes in these skies as the Haze value changes.

Haze is applied to the entire scene equally. The haze always appears at the horizon.

To set Haze intensity:

- 1 Display the Sky & Fog palette by clicking the Sky & Fog button at the top of the Bryce window.
- 2 Drag horizontally inside the Haze thumbnail to increase or decrease the degree of haze in your scene. Drag to the left to decrease the amount of haze and to the right to increase it.

To set Haze intensity numerically:

- 1 If it's not already visible, display the Sky & Fog palette by clicking the button at the top of the Bryce window.
- 2 Click the Sky Lab button. The Sky Lab dialog appears.
- 3 Click the Atmosphere tab.
- 4 Click a field name then enter a value in the Haze Density, Thickness, and Base Height fields. These fields govern the amount of haze rendered into your scene. The range is 0 to 100%, and the default value is 4%.

Density controls density of the lower part of the atmosphere, and affects foreshadowing around the sun.

Thickness scales the whole atmosphere up or down, with the density at “sea level” remaining unchanged.

Base Height provides control over density at low altitudes, such as in valleys. It translates the entire atmospheric effect up or down without changing the density or thickness. In earlier versions of Bryce, you had to move the entire scene up or down relative to the atmosphere.

To set Haze color:

- 1 Display the Sky & Fog palette by clicking the Sky & Fog button at the top of the Bryce window.
- 2 Click the color swatch beneath the Haze thumbnail and choose a color from the color picker.

Fog and Haze colors should be the same, or almost the same. For realism, the haze should be a little brighter and bluer than the fog. At nighttime, you have less illumination, so an effective nocturnal haze color could be dark blue-gray.

Blending the Haze color with the Sun

Since the Haze always appears at the horizon it should change color as the sun sets or rises. The Blend with Sun feature lets you simulate this effect. When the two elements are linked, the haze color and brightness change

depending on the position of the sun. This creates very realistic looking sunsets.



In this example, the haze is linked to the sun. You can see how the color of the horizon changes as it gets closer to the sun.

When you're using this feature to create sunsets, you should choose the haze color carefully so as to create a natural-looking color scheme.

To link Haze to the Sun controls:

- 1 If it's not already visible, display the Sky & Fog palette by clicking the text item on the menu bar.
- 2 Click the Sky Lab button. The Sky Lab dialog appears.
- 3 Click the Atmosphere tab.
- 4 Click the Blend with Sun button.
- 5 Make sure the Blend Haze and Blend Fog buttons are enabled.
- 6 Enter a value in the Color field, or use the slider, to set how much of the haze color is blended with the sun.
- 7 Enter a value in the Luminance field, or use the slider, to set the intensity of the haze color when it's blended.

- 8 To get the best effect, set both these fields to 100.

Setting the Color Perspective

Color perspective is the change in color with distance that characterizes the appearance of distant scenes in Nature: Dark areas turn blue and light ones yellow to orange to red. In Bryce you can make things change any color you like with distance. Color perspective is half of aerial perspective, while the other half is the loss of contrast with distance.

Color perspective controls the rate at which the red, green and blue components of the atmosphere come in with distance. In Nature, the atmosphere is white or a pale shade of gray. The blue component of that shade comes in faster than the green, which in turn comes in faster than the red. This is because the Earth's atmosphere scatters blue light more efficiently than green, and red least efficiently of all. The net result is that as a dark area recedes into the distance, it will turn blue before it turns white or pale gray in the far distance. Similarly, white areas will turn yellow, then orange, then red with increasing distance. The default values of color perspective are very delicate: If you mess with them, expect bizarre results!

To set the color perspective:

- 1 If it's not already visible, display the Sky & Fog palette by clicking the text item on the menu bar.
- 2 Click the Sky Lab button. The Sky Lab dialog appears.
- 3 Click the Atmosphere tab.
- 4 Click the Color Perspective button.
- 5 Click RGB controls to control the rate at which the red, green, and blue

components of the atmosphere come in with distance.

Clouds in Bryce

There two kinds of clouds in Bryce: clouds in the environment and cloud planes.

Clouds you add to your sky interact with the light in your scene. They can block out the light of the sun and change the color of the light that hits the objects in the scene. These clouds are infinitely distant so you cannot fly through the clouds in the sky. If you want to have this effect, use a cloud plane. Sky clouds can also cast shadows on the ground below.



The clouds in this scene were created using Cumulus clouds from the Sky and Fog palette.

You can change the look of the clouds by editing the texture used to create it. By changing the texture you can alter the shape and position of the clouds within the sky.

Cloud planes are infinite planes that act as objects in your scene. They cast shadows and can interact with other objects.



The clouds in this scene were created using an infinite cloud plane. Using this type of cloud, you can fly an airplane through the layer.

Both types of clouds can be animated. The clouds in the sky can be animated by changing their color, position or frequency, and cloud planes can be animated just like other objects. They can also be animated using the Cloud Motion controls. These controls let you set parameters for automatically animating clouds.

Refer to “Animating Clouds” on page 394 for more on animating clouds.

Adding Clouds

The Sky & Fog palette provides several controls that set the attributes of clouds in your sky. The Cloud Coverage, Cloud Altitude, and Cloud Frequency and Amplitude controls let you set

the general appearance of your clouds. The Cloud Color sets the color of the clouds.

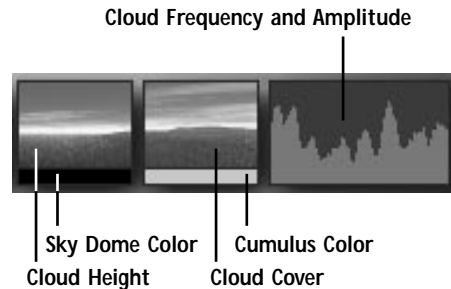

Use the cloud controls to set the attributes of the clouds in your scene.

You can add clouds to your scene in five easy steps:

- Select the type of cloud
- Adjust the cloud texture
- Set the cloud coverage and color
- Set cloud altitude
- Set the frequency and amplitude of clouds

Cloud Types

There are two types of clouds you can add to your Bryce environment: Cumulus and Stratus. Cumulus clouds are generally found at lower altitudes and appear thicker and fluffier.



The sky in this scene uses Cumulus clouds.

The Stratus appear at higher altitudes and appear thinner and more wispy.

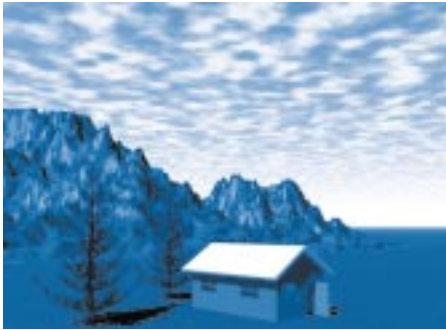

The sky in this scene uses Stratus clouds.

To add Cumulus clouds to a sky:

- 1 If it's not already visible, display the Sky & Fog palette by clicking the Sky & Fog button at the top of the Bryce window.
- 2 Click the triangle in the corner of the palette and choose Cumulus Clouds.
Cumulus clouds are thicker, darker clouds at a lower altitude. These clouds will take on tints of Sunlight color, Ambient color, or Cumulus color.

To add Stratus clouds to a sky:

- 1 If it's not already visible, display the Sky & Fog palette by clicking the Sky & Fog button at the top of the Bryce window.
- 2 Click the triangle in the corner of the palette and choose Stratus Clouds.
Stratus clouds are bright white, thin, clean clouds that appear at high altitudes. These clouds are very responsive to Sunlight color and Sky Dome color, and less responsive to Cumulus color or Ambient color.

You can also choose both cloud types, or neither. Selecting neither cloud type creates a clear sky.

Editing Cloud Textures

Clouds in Bryce are created using a procedural texture with a cloud pattern. The color, position, size, and pattern within the texture determines the final look of the cloud in your sky. You can edit this texture using either the Sky Lab palette, or for more complex editing, you can use the Texture Editor.

The texture used for a cloud can come from either the Bryce texture library or you can create your own.

To edit cloud texture in the Sky Lab dialog:

- 1 If it's not already visible, display the Sky & Fog palette by clicking the Sky & Fog button at the top of the Bryce window.
- 2 Click the Sky Lab button. The Sky Lab palette appears.
- 3 Click the Cloud Cover tab.



The Cloud Cover tab provides controls that let you edit the textures that are used to create the clouds in your scene. As you change a texture, the texture preview updates.

- 4 Click the + or - Turbulence buttons to increase or decrease the amount of noise in the texture.
 - Increasing the Turbulence creates a more dense pattern within the texture.
- 5 Click the + or - Complexity buttons to increase or decrease the amount of detail in the texture.
 - Increasing the Complexity increases the complexity of the patterns within the texture.
- 6 Click the Randomize button if you want to choose a randomly generated texture for your clouds.
- 7 Click the three buttons to the left of the selected cloud type to change the colors used in the clouds.
- 8 Click the Reset button to restore the original settings, if you want to start over.
- 9 Click the OK icon to apply your changes.

To edit cloud textures in the Deep Texture Editor:

- 1 If it's not already visible, display the Sky & Fog palette by clicking the Sky & Fog button at the top of the Bryce window.
- 2 Click the Sky Lab button. The Sky Lab palette appears.
- 3 Click the Cloud Cover tab.
- 4 Click the Edit button below the type of clouds you want to edit.
- 5 Click the Edit button. The Deep Texture Editor appears.
The cloud texture and its components appear in the component windows.

If you're not familiar with using the Deep Texture Editor you may get some very unpredictable results which may result in clouds that don't look much like clouds. Before you start editing the clouds texture you may want to refer to "Textures" on page 237 for more instruction on how to use the editor.

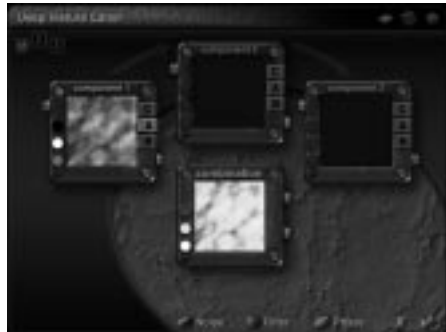

When you open a cloud texture in the texture editor, you can see its components in the various windows. You can use the editor's tools to completely redesign the texture or to alter the existing texture.

- 6 If you want to add additional turbulence to the cloud texture, adjust the texture's Noise:
 - Click the Noise button at the bottom of the editor. The Noise control appears.



The Noise control lets you adjust the frequency of the noise in any of the texture's components.

- Move the component indicator at the top of the control to the component you want to edit.
 - Adjust the Noise slider to increase/decrease the frequency of the noise in the texture.
- 7 If you want to change the colors of a component, click one of the color

indicators in the component window and choose a new color.

8 If you want to add more complexity to the texture, adjust its Phase:

- Click the Phase button at the bottom of the editor. The Phase control appears.



The Phase control lets you adjust the amplitude of the phase in any of the texture's components.

- Move the component indicator at the top of the control to the component you want to edit.
- Adjust the Phase slider to increase/decrease the amplitude of the phase.

9 If you want to change the pattern in the texture, apply a filter:

- Click the Filter button at the bottom of the editor. The Filtering control appears.

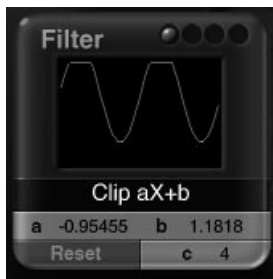

The Filtering control displays a graphical representation of the filter applied to your texture. By changing the equation of the filter to the value of the variables, you can change the patterns within the cloud texture.

- Move the component indicator at the top of the control to the component you want to edit.

- Change the filter equation and variable values to adjust the filter applied to your texture.

Filtering is a rather complex operation. Try experimenting with different equations and see what happens.

10 Click the OK icon to exit the editor.

Cloud Coverage

Cloud Coverage controls the quantity of clouds you can see in the sky. A high coverage means that there is a very dense cloud layer, and a low setting means that there are very few clouds in the sky.

Cloud coverage also indirectly controls the brightness of the environment. The more cloud coverage you have in a sky, the darker the environment, since less sunlight can pass through the clouds.

Adjusting cloud coverage changes the quantity of clouds but not the frequency. You can think of it as adjusting the volume on a radio without changing the station.

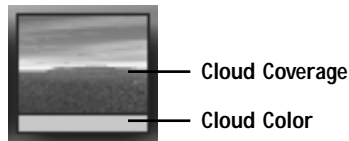

The Cloud Coverage control in the Sky & Fog palette lets you interactively set the quantity of clouds in the sky.



Cloud Coverage=10



Cloud Coverage=90

For example, you can see how the clouds change in these skies as the cloud coverage value changes.

To set cloud coverage:

- 1 If it's not already visible, display the Sky & Fog palette by clicking the Sky & Fog button at the top of the Bryce window.
- 2 Drag left or right inside the Cloud Coverage control thumbnail. Drag left to decrease coverage and right to increase it.

To set cloud coverage numerically:

- 1 If it's not already visible, display the Sky & Fog palette by clicking the Sky & Fog button at the top of the Bryce window.
- 2 Click the Sky Lab button. The Sky Lab dialog appears.
- 3 Click the Cloud Cover tab.
- 4 Drag the slider or enter a value in the Cloud Cover field.



The Cloud Cover setting controls the amount of clouds in your scene. The range is 0 to 100%, and the default value is 20%.

To set cloud color:

- 1 Display the Sky & Fog palette by clicking the Sky & Fog button.
- 2 Click the color swatch beneath the Cloud Coverage thumbnail and choose a color from the color picker.

Cloud Altitude

The altitude of your clouds has a great effect on the personality of your sky. Higher altitudes will result in smaller, more distant cloud formations, as well as a thicker band of haze at the horizon. Lower altitudes result in larger, more languorous cloud formations and a thinner band of haze at the horizon.



Cloud Altitude

The Cloud Altitude controls in the Sky & Fog palette lets you interactively set the height of the cloud layer in the sky.



Cloud Altitude=10



Cloud Altitude=90

For example, you can see how the clouds change in these skies as the cloud altitude value changes.

There are two things to remember when working with this control. First, the Cloud Altitude will affect the size of your Haze band, if you have a haze setting greater than zero. The higher the altitude, the wider the haze region will be on the horizon. You can use this interaction to your benefit.

Second, remember to lower your altitude setting if you are creating a nighttime scene. Since high altitudes increase the size of the horizon Haze region, the sky will be too unnaturally bright for realistic night scenes.

To set cloud altitude:

- 1 If it's not already visible, display the Sky & Fog palette by clicking the text item on the menu bar.
- 2 Drag horizontally inside the Cloud Altitude control thumbnail. Drag left to decrease altitude and right to increase it.

To set cloud altitude numerically:

- 1 Display the Sky & Fog palette by clicking the Sky & Fog text button.
- 2 Click the Sky Lab button. The Sky Lab dialog appears.
- 3 Click the Cloud Cover tab.
- 4 Drag the slider or enter a value in the Cloud Height field.

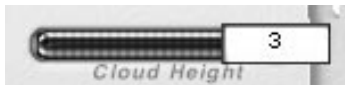

The Height field controls the height of the clouds in your scene. The range is 0 to 999, and the default value is 3.

Sky Dome Color

The Sky Dome color lets you create a color wash over your scenes, even if there is no sunlight present. This color simulates the natural effect that occurs when you have color in the sky even though the sun has set. Sky

dome color is a great way of creating late afternoon or evening scenes.

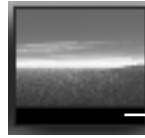

Sky Dome Color

The Sky Dome Color control in the Sky & Fog palette lets you choose a color from either the color picker or the color dialog.

For late afternoon and early evening realism, try using a touch of orange or yellow. This will create a cast of color over your entire scene, regardless of the position or color of the sun or moon.

To set Sky Dome color:

- 1 If it's not already visible, display the Sky & Fog palette by clicking the text item on the menu bar.
- 2 Click the color bar beneath the Cloud Altitude control thumbnail and choose a color from the color picker.

Frequency and Amplitude

The Frequency and Amplitude control lets you set the types of cloud formation you'll see in your sky. By combining these two controls you can change your clouds from light and fluffy to dark and brooding.



Use Frequency and Amplitude to control the types of cloud formations in your scene.

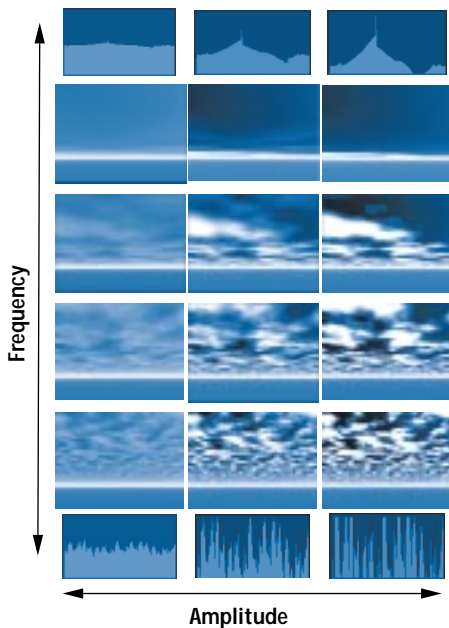

This graph shows the effects of different Frequency and Amplitude settings on a sky. Frequency values range from 2 at the top to 150 at the bottom. The Amplitude values range from 50 at the left to 500 on the right.

To set Cloud Frequency and Amplitude:

- 1 Display the Sky & Fog palette by clicking the Sky & Fog button at the top of the Bryce window.
- 2 In the Cloud Frequency and Amplitude control, drag horizontally to control the frequency of your cloud formations.
Drag left, and the “spikes” will get closer together, resulting in smaller formations. Drag right for larger, more luxurious formations.

The Text Display area shows you the numerical value of the amplitude as you drag.

- 3 Drag vertically to control the amplitude of your cloud formations.

Drag away from the horizontal center, and the spikes increase in height, resulting in formations with harder edges. Drag toward the horizontal center for softer-edged formations.

Note: It is possible to invert the spikes. This means that you can exchange positive and negative spaces in your sky. If you invert the amplitude, everything that was previously clear sky will be clouds, while everything that was cloud will be clear sky.

To set Frequency and Amplitude numerically:

- 1 If it's not already visible, display the Sky & Fog palette by clicking the text item on the menu bar.
- 2 Click the Sky Lab button. The Sky Lab dialog appears.
- 3 Click the Cloud Cover tab.
- 4 Drag the slider or enter a value in the Frequency field.



The Frequency field controls the frequency (scale) of cloud formations in your scene. The range is -200 to +200, and the default value is 25.

- 5 Drag the slider or enter a value in the Amplitude field.



The Amplitude field controls the amplitude (edge softness) of clouds in your scene. The range is -500 to +500, and the default value is 100.

Linking Clouds to the Camera View

If you move the camera view during an animation, the clouds in your environment will appear to zoom by, creating a kind of time-lapsed effect. If you want the clouds to appear fixed as you move the camera, link the cloud in the sky to the camera view. This way, wherever the camera moves the clouds will follow, so that they seem to remain stationary.

To link clouds to view:

- 1 If it's not already visible, display the Sky & Fog palette by clicking the text item on the menu bar.
- 2 Click the Sky Lab button. The Sky Lab dialog appears.
- 3 Click the Cloud Cover tab.
- 4 Click the Link Clouds to View button.
Refer to "Animating Skies" on page 393 for more on animating skies.

Using a Fixed Cloud Plane

As you move higher up in a Bryce environment, the cloud pattern shifts, so that it appears as if you're getting closer to the clouds. If you want to counter this effect, you can use the Fix Cloud Plane option to freeze the cloud pattern so that it doesn't change as you move higher up in the environment.

To use a fixed cloud pattern in your sky:

- 1 If it's not already visible, display the Sky & Fog palette by clicking the text item on the menu bar.
- 2 Click the Sky Lab button. The Sky Lab dialog appears.
- 3 Click the Cloud Cover tab.
- 4 Click the Fixed Cloud Plane button.

Setting the Cloud Motion

You can set the speed and turbulence of clouds as well as specify the direction of motion.

To set cloud speed:

- 1 If it's not already visible, display the Sky & Fog palette by clicking the text item on the menu bar.
- 2 Click the Sky Lab button. The Sky Lab dialog appears.
- 3 Click the Cloud Cover tab.
- 4 Drag the slider, or enter a number in the Speed field.

To set cloud turbulence:

- 1 If it's not already visible, display the Sky & Fog palette by clicking the text item on the menu bar.
- 2 Click the Sky Lab button. The Sky Lab dialog appears.
- 3 Click the Cloud Cover tab.
- 4 Drag the slider or enter a value in the Turbulence field.

To set the direction of motion:

- 1 If it's not already visible, display the Sky & Fog palette by clicking the text item on the menu bar.
- 2 Click the Sky Lab button. The Sky Lab dialog appears.
- 3 Click the Cloud Cover tab.
- 4 Drag the control to specify the angle of motion.

Working with the Sun

The sun is the source of all natural light in your scene. Its attributes have a profound effect on the look of your scene.

The color of the sun affects all the colors of all the objects in the scene; Sunlight color tints all the other visible colors.

The position of the sun controls the time of day in your scene. If the sun is above the horizon, it is day; if it is below, it is night, and if it is at the horizon, it is sunrise or sunset.

The sun can be animated just like all the other elements of your Bryce scene. You can create time-elapsd effects by changing the position of the sun over the course of an animation. Refer to “Animating Sun or Moon Position” on page 395 for more on animating the Sun.

Positioning the Sun

The sun position control sets the direction your natural light is coming from whether it is sunlight or moonlight. The position can be set using the Sun control in the Sky & Fog palette. The control works like a trackball, with the sun at one end and the moon at the other.

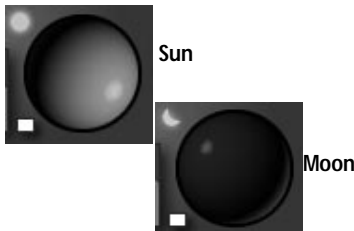

The control works like a trackball. As you drag over the control both elements move in the direction you drag.

You can think of the control as a compass: if the highlight on the Sun Control sphere is

positioned at 12 o'clock, the light comes from the north, and so on.

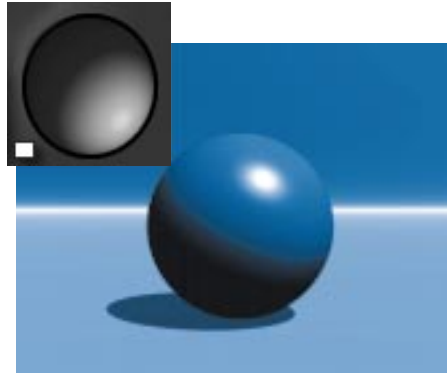

As you change the position of the sun, the “time of day” changes. When the sun position is closer to the edges of the control, the sun appears closer to the horizon, making the scene darker.

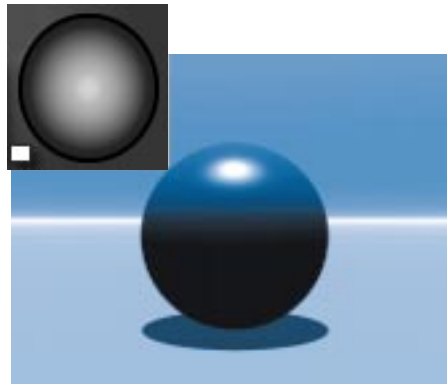

When the sun is in the center of the control, the sun shines from directly above the sun, like it would at high noon.

The colors in your sky will change depending on the position of the Sun Control, or the “time of day...” just like in the real world.

The angle of the shadows changes as the sun changes. If your object is shiny, and there are

no other light sources, the position of the sun controls where the highlight appears.



In this example, you can see the effects of the sun's position on several reflective and shiny objects.

Day and Night

Your sky always contains two heavenly bodies: the sun and the moon. There is always one body visible in your sky. At night it is the moon and in the day its the sun.

The two bodies are connected and always remain at opposite ends of the sky. As you move the sun you're also moving the moon. This means that when the sun dips below the horizon in front of you, the moon is rising behind you.



The link between the sun and the moon can be seen by positioning the sun at the horizon in front of the camera...



.if you turn the camera 180° you'll see the moon just rising over the horizon as well.

To switch between night and day:

- 1 Display the Sky & Fog palette.
- 2 Click the Day/Night toggle button in the top-left corner of the sun position controls.

Sunrise/Sunset

You can create a sunset or sunrise by positioning the sun or moon so that it is visible on your horizon.



Sunsets or sunrises can be created by moving the sun closer to the horizon.

The colors in the sky automatically change to create the illusion of the sunrise or sunset colors. You can also use the Sky Dome color to give your sunset/sunrise added color.

For a more realistic sunset you may want to link the fog and haze to the sun so that they react to the sun color as it approaches the horizon. Refer to “Blending the Fog Color” on page 132 and “Blending the Haze color with the Sun” on page 135 for more on this feature.

You may also want to enable the Horizon illusion for the sun. This feature makes the sun appear larger as it approaches the horizon. Refer to “Sun/Moon Horizon Illusion” on page 152 for more on this effect.

To position the sun manually:

- 1 Display the Sky & Fog palette by clicking the Sky & Fog button at the top of the Bryce window.
- 2 Drag the larger highlight area in the Sun Position controls to the position where you want the light to originate.

You can position the sun, or the moon, on the horizon as you like by nudging the Sun Control until the light is visible in your scene.

To position the sun numerically:

- 1 Display the Sky & Fog palette by clicking the Sky & Fog button at the top of the Bryce window.
- 2 Click the Sky Lab button. The Sky Lab palette appears
- 3 Click the Sun & Moon tab.
- 4 In the Numeric Sun Values fields, type a value into the Azimuth field. The Azimuth field controls the east-to-west position of

the sun. The range is 0 to +360, and the default value is in the range of 0 to 90.

- 5 Enter a value in to the Altitude field. The Y field controls the height of the sun relative to your scene. The range is -99 to +99, and the default value is 20.

Positive values are above the horizon, negative values below.

Linking the Sun to the Camera

Normally, you’d have to reposition the sun every time you changed the camera to maintain a certain effect or sunlight angle. However, if you apply the Link Sun to Camera, you’re sun will track the camera. The position of the sun relative to the camera remains the same no matter where the camera is positioned. This way you can set up the sun position once and then not worry about losing the effect as you move the camera.

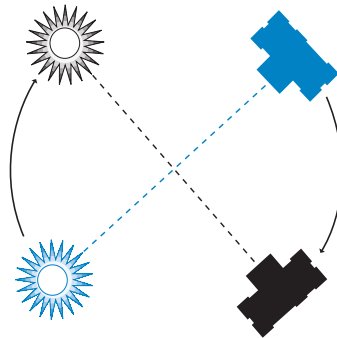

When the sun is linked to the camera, the sun moves relative to the Camera. Wherever the camera moves the sun follows. As it moves, the sun maintains a constant distance from the camera.

This feature can also be very useful when you’re animating your scene. Refer to “Animating” on page 353 for more.

To link the sun to the camera:

- 1 Display the Sky & Fog palette by clicking the Sky & Fog text button.
- 2 Click the Sky Lab button. The Sky Lab palette appears.
- 3 Click the Sun & Moon tab.
- 4 Click the Link Sun to View button.

When this option is enabled, your sun will always remain in the same position relative to the camera. Wherever you move the camera the sun will follow. This is an easy way of seeing how a sunset will look against different skylines.

Sun Color

Light in nature is not usually visible until it strikes an object. When you're using normal light, a purple sunlight color will not paint your entire sky purple, but objects in your scene will reflect purple.

When you're using Visible World, choosing purple will paint your entire scene purple.

The grayscale bar at the bottom of the color palette lets you set the intensity of the sun. Black turns the sun off and white sets the sun to its brightest intensity.



You can also use the color palette to set the intensity of the sun. Black represents the lowest intensity and white the highest.

To set the Sun Color:

- 1 Display the Sky & Fog palette by clicking the Sky & Fog text button.
- 2 Click the Sun Color swatch and choose a color from the color picker.

Disabling the Sun

You can also remove the sun from the sky altogether, by disabling it. When the sun is disabled, the only light visible in your scene comes from individual light sources. (The scene will still be illuminated.)

To disable the Sun:

- 1 Display the Sky & Fog palette by clicking the Sky & Fog text button.
- 2 Click the Sky Lab button. The Sky Lab palette appears
- 3 Click the Sun & Moon tab.
- 4 Click the Disable Sun Light button.

Working with the Moon

The moon is the most prominent object in the night sky. In a night scene it provides all the natural light in the environment. Like the sun, the moon's attributes can greatly affect the final look of your scene.

Its position in the sky effects all the angles and intensities of all the shadows in the scene.

The brightness is affected by the illumination reflected off the earth. The brighter the earthshine, the brighter the moon appears.

Unlike the sun, the moon has phases which simulate the effects of the earth's shadow

passing over the face of the moon during a month.

The moon's position and phases can be animated using the Animation controls and the timeline. Refer to "Animating Sun or Moon Position" on page 395 for more on animating the moon.

Positioning the Moon

The moon is positioned at the same time as the Sun. The two are always at opposite ends of the sky, so wherever the sun is positioned, the moon is directly opposite.

In the Sun/Moon control on the Sky & Fog palette, the moon's position is represented by the smaller highlight portion of the Sun Position trackball.

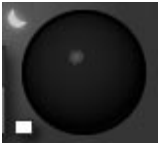

The position of the moon is represented by the smaller highlight portion of the position control trackball. You can position the moon by either moving the smaller highlight or by dragging the sun. The moon is always opposite the sun.

To position the moon manually:

- 1 Display the Sky & Fog palette by clicking the Sky & Fog button at the top of the Bryce window.
- 2 Drag the blue highlight area in the Sun/Moon Position controls to the position where you want the light to originate.

You can position the sun, or the moon, on the horizon as you like by nudging the Sun/Moon control until the light is visible in your scene.

To position the moon numerically:

- 1 Display the Sky & Fog palette by clicking the Sky & Fog button at the top of the Bryce window.
- 2 Click the Sky Lab button. The Sky Lab palette appears
- 3 Click the Sun & Moon tab.
- 4 In the Numerical Sun Values fields, type a value into the Azimuth field. The Azimuth field controls the east-to-west position of the sun/moon. The range is 0 to +360, and the default value is 60.
 - The moon will be positioned exactly opposite these values, so you can invert them to position the moon numerically, or place the Sun behind the camera so that the moon appears in front of it.
- 5 Enter a value into the Altitude field. The Altitude field controls the height of the sun/moon relative to your scene. The range is -99 to +99, and the default value is 20.

Positive values are above the horizon, negative values below.

Moon Phases

The moon phases control simulates different aspects of the moon as it orbits the earth.



The change in the phases of the moon can indicate the passage of time.

The moon phase is a visual clue to the time of the month. In an animation, you can use the moon phase to simulate the passage of a time. Refer to “Animating Sky & Fog settings” on page 393 for more.

The phase is controlled using the Moon Phase controls in the Sky Lab palette.

To set the moon's phase:

- 1 Display the Sky & Fog palette by clicking the Sky & Fog button at the top of the Bryce window.
- 2 Click the Sky Lab button. The Sky Lab dialog appears.
- 3 Click the Sun & Moon tab.

- 4 Drag over the Moon Phase control. The phase changes as you drag.

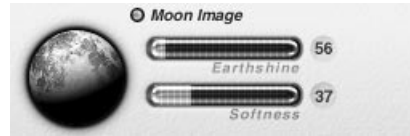

The Moon Phase control lets you set the phases of the moon.

- 5 Click the OK icon to exit the dialog.

Moon Brightness and Sharpness

The moon is directly affected by the light reflected from the earth. The brighter the reflection, the brighter the moon's shadow. In Bryce this effect is controlled by the Earthshine setting which makes the moon brighter or darker.

A realistic moon does not have sharp edges and may appear blurry on hazy nights. The Softness control lets you set the moon's edge softness to give a more realistic feel.

To set the brightness of the moon's shadow:

- 1 Display the Sky & Fog palette by clicking the Sky & Fog button at the top of the Bryce window.
- 2 Click the Sky Lab button. The Sky Lab dialog appears.
- 3 Click the Sun & Moon tab.
- 4 Drag the Earthshine slider. Drag left to increase the brightness and right to decrease it.



The Earthshine control lets you adjust the brightness of the moon.

- Enter a value in the Earthshine field to set Earthshine numerically.

5 Click the OK icon to exit the dialog.

To set the moon's edge softness:

- 1 Display the Sky & Fog palette by clicking the Sky & Fog button at the top of the Bryce window.
- 2 Click the Sky Lab button. The Sky Lab dialog appears.
- 3 Click the Sun & Moon tab.
- 4 Drag over the Softness control. Drag left to soften edges, or right to sharpen them.



The Softness control lets you set the edge softness of the moon.

- Enter a value in the Softness field to set Softness numerically.

5 Click the OK icon to exit the palette.

Adding Environmental Effects

The elements in a sky aren't constant; it is always changing, reflecting weather patterns or the time of day. If it rains there's a rainbow. If it's night, there's stars. If it's sunset, the sun looks bigger. If you look right at the sun on a hazy day you'll see rings around it. Sometimes, if it's hazy enough you can even see the sunlight streaking out of the clouds. All these illusions are called environmental effects and Bryce's Sky Lab palette contains all the controls you'll need to add them to your scene.

Sun/Moon Rings

If you look directly at the sun on a hazy day you'll be able to see rings surrounding it. These rings are created by the reflection off ice particles in the air. In Bryce, you can use the Sun/Moon Rings to create this effect.



In this example, rings have been added to the sun to make the scene look like a sweltering desert.

This effect creates concentric circles around the image of the sun or moon. Using the Sky Lab palette, you can set the radius of the rings and add a secondary ring to increase the effect. The color of the rings is controlled by the color of the sun/moon.

To add Sun/Moon rings:

- 1 Display the Sky & Fog palette by clicking the Sky & Fog button at the top of the Bryce window.
- 2 Click the Sky Lab button. The Sky Lab dialog appears.
- 3 Click the Sun & Moon tab.
- 4 Click the Halo Rings button.

- 5 In the Rings area, enter a value in the Intensity field, or drag the slider, to set the brightness of the ring.



The Intensity field next to the rings preview sets the brightness of the rings.

- 6 Enter a value in the Radius field, or drag the slider, to set the radius of the ring.



The Radius field next to the Rings preview sets the radius of the ring.

To add a secondary Sun/Moon ring:

- 1 Display the Sky & Fog palette by clicking the Sky & Fog button at the top of the Bryce window.
- 2 Click the Sky Lab button. The Sky Lab palette appears.
- 3 Click the Sun & Moon tab.
- 4 Click the Secondary Ring button in the Halo Rings area.

Sun/Moon Horizon Illusion

If you've ever watched a sunset, you probably noticed that the sun appeared to get larger as it approached the horizon. The same is true for the moon. At certain times of the month it appears huge. This illusion can be simulated using Sun/Moon size.



The spooky look of this night scene was created by applying a Horizon Illusion.

When the illusion is active, the sun or moon will appear to grow larger as it approaches the horizon.

To change the size of the Sun or Moon as it approaches the horizon:

- 1 Display the Sky & Fog palette by clicking the Sky & Fog button at the top of the Bryce window.
- 2 Click the Sky Lab button. The Sky Lab palette appears.
- 3 Click the Sun & Moon tab.
- 4 Click the Sun/Moon size button at the top of the dialog.
- 5 In the Sun/Moon size area, enter a value in the Disk Size field, or drag the slider, to set the overall size of the sun/moon anywhere in the sky.

- Enter a value in the Horizon Illusion field, or drag the slider, to set multiplier used to determine how much larger the sun or moon gets as it approaches the horizon.

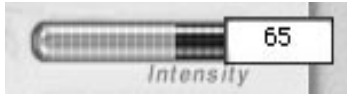

The Intensity field next to the Rings preview sets the width of the illusion.

Rainbows

In the real world rainbows appear after rainstorms as arcs of light displaying all the color in the spectrum. In Bryce a rainbow is an atmospheric effect that can be added to any sky.

A rainbow is only visible if the sun is visible, meaning you can't have a rainbow at night. As well, you can add a secondary rainbow to create the illusion of reflection.

Rainbows are linked to the sun so that as the color or intensity of the sun changes, so does the rainbow.

Rainbows are infinitely distant. You can't approach them by moving the camera, so the pot of gold is always just out of reach.

To add a rainbow to your sky:

- Display the Sky & Fog palette by clicking the Sky & Fog button at the top of the Bryce window.
- Click the Sky Lab button. The Sky Lab dialog appears.
- Click the Atmosphere tab.



The Atmosphere tab of the Sky Lab dialog contains all the controls you'll need to create rainbows.

- Click the Rainbows button to activate the rainbow controls.
- Drag the slider or enter a value in Radius field in the Rainbow area. This value sets the width of the rainbow.
- Drag the slider or enter a value in the Opacity field. This controls the rainbow's transparency.

To add a secondary rainbow to your sky:

- Display the Sky & Fog palette by clicking the Sky & Fog button at the top of the Bryce window.
- Click the Sky Lab button. The Sky Lab palette appears.
- Click the Atmosphere tab.
- Click the Secondary Rainbow button.
- Enter a value in Intensity field in the Rainbow area. This value sets the width of the secondary rainbow.

Star Fields

Stars in Bryce are randomly generated star maps. They are infinitely distant so they do not get closer as you move the camera. Star Fields are affected by the moon's brightness and color.

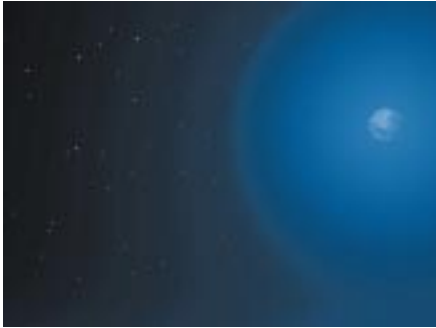

In this example you can see how the moon affects the color and intensity of the stars around it.

You can also add comets to your Star Fields. Comets appear at random positions. You'll usually only get one or two comets per starfield.

To add a Star Field:

- 1 Display the Sky & Fog palette by clicking the Sky & Fog button at the top of the Bryce window.
- 2 Click the Sky Lab button. The Sky Lab palette appears.
- 3 Click the Sun & Moon tab.
- 4 Click the Starfield button at the bottom of the palette.

To add comets to a Star Field:

- 1 Display the Sky & Fog palette by clicking the Sky & Fog button at the top of the Bryce window.

- 2 Click the Sky Lab button. The Sky Lab palette appears.
- 3 Click the Sun & Moon tab.
- 4 Click the Comets button at the bottom of the palette.

Volumetric World

The Volumetric World effect simulates the effects of particles in the air being illuminated by light sources. In Bryce this effect turns all the light sources in your scene into visible light sources. Sunlight also becomes visible, so that any color you applied to the sun appears everywhere in the scene.



Normal Environment



Volumetric World

In this example you can see how the Volumetric World effect transforms a scene.

Visible sunlight is volumetric, meaning that it is affected by all the objects within it.

Although Volumetric World is a very beautiful effect, its also a time consuming one. It will add considerably to your scene's rendering time.

To add visible sunlight to your scene:

- 1 Display the Sky & Fog palette by clicking the Sky & Fog button at the top of the Bryce window.
- 2 Click the Sky Lab button. The Sky Lab palette appears.
- 3 Click the Atmosphere tab.
- 4 Click the Volumetric World button.
- 5 Drag the slider or enter a value in the Quality field. This corresponds to the Rough or Fine button in the Visible Light area in earlier versions of Bryce. This option controls the quality of the light.

Using the Preset Skies Library

The Preset Skies Library contains all the preset skies available in Bryce. You can place them in your scene and edit them just as you would another object.

To add a sky from the Preset Skies library to your scene:

- 1 Click the triangle icon next to the Sky & Fog text button at the top of the Bryce window, or click the arrow next to

the preview area in the Sky Lab dialog. The Preset Skies Library appears.

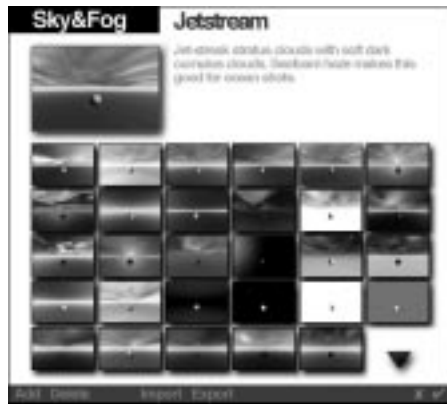

Use the Preset Skies Library to add pre-made skies to your scene.

- 2 Click on the preset thumbnails to view preset names and descriptions.
- 3 Click the OK icon to add the selected sky to your scene.

The Sky & Fog palette does not need to be active for you to access the Preset Skies Library.

You can select presets in one motion by dragging directly to the desired preset, and releasing the mouse button. You can also drag over the category names to change categories, into the category's presets, and then release the mouse button.

Adding and Deleting Preset Skies

You can add the sky from any open scene to the Preset Skies Library. This is a good way of saving your favorite skies.

To add a sky to the preset library:

- 1 Click the triangle icon next to the Sky & Fog text button at the top of the Bryce environment. The sky from your scene appears in the preview area of The Preset Skies Library dialog.

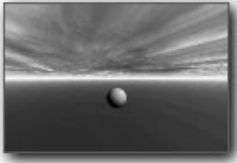

The preview area displays the sky from your scene.

- 2 Click the Add button at the bottom of the dialog. The Add Object dialog appears.
 - 3 Enter a name for the new preset in the Preset Name field.
 - 4 Enter a description of the preset in the Description field and click the OK icon. This name and description will appear beneath the object preview whenever the preset is accessed.
- You can edit the name and description of any preset at any time simply by pressing the Tab key, or clicking on the name or description.*
- 5 Click the OK icon. Your preset will be added to the first available space within the current category.

To delete an object preset:

- 1 Click the triangle icon next to the Sky & Fog text button at the top of the Bryce environment. The Preset Skies Library appears.
- 2 Click on the preset you want to delete, or hold down Shift and select a continuous series of presets, or hold down Command/

Ctrl and select a discontinuous set of presets.

- 3 Click the Delete button at the bottom of the Preset Skies Library dialog.

Importing and Exporting Preset Skies

Importing and exporting presets is a handy way to exchange custom presets with other users.

To import a preset sky file:

- 1 Click the triangle icon next to the Sky & Fog text button at the top of the Bryce environment. The Preset Skies Library appears.
- 2 Click the Import button at the bottom of the Preset Skies Library dialog. The file open dialog appears.
- 3 Locate the file which you would like to import and click Import. The contents of the file are placed into the first available space in the current category.

To export a preset sky file:

- 1 Click the triangle icon next to the Sky & Fog text button at the top of the Bryce environment. The Preset Skies Library appears.
- 2 Select the preset or presets you wish to export.
- 3 Click the Export button at the bottom of the Preset Skies Library dialog. The save file dialog appears.
- 4 Enter a name and location for the file and click Save.

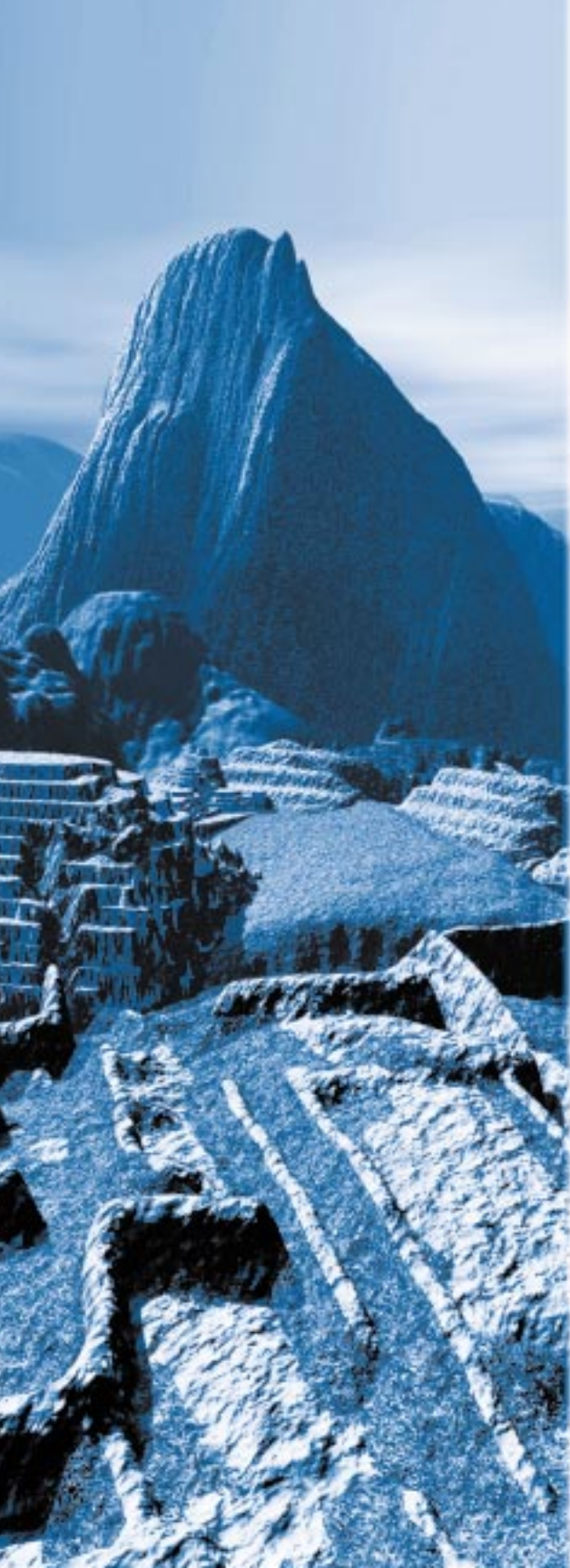

8

Terrains

What is a Terrain?

Terrain objects define the landscape of your scene. They represent the land forms of any scene: mountains, deserts, islands or even floating cities. In Bryce, a terrain object is a height map, which determines the shape of your landscape. You can make subtle adjustments to the map that can result in new mountain ranges or river beds.

Bryce creates a terrain's shape by converting brightness values in grayscale images into a height map. White areas in the image result in the highest altitudes and black areas result in the lowest. The Terrain Editor lets you generate the grayscale images that are used to create terrain objects.

Creating terrains in the Terrain Editor is a two-step process. First, generate the source of your terrain image by using the preset effects, painting an image using the paintbrush or importing a picture. Then, filter the image. The editor's Filtering tools let you fine-tune the grayscale values in your terrain.

You can also animate the creation of a terrain. Using the Animation controls available at the

bottom of the editor, you can change the shape of your terrain object over time. You can animate the formation of mountains and valleys, or the gradual destruction of the landscape.

The Terrain Editor

The Terrain Editor can be used to generate the grayscale image that is converted into a terrain object. It can also be used to edit an existing terrain.

You cannot access the Terrain Editor unless you have a terrain object in your scene. When the editor opens, it temporarily replaces the screen and displays the current terrain as a three dimensional preview. The height map that was used to create the terrain is displayed in the Terrain Canvas.

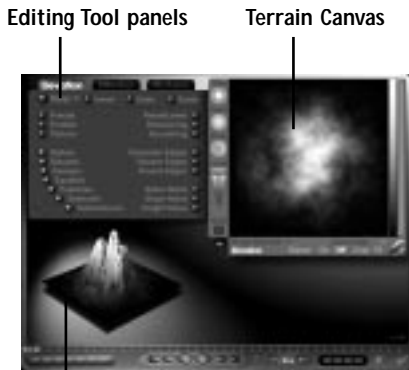

3D Terrain Preview

When you access the Terrain Editor, it temporarily takes over your screen.

To add a terrain object to your scene:

- 1 Click the Create text button at the top of the Bryce environment. The Create palette appears.

- 2 Click the terrain object tool. A randomly generated terrain appears in your scene.



Once you have a terrain object you can customize it in the editor.

To open the Terrain Editor:

- 1 Select the terrain object.
- 2 Click the E icon that appears next to the terrain object,

or choose **Objects menu>Edit Object**,

or click the Edit text button and then click the Edit Terrain tool,



or press Command-E/Ctrl+E.

Features of the Terrain Editor

The Terrain Editor is divided into four sections:

- The Editing tools, which let you generate and edit the terrain's height map
- The Terrain Canvas, which displays the grayscale image used as a height map
- The 3D Terrain Preview, which displays a three-dimensional preview of the terrain you're working on
- The Animation controls, which let you set up key frames for animating the terrain

Editing Tools

Terrain tools are divided into three tabs that contain tools for generating terrain elevations, filtering terrains, and importing pictures to use as terrains:

- **Elevation** contains tools for generating terrains, and applying effects.
- **Filtering** contains tools for fine-tuning the gray levels in your terrain Canvas.
- **Pictures** contains tools for importing a picture to use as a Terrain Canvas.



The Terrain Editor tools are divided into three tabs.

To access a tab:

- Click the tab label. The tab tools move to the front. By default, the Elevation tools are in front.

Setting Terrain Options

The 3D Terrain area has several options that control how the preview updates and displays.

To set 3D Terrain options:

- Click the triangle icon in the bottom left corner of the Terrain Canvas frame and choose an option from the menu:
 - Auto Rotate** sets the 3D Preview to rotate perpetually. All changes update the 3D preview as it turns.
 - Realtime Linking** connects all terrain editing to the 3D Terrain Preview. Every analog change you make is applied simultaneously to the Terrain Canvas and the 3D preview.

RIP To Screen displays a full-screen preview of your terrain. Clicking anywhere will return you to the main Terrain Editor. Use Command-W/Ctrl+W to toggle in and out of this mode.

Visible Brush lets you turn the circle of the brush on and off.

Turn Terrain Solid applies volumetric materials to the terrain. Even if you are not using volume materials, this selection causes the material to render as a solid.

Smooth allows a smooth rendering of the terrain. If this is not selected, the terrain is faceted.

Keep Gradient makes the gradient the terrain's diffuse color.

Terrain Canvas

The Terrain Canvas displays the grayscale image that is used to create the terrain object. You can think of the Terrain Canvas as a top view of the terrain object you're creating.

The Terrain Canvas is where you paint the height map for your terrain. The image in the center of this area is the canvas. Around the canvas are the painting tools and zoom area controls.

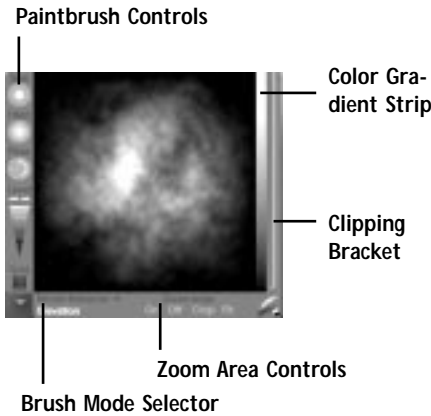

Brush Mode Selector
The Terrain Canvas displays the grayscale image that is used to create your terrain.

The main tools in this area are the grayscale paintbrush and the height picker. The paintbrush lets you paint images using different shades of gray. The Height Picker lets you pick up gray levels from other parts of your image to set the gray level of the paintbrush.

The left side of the frame includes all the paintbrush controls (Size, Hardness, Flow, and Level) as well as the Grid selector, which controls the resolution of the grayscale data.

The right side contains a gradient strip and bracket for clipping operations and controls for color mapping.

The bottom part of the frame includes a Brush Mode selector and Zoom Area controls.

3D Terrain Preview

The 3D Terrain Preview in the lower left corner of your screen displays the resulting terrain object based on the image in the Terrain Canvas.

As you edit the terrain image, the preview updates to show the result of your changes.

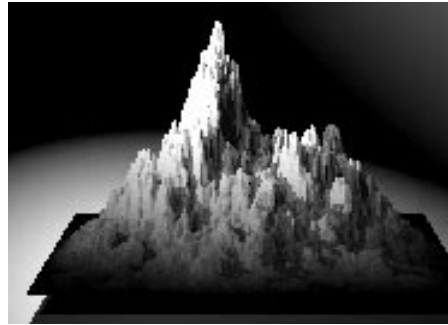

The 3D Terrain Preview shows the terrain object that will be produced from the image in the Terrain Canvas.

The preview of your terrain can be rotated so you can see your terrain object from different angles.

To rotate the terrain preview:

- Click and drag the preview object in the direction you want to rotate the terrain.

Animation Controls

The Animation controls at the bottom of the editor let you create key frames for your terrain. Any change you make to the geometry of the terrain can be stored in a key frame and animated.

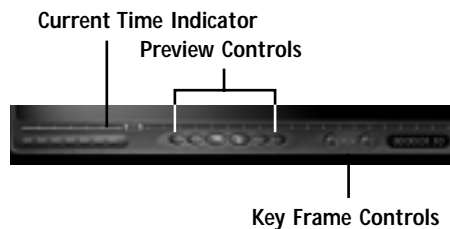

The Animation controls let you create key frames for the terrain so you can animate the terrain editing process.

The Timeline that runs along the bottom of the editor displays the length of the animation. The Current Time Indicator within the timeline lets you set the current time of the animation.

The buttons in the Animation controls let you preview the animation. The buttons beside the preview controls let you add and delete key frames from the Timeline.

Working in the Terrain Editor

Using Terrain Editor Tools

Most of the tools in the Terrain Editor are displayed as control dots. These dots let you apply an effect or operation to the terrain gradually or at 100%.

To apply a tool to the Terrain Canvas:

- 1 Move the cursor over the tool you want to use.
- 2 Do one of the following:
 - To apply an effect or operation entirely, click the control dot just once.
 - To apply an effect gradually, click and drag over the control dot.
 - Apply an effect by clicking a tool more than once. The effect is applied in 100% increments.

Starting a New Terrain

By default when you open the Terrain Editor, the terrain you selected in the Working window appears in the Terrain Canvas. If you want to begin with a new, flat Terrain Canvas, use the New button.

To create a new Terrain Canvas:

- 1 Make sure the Elevation tab is displayed. If it's not, click the Elevation title.
- 2 Click the New button.
or press Command-N/Ctrl+N.
A flat black image appears in the Terrain Canvas.

To gradually flatten your terrain:

- Click and drag to the right over the New button.
The existing Terrain Canvas gradually fades to black.

Many of the effects in the Elevation tab require grayscale values. If you apply these effects to a black map they may have no effect. Try to use this only when you're setting up for brushing operations.

To reset your terrain:

- Hold down Control and click the New button.
The Terrain Canvas is reset to the terrain that appeared when you first opened the editor.

Inverting Terrains

Since the Terrain Editor uses brightness to determine altitude, you can change mountains into canyons by inverting the black and white values in your image.

To invert your terrain image:

- 1 Make sure the Elevation tab is displayed. If it's not, click the Elevation title.

- 2 Click the Invert button, or press Command-I/Ctrl+I.

All the black areas of your image become white and white areas become black.

To gradually invert your terrain image:

- Click and drag to the right over the Invert button.

The black areas in the existing Terrain Canvas progressively turn white.

Undoing Operations

You can reverse any effect you apply to your image using the **Undo** button. You can toggle between Undo and Redo by clicking the Undo button repeatedly.

To undo operations in the Terrain Editor:

- 1 Make sure the Elevation tab is displayed. If it's not click the Elevation title.
- 2 Click the Undo button, or press Command-Z/Ctrl+Z

The last operation you applied is undone.

Eroding Terrains

Erosion simulates the effects of water erosion on your terrain objects. The calculations in this effect simulate droplets of water falling on your terrain, and then calculate where the droplets would trickle based on the shades of gray progressing towards black. This effect works best on maps that have large sloping areas.

The Erode button simulates the effects of erosion over a short period of time, like decades.

To simulate the effects of centuries of erosion, use the Eroded tool.

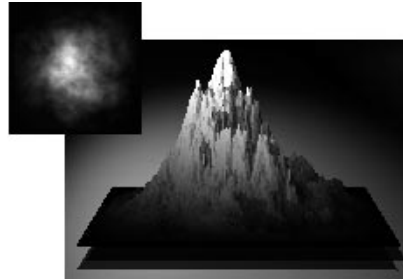

This is what a terrain looks like before you apply the Erode effect. Notice that this image map has sloping areas that will make the erode effect more visible.

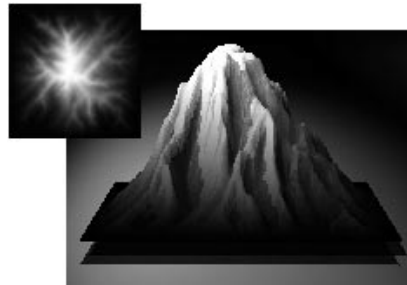

This is the same terrain after the Erode effect is applied. You can see how the surface now contains tracks created by running water.

To erode terrains:

- 1 Make sure the Elevation tab is displayed. If it's not, click the Elevation title.
- 2 Click the Erode button. To gradually apply erosion, hold down the mouse button and drag while the pointer is over the Erode button.

Using the Zoom Area

When the Zoom Area is active, only a small portion of your terrain is displayed in the 3D Terrain Preview. The 3D Terrain Preview dis-

plays the zoomed-in portion of your Terrain Canvas. You can use this feature to see small variations in the surface of your terrain. The Zoom Area can be moved to any point on your Terrain Canvas.

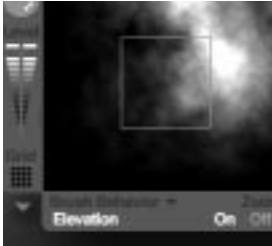

Use the Zoom Area to see a close up of an area in your Terrain Canvas in 3D.

You can always paint while the Zoom Area is active; in fact this is a nice way to paint in the Terrain Canvas while previewing a small section in 3D to observe details.

To turn the Zoom Area on:

- Click the On text button below the Zoom Area title at the bottom of the Terrain Canvas frame.
A marquee appears on your Terrain Canvas.

To turn the Zoom Area off:

- Click the Off text button below the Zoom Area title at the bottom of the Terrain Canvas frame.

To move the Zoom area:

- 1 Move your pointer over an edge of the Zoom Area marquee. The pointer changes to a hand tool.
- 2 Drag the marquee to an area in the Terrain Canvas.

To resize the Zoom area:

- 1 Move the pointer over a corner of the Zoom Area marquee.
- 2 Drag away from the center of the marquee to enlarge the Zoom Area, or towards the center to shrink the area.

To scale the zoom area to fill the Terrain Canvas:

- Click the Crop text button below the Zoom Area title at the bottom of the Terrain Canvas frame.
The contents of your Zoom Area are scaled to fill the entire Terrain Canvas area. The Zoom Area contents replace the existing contents of the Terrain Canvas.

This feature can be useful for creating new terrains from larger high-resolution terrains.

To fit the contents of the Terrain Canvas into the Zoom Area:

- Click the Fit text button below the Zoom Area title at the bottom of the Terrain Canvas frame.

The entire contents of your Terrain Canvas are scaled down to fit into the Zoom Area marquee. The rest of the Terrain Canvas will be filled with black.

Setting Terrain Resolution

The terrain's resolution determines the amount of detail in your terrain. The higher the resolution, the more detail appears in your terrain's surface. However, higher resolution values also increase the rendering time for your scene and require more memory.

The default resolution is 128. The highest resolutions should be reserved for terrains that are very close to your camera and for any other case where detail is important. For items that are far away, or where detail is not so important, lower resolutions are more appropriate.

Brush sizes may appear to vary depending on your resolution, but in fact they remain proportional to the size of the Terrain Canvas. The Terrain Canvas is always displayed at 256x256. So, if you change the resolution to 1024x1024, the Terrain Canvas will still appear in that 256x256 window and, in order to remain proportional, brushes will appear smaller.

To set the Terrain resolution:

- Click the Grid icon on the left side of the Terrain Canvas frame and choose a resolution from the menu.

The resolutions available are:

- 16 very coarse
- 32 coarse
- 64 simple
- 128 normal
- 256 fine
- 512 ultra fine
- 1024 massive resolution

Creating Terrains

You can create terrains in several ways. You can let the editor do all the work of generating a terrain based on a series of algorithms, you can use the editor's painting tools to create a custom image, or you can import an image into the editor.

When you generate a terrain, you use the Terrain Editor's Elevation tools, which include

erosion effects as well as dozens of other effects optimized for the purpose of heightening realism in Bryce terrains.

When you paint a terrain you use the editor's grayscale paintbrush to paint a topographical image. The image is then converted to a terrain object.

You can also create a terrain by importing a picture into the editor. The picture is converted to grayscale which is then used to generate altitude values.

Creating Landscapes

When you're planning the shape of your terrain you should keep in mind the kind of landscape you want to create. You don't have to create all the land in your scene as a single terrain. More complex landscapes can be created by combining several terrain objects.

Before creating terrain objects, plan out the entire map of your landscape. Then you'll be able to see where different terrain objects might be combined to create a single land mass.

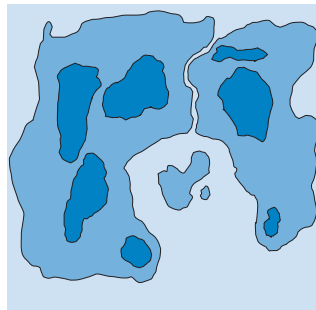

Before you start creating terrains you should map out all the land masses in your environment...



...then you'll be able to see where you will need to combine more than one terrain to create a specific type of landscape.

If you have more terrains in your scene, you'll have a bigger scale for the environment. This gives you more resolution and better atmosphere effects.

Pay attention to where the camera is positioned in the scene. Terrains that are closer to the camera need to be more detailed than those off in the distance.

Animation and Terrain Editing

You can record the process of creating a terrain into an animation using the Animation controls. Refer to "Animating" on page 353 for more on animating. Some of the Elevation tools can produce some unpredictable results when they're animated, so you may want to experiment with animating elevations before you create your final terrain.

Elevation Tools

The Elevation tools are preset effects that apply different calculations to your Terrain Canvas. The tools are divided into three categories on the tab: Source Generator, Basic Tools and Special Effects.

Source Generators create basic terrain surfaces. The Basic Tools edit the overall shape of your terrain, and Special Effects add realism to your terrain's surface.

You can create a terrain by combining effects. For example, you can start off creating a basic terrain using the Fractal tool, then create realistic ridges by applying the Erode tool. From there you can fine-tune your terrain by applying Spikes, creating Mounds or adding Cross Ridges. Finally, you can define the basic shape of your terrain by blurring the edges.

Using Elevation Tools

Along the bottom left corner of the Elevation tab are an orange and green curve of dots. The orange curve contains tools for changing a terrain's geometry, like adding mounds or spikes. The orange curve contains tools that apply filtering effects to an existing terrain, like posterizing or equalizing.



These two curves represent different sets of elevation tools. Click the curves to toggle between the two sets.

To switch between sets of elevation tools:

- 1 Click the curves in the bottom left corner of the panel. The button works like a toggle.
- 2 Click again to return to the first set.

Including both sets of buttons, there are a total of 30 elevation tools.

To use an elevation tool:

- 1 Make sure the Elevation tab is displayed. If it's not, click the Elevation title.
- 2 Click an effect tool. 100% of the effect is applied to the Terrain Canvas.
- 3 Click the tool again to increase the intensity of the effect.

Most elevation effects can also be applied gradually.

To apply an elevation effect gradually:

- 1 Move the pointer over an Elevation tool. The pointer changes to a two-headed arrow.
- 2 Click and drag to the left to increase the effect or click and drag to the right to decrease it.

Source Generators

The Source Generator tools can be used in two ways: to generate a terrain from scratch, or to alter the geometry of an existing terrain.

Fractal

The Fractal tool creates terrains based on fractal patterns. It can be applied to an existing image and it can be applied gradually.

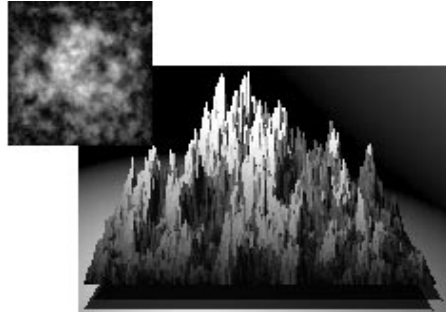

This tool produces terrains based on fractal patterns. The terrains it creates have lots of spikes and valleys. This tool produces good basic terrains.

To create an even more detailed and realistic terrain, set your resolution to greater than 512, then hold Control/Ctrl as you click the Fractal button.

Eroded

This tool applies natural erosion to your terrain. It can also be applied to a blank image to create an eroded terrain, or to an existing image. You can also gradually apply erosion to an image. Eroded produces extremely realistic terrains.

Notice that when animating this type of terrain, material is actually added to the terrain, not removed from it as you might expect.

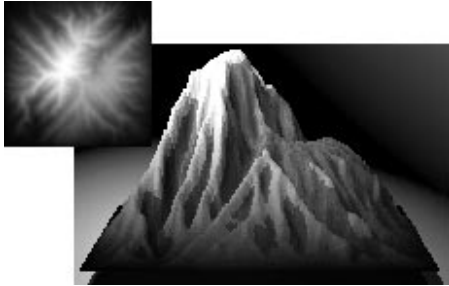

This tool produces terrains based on eroded land. The terrains produced by this tool have deep grooves and canyons.

The Eroded tool is a more intense version of the Erode tool.

Picture

This tool creates terrains from imported images. When you click this tool, the Open dialog appears. You can use this dialog to locate and load a picture to use as a Terrain Canvas. Refer to “Working with Pictures” on page 108 for more information.

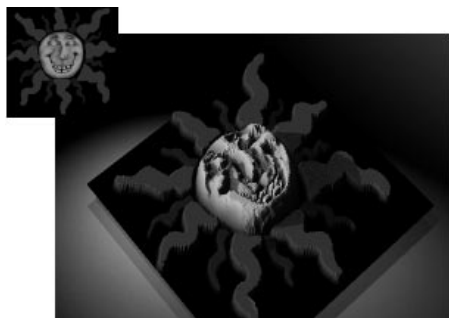

This tool produces terrains based on a picture. This tool is how you import image maps created in other graphics applications.

Using this tool you can import an image map created in another application like Painter or Photoshop.

Basic Tools

The Basic Tools are used to alter an existing Terrain Canvas only. They have no effect on a blank canvas.

Raise/Lower

This tool adjusts the brightness of your Terrain Canvas. Click and drag to the right to lower your height map or click and drag to the left to raise it. Single clicks gradually lower the map.

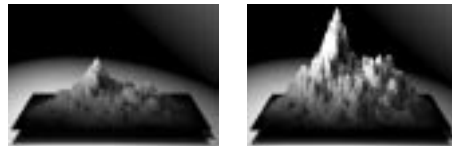

This tool adjusts the brightness of your Terrain Canvas, which raises or lowers the height of the entire terrain.

Sharpening

This tool sharpens the gray values in your Terrain Canvas. Click and drag left to increase sharpening and right to decrease it.

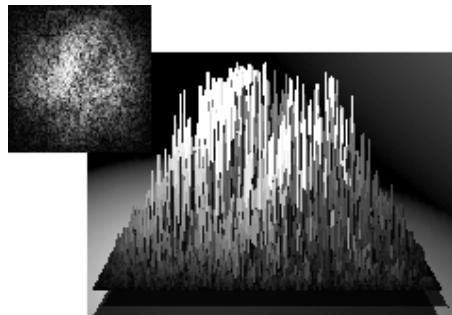

This tool sharpens the Terrain Canvas gray values. You can use smoothing to create spikes or ridges.

Smoothing

This tool blurs the Terrain Canvas. Click and drag right to decrease the blurring effect or left to increase it.

Smoothing is especially effective prior to using the Erode button, since the Erode algorithm works best when there are shades of gray in an image. If your canvas has too many sharp black to white transitions, the Erode may not be as effective.

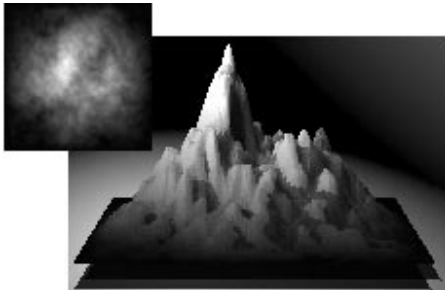

This tool blurs your Terrain Canvas creating smoother black to white transitions.

Gaussian Edges

This tool does not blur your map. It creates a “Gaussian curve” from dark to light, starting from the edges of your Terrain Canvas. This creates edges that gradually transition from dark to light, or start at the lowest possible altitude, and gradually progress into higher altitudes.

Gaussian Edges eliminates the seams between ground and terrain objects, when the ground plane and the terrain have the same surface material. You should apply this tool to any terrain that is going to be sitting on a ground plane in your scene.

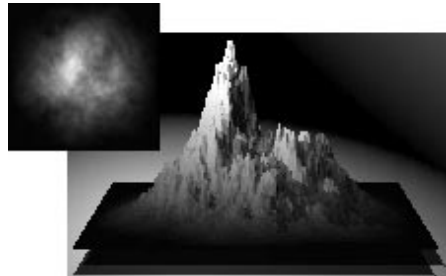

This tool creates gradually ascending edges on your terrain which can create a smooth transition from the ground plane of your scene to the terrain.

Square Edges

This tool creates an abrupt drop at the edges of your terrain. Use this tool when you have a terrain whose edges are not level, and you do not wish to use the Gaussian Edges tool for soft transitions.

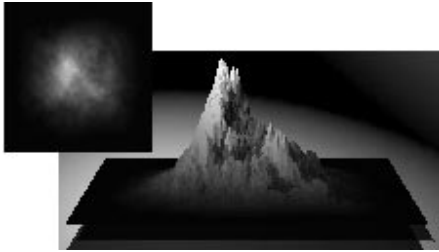

This tool creates an abrupt drop at the edges of your terrain. Use Square Edges to level the edges of a terrain.

You can add a slope to the square edges of your terrain by applying this tool gradually. Click and drag left to increase the slope and right to decrease it.

Round Edges

This tool creates an abrupt circular drop at the edges of your terrain.

You can add a slope to the round edges of your terrain by applying this tool gradually. Click and drag left to increase the slope and right to decrease it.

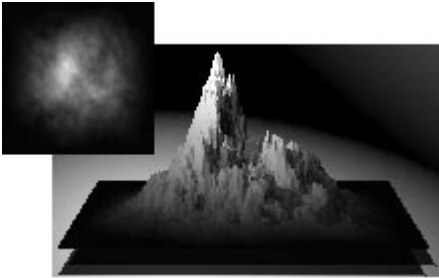

This tool creates an abrupt circular drop at the edges of your terrain. Use Round Edges to create a circular base for your terrains.

Basic Noise

This tool adds roughness to your terrain's surface by adding noise to the Terrain Canvas. Click and drag left to increase the noise and right to decrease it.

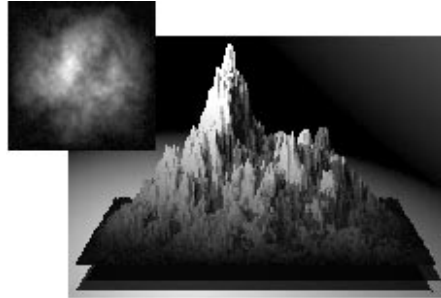

This tool adds roughness to your terrain's surface. Use Basic Noise to create rocky mountains.

Slope Noise

This tool adds roughness to any sloping surfaces in your terrain. Slope Noise adds noise to all the sloping areas of your terrain. Click and drag left to increase the noise and right to decrease it.

Slope Noise has no effect on flat surfaces. More noise is added to steep slopes.

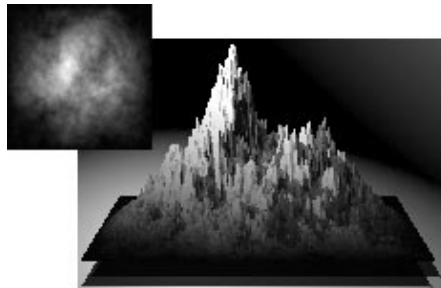

This tool adds roughness to the sloping surfaces of your terrain.

Height Noise

This tool adds small amounts of noise at lower altitudes and more noise at higher altitudes. Click and drag left to increase the noise and right to decrease it.

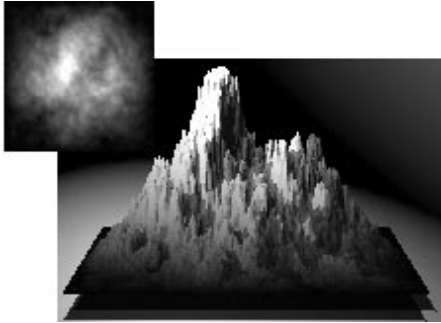

This tool adds a little roughness to your terrain's surface at lower altitudes and more at higher altitudes.

Image Filtering Effects

These tools, located on the orange curve, apply filters to your terrain that act like image filters. They can change the look of the terrain without altering its basic shape.

Spikes

This tool adds spiky structures to your map. When you apply the right material to these structures they can look remarkably like trees if they're viewed from a distance

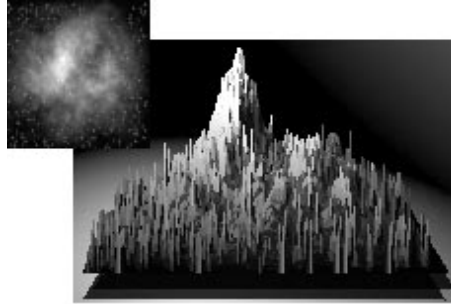

This tool adds spikes to your terrain's surface. Use Spikes when you want to add trees to your terrain.

Mounds

This tool adds mid-sized splotches to your canvas. You can use this tool to create the appearance of stones or boulders under transparent water planes.

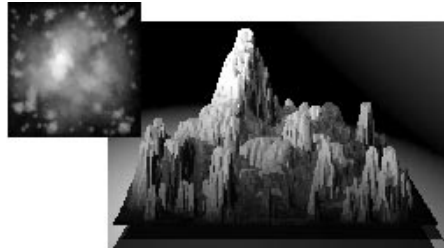

This tool adds splotches to your Terrain Canvas that look like boulders on flat surfaces or towers on sloped surfaces.

Dampen

This tool works like a contrast control. It will push gray values towards either black or white depending on where the gray value falls in the

black/white range. Less than 50% goes to black, greater than 50% goes to white.

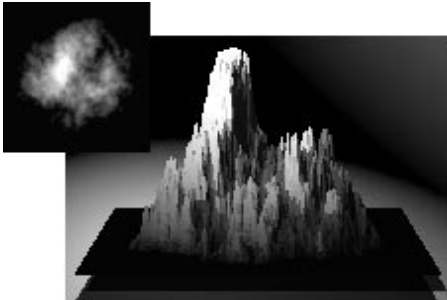

This tool controls the contrast of your Terrain Canvas. Use Dampen to create abrupt drops and valleys.

Equalize

This tool acts like the Equalize function you may have seen in 2D image editing applications. It redistributes gray values in your Terrain Canvas such that a full range from black to white is present in your canvas.

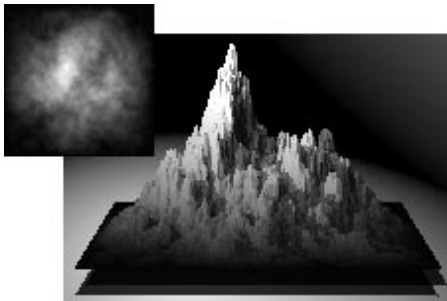

This tool equalizes black and white values in your Terrain Canvas. Use Equalize to eliminate sharp ridges or deep valleys.

Posterize

This tool stratifies the gray levels in your Terrain Canvas, resulting in stair-stepped terrain structures. This is a good tool for creating desert plateaus.

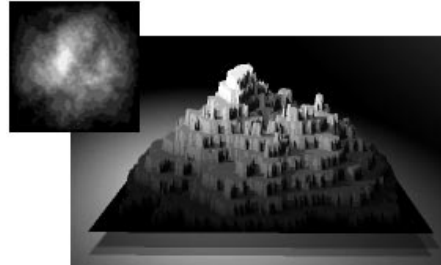

Use Posterize to create stair-stepped desert plateaus or paddy fields on the side of a mountain.

Mosaic

This tool is not a button on the Elevation tab. To use this tool, hold down Opt/Alt as you drag over the Posterize button.

Mosaic creates highly pixelated square structures based on the gray content of your canvas.

This tool is excellent for instant cityscapes. Try adding one of the sci-fi city materials from the Preset Materials Library to a Mosaic terrain.

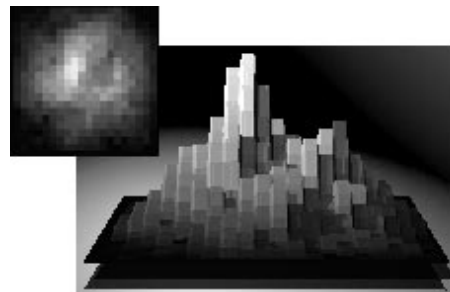

This tool pixelizes your Terrain Canvas. Use Mosaic to create cityscapes.

Sawtooth

This tool modifies your Terrain Canvas based on a sawtooth waveform structure. The results look like schizoid desert canyons and icebergs.

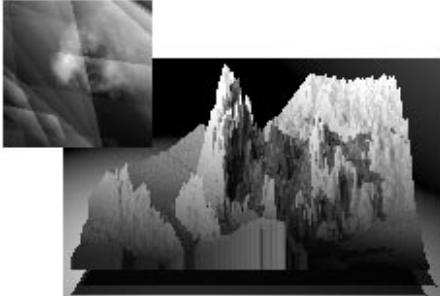

This tool creates schizoid desert canyons or icebergs.

Subcontours

This tool works like a contrast control with the threshold set almost at white. Most values are pushed to black while only the very lightest are pushed to white.

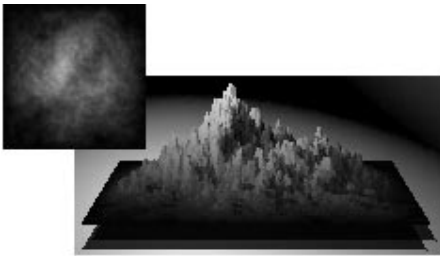

This tool produces spiky peaks with sloping contours.

Subcontours produces spiky peaks with very low, gently sloping contours.

Geometry Effects

This green set of Elevation tools add to the geometry of your terrain, which can alter its basic shape. You can also use most of these tools to create terrains from scratch.

Blob Maker

This tool creates a smooth, circular structure within your existing Terrain Canvas. Click and drag left or right to change the size of the structure. Click and drag up and down to set the vertical location of the structure.

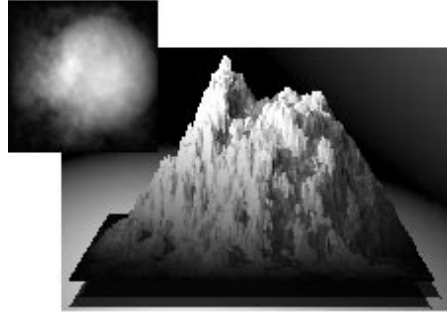

This tool creates circular structures within your Terrain Canvas.

Relief Noise

This tool acts like an emboss effect. It will emboss the grayscale data in your canvas and convert it to height information.

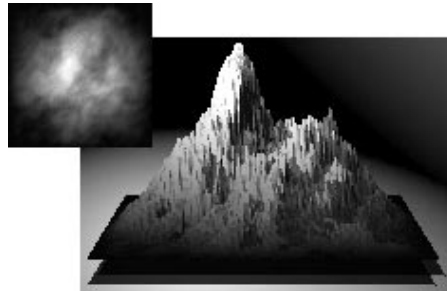

This tool embosses the grayscale data in your Terrain Canvas.

Raise Edges

This tool acts like an inverted version of the Square Edges tool. It creates abrupt increases in altitude at the edges of your terrain.

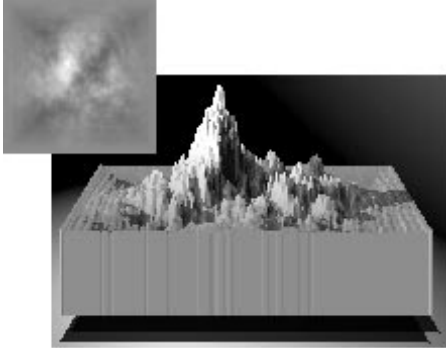

This tool creates abrupt increases in altitude at the edges of your terrain.

Subplateaus

This tool smears your grayscale data in one direction while averaging the gray values. The result is natural structures not unlike those created by the Mounds effect, except that these structures are more directly related to your original gray data.

Because it creates boulder-like structures, this tool is good for making tidepools.

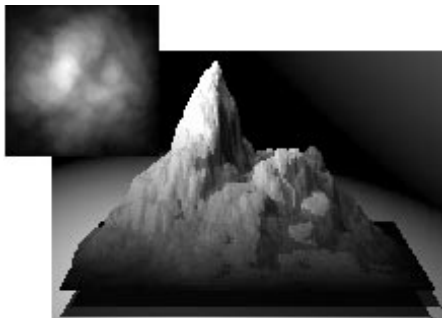

This tool creates boulder-like structures within your Terrain Canvas.

Cross Ridges

This tool creates sharp ridges in a cross pattern. It creates very interesting canal-like structures.

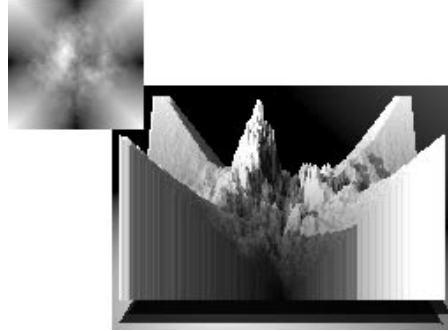

This tool creates canal-like structures within your Terrain Canvas.

Cross Ridges 2

This tool is the inverse of the Cross Ridges tool. Instead of creating canals, it creates peaks.

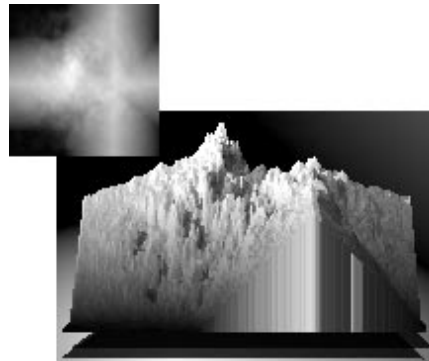

This tool creates peak-like structures within your Terrain Canvas.

Bubble Ridges

Similar to the Blob Maker, the spherical structure this tool creates is of a consistent size. Dragging this button allows you to place the structure anywhere you like in your canvas.

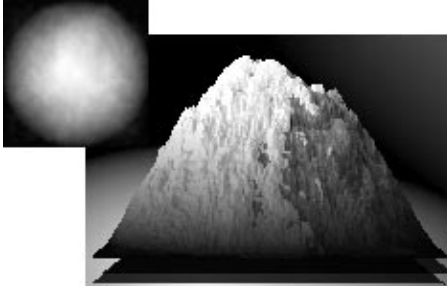

This tool creates a spherical structure within your terrain that can be placed at any point in your canvas.

Painting Terrains

Although you can create some very spectacular terrains using just the elevation tools, there are times when you want to create a precise Terrain Canvas. The Terrain Editor's paintbrush lets you paint any type of terrain you wish. Using the Paintbrush, you can re-create real-world topographical maps or design landscapes with specific contours.

Setting Up the Paintbrush

Before painting with the Paintbrush, you should set up some of its parameters. Using the brush settings you can control the size, hardness, strength and color of your brush.

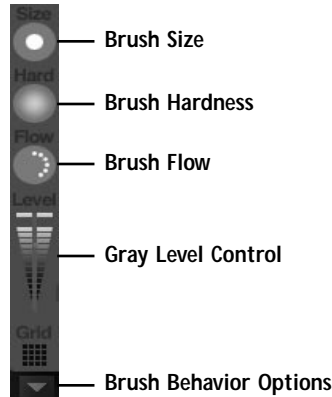

Use the Paintbrush settings to control the attributes of your brush.

To set brush attributes:

- 1** In the Terrain Canvas frame, drag over the Size control.
Drag away from the center to increase the size of the brush and towards the center to decrease it.
- 2** Drag over the Hard control.
Drag towards the center of the control to make brush edges harder or away from the center to make brush edges softer.
- 3** Drag the pointer over the Flow control.
Drag to the right to increase the flow or to the left to decrease it.
Brush Flow determines the strength of the paintbrush. The higher the flow setting, the more color is applied.
- 4** Drag over the Level control.
Drag down to apply a darker gray, or up to apply a lighter gray.
Since you're painting altitudes, lighter grays result in higher points and ridges while darker grays create lower points and valleys.

The default level is 100% gray. However, it effectively paints at 50% because of the other default settings.

While you're painting, you may want to re-create a specific altitude in different parts of the terrain. If you've changed the brush settings, re-creating a specific altitude can be quite difficult. However, using the Height Picker tool you can quite easily re-create altitudes by picking up gray levels from different parts of your image and applying them to the brush.

To pick up gray levels from the terrain image:

- 1 While holding down the spacebar, move the cursor over the Terrain Canvas and click the desired altitude color. The color is applied to the brush.
- 2 Drag the brush over a different area of the canvas. The altitude color you picked up is applied to the new area.

Brush Behaviors

The paintbrush in the Terrain Editor paints elevations by default, but this is not the only way of painting using the brush. You can also set the brush to paint effects. This lets you apply elevation effects locally, or to increase/decrease existing gray levels in your Terrain Canvas.

To paint elevations:

- 1 Make sure the Elevation tab is visible. If it's not, click the Elevation title.
- 2 Click the triangle icon to the right of the Brush Behaviors heading and choose Paint Elevation from the menu.

The brush paints in shades of gray that are then used to generate altitudes. This is the default brush behavior.

To apply an effect locally:

- 1 Make sure the Elevation tab is visible. If it's not, click the Elevation title.
- 2 Click the triangle icon next to the Brush Behavior heading and choose Paint Effect from the menu.
- 3 Hold down the Spacebar and click the Elevation effect you want to paint.
- 4 Drag the paintbrush over an area of your canvas.

To remove an effect locally:

- 1 Click the triangle icon next to the Brush Behavior heading and choose Unpaint Effect from the menu.
- 2 Drag the paintbrush over an area of your canvas where you applied an effect locally. The Unpaint Effect brush only affects areas where you applied an effect with the paintbrush.

An effective way of using this brush is to paint an effect in broad, easy strokes, and then selectively unpaint areas of effect away.

To erode areas of your terrain:

- 1 Click the triangle icon next to the Brush Behaviors heading and choose Erode from the menu.
- 2 Drag the paintbrush over the area you want to erode.

The paintbrush applies the erosion effect to the area painted over.

To lighten gray levels:

- 1 Click the triangle icon next to the Brush Behavior heading and choose Maximum from the menu.
- 2 Drag the paintbrush over an area you want to lighten.

In this mode, gray levels in your canvas that are below the current gray level are lightened to match the current level. Values above the current Level setting are untouched.

To darken gray levels:

- 1 Click the triangle icon next to the Brush Behavior heading and choose Minimum from the menu.
- 2 Drag the paintbrush over an area you want to darken.

In this mode, gray levels in your canvas that are above the current gray level are darkened to match the current level. Values below the current Level setting are untouched.

Modifying Brush Behavior

The Option/Alt key can modify the behavior of the paintbrush on-the-fly.

- In Elevation mode, Option/Alt inverts the gray level. For example, if you're painting white, holding down Option/Alt will paint black.
- In Paint Effect mode, the Option/Alt key will toggle to Unpaint Effect mode.

Hold down Shift to constrain the pen movements in 45 degree steps.

Filtering Terrains

Filtering is the process of adjusting the gray-scale curve of your Terrain Canvas. By adjusting the grayscale curve, you create a custom elevation effect.

How Filtering Works

The Filter area is essentially a graph that represents gray level input from black to white horizontally, and gray level output from black to white vertically.

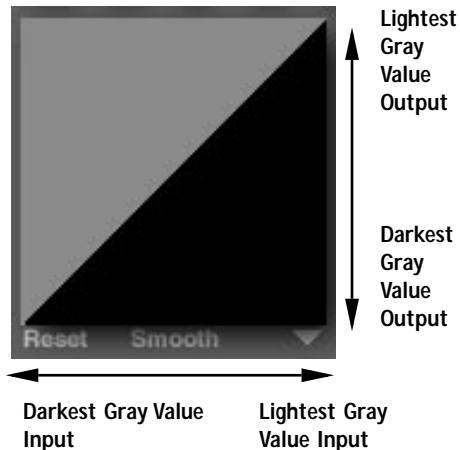

The Filtering graph expresses all the input and output gray values in your Terrain Canvas.

The default diagonal filter creates a graph where all values input as black are also output as black, and all values input as white are also output as white. That is why your Terrain Canvas appears unchanged—none of its gray level values have been altered.

By dragging in this Filter area, you can remap the gray values in your Terrain Canvas.

To see how filtering works:

- 1 Place your cursor (which changes to a Pen within the Filtering area) in the top left corner of the Filter Area.
- 2 Drag diagonally to the bottom right corner.

As you can see in the Preview area, your Terrain Canvas is inverted.

The original graph stated that all values input as black were output as black and all the values input as white were output as white.

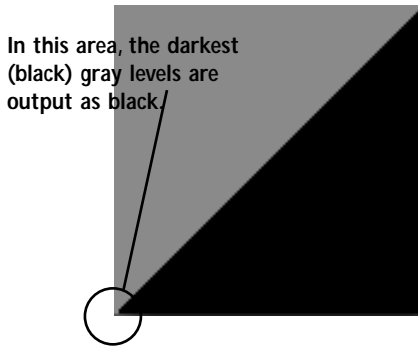

In the original Filtering graph all values input as black are output as black and all values input as white are output as white.

The new graph you created now states that all values input as black are output as white and all the values input as white are now output as black. In other words all the dark values are light and all the light values are dark.

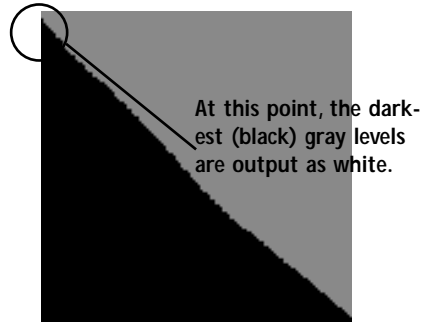

In the new Filtering graph all values input at 0 are output at 255 and all values input at 255 are output at 0.

This is a drastic example. In most cases you would adjust more specifically, like lightening the midtone grays or darkening specific gray values. Remember that this graph represents your Terrain Canvas, so you're changing the shape of your terrain object as you adjust gray values.

The Filtering Tab

The Filtering tab is divided into three areas: the Filtering graph, the graph preview and the filtering presets.

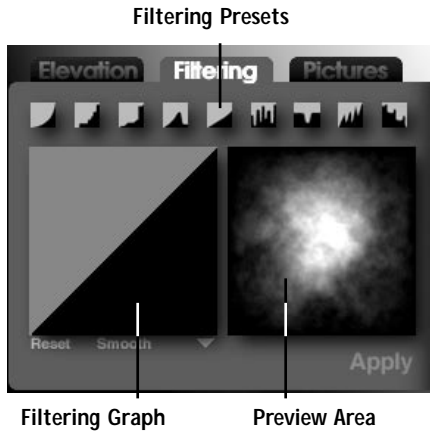

Use the Filtering tab to edit the Filtering graph and apply filtering presets.

The Filtering graph displays your Terrain Canvas's gray levels as value inputs and outputs. You can edit this graph to adjust the gray level values in your canvas.

Next to the graph is the Preview area. This area shows you what your Terrain Canvas would look like if applied to the current Filtering graph. This area automatically updates as you make changes to the graph.

Along the top of the tab are the nine Filtering presets you can apply to the graph. Each preset represents a different predefined graph. They are designed to create specific changes in gray levels, like smooth gradients and abrupt transitions.

Working in the Filtering Tab

Altering the Filtering Graph

The best way to start adjusting the Filtering graph is to determine the type of effect you want to create. For example, if your canvas is too dark, raise the value of the darker gray value

inputs by drawing a ridge in the left side of the graph.



Drawing a ridge on the left side of the graph...

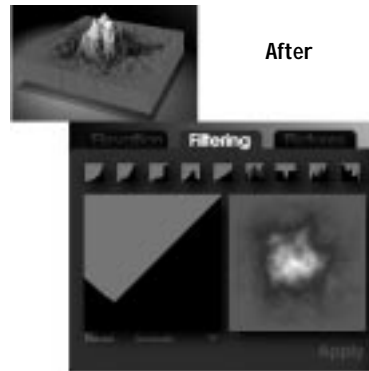

...raises the value of the darkest grays in your Terrain Canvas.

To alter the Filtering graph:

- 1 Make sure the Filtering tab is visible. If it's not, click the Filtering title or press the Tab key until it is displayed.
- 2 Drag your pointer over the area of the Filtering graph you want to adjust.
When you drag over a black area, the pencil draws in gray; dragging over a gray area draws in black.

Tracing over any lines you've drawn erases them.

To undo all changes to the Filtering graph:

- 1 Make sure the Filtering tab is visible. If it's not, click the Filtering title or press the Tab key until it is displayed.
- 2 Click the Reset text button below the Filtering graph.
The graph returns to the default Filtering graph.

To soften harsh transitions in the graph:

- 1 Make sure the Filtering tab is visible. If it's not, click the Filtering title or press the Tab key until it is displayed.
- 2 Click the Soften text button below the Filtering graph.
- 3 Click the Soften button again to soften the transitions more.

Applying Presets

Filtering presets are provided to help you get started adjusting the Filtering graph. These presets are designed to provide different effects. The best way of using these presets is to apply them to your graph and see what happens.

To apply presets:

- 1 Make sure the Filtering tab is visible. If it's not, click the Filtering title or press the Tab key until it is displayed.
- 2 Click one of the preset buttons along the top of the tab. The current graph is replaced with the preset graph.

Applying Filtering Changes to Your Terrain Canvas

Although any changes you make to the graph are applied to the Preview area, they do not automatically affect your Terrain Canvas. You have to Apply the changes before they affect the canvas.

You can temporarily apply your changes to the 3D Preview in real-time by holding down Control/Ctrl as you click and drag over the Filtering graph.

To apply the Filtering graph to the 3D Preview:

- Hold down the mouse button over the filter graph preview. The 3D preview updates.
When you release the mouse the 3D Preview switches back to the unfiltered terrain.

To apply filtering changes to the Terrain Canvas:

- Click the Apply text button beneath the Preview area.

Blending the Filtering Graph With the Terrain Canvas

The Filtering Tab offers several ways of applying your Filtering graph to the Terrain Canvas. You can apply the graph directly or you can blend the graph with the canvas.

When you use a blending option you're essentially drawing a grayscale gradient and then blending it with your original canvas.

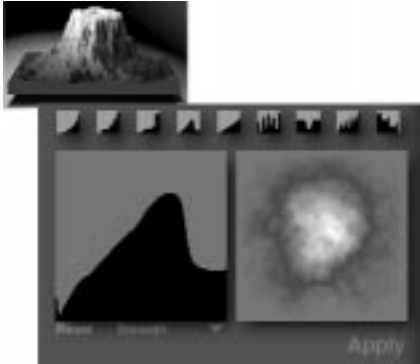

This terrain was altered by directly applying a filtering effect.

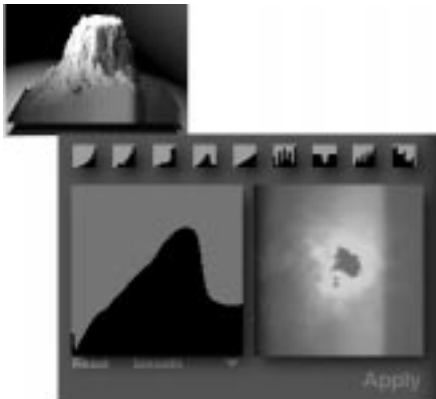

This terrain was altered by blending a filtering effect with the original canvas.

To blend the Filtering graph with the Terrain Canvas:

- 1 Adjust the Filtering graph to achieve the desired effect.
- 2 Click the triangle icon below the Filtering graph and choose an option from the menu:

Horizontal horizontally blends your Filtering graph, expressed as a grayscale gradient, with your Terrain Canvas.

Vertical vertically blends your Filtering graph, expressed as a grayscale gradient, with your Terrain Canvas.

Horizontal Add horizontally blends your Filtering graph, expressed as a grayscale gradient, with your Terrain Canvas.

This option uses a slightly different algorithm than the previous Horizontal option: it's not a traditional Additive, but an average of the existing terrain grayscale values with the maximum of the Terrain and Filter values.

Vertical Add vertically blends your Filtering graph, expressed as a grayscale gradient, with your Terrain Canvas.

This option uses a slightly different algorithm than the previous Vertical option: it's not a traditional Additive, but an average of the existing terrain grayscale values with the maximum of the Terrain and Filter values.

- 3 Click Apply.

Using Creation Models

Bryce provides a selection of terrain models from which you can choose. When you select a terrain from the list of models, you get a randomized version of the model you select.

To access a terrain model:

- 1 From the Terrain Editor, select the Pictures tab.
- 2 Click and hold on Load Image.
- 3 Select a model from the menu that appears.

The last model you selected will always be the default model.

Creating Terrains Using Pictures

The Terrain Editor converts grayscale values in the Terrain Canvas into altitudes to create terrain objects. You can take advantage of this process to create unique terrains based on the grayscale values in a picture.

The Terrain Editor's Picture tab lets you import a picture into the Terrain Canvas. You can then apply elevation effects or filter it just as you would any other Terrain Canvas.

The Pictures Tab

The Picture Tab is made of three picture squares and a blend control. The first two picture squares let you load a picture to use a terrain and the third square shows you the result of combining the two pictures. The blend control lets you specify how the pictures are combined.



Use the Picture tab to load and blend pictures to create unique terrains.

Working in the Pictures Tab

Loading Pictures

You can load any two pictures from anywhere on your system. You can also copy and paste images from the Clipboard.

To load pictures:

- Click the Load text button above the picture box into which you want to load the picture.

From the Picture button in the Elevation tab, hold down Option/Alt key to load the picture's color data directly into the 3D Terrain preview. This allows you to see the interaction between the picture and the grayscale to height interpretation of its luminance values. The color data is only for viewing purposes and will not render with the terrain.

To copy and paste a picture into the Picture tab:

- 1 In another application, copy the picture you want to use to the Clipboard.
- 2 In the Picture tab, click the Paste text button below the picture box where you want the picture to appear.

When you use Command+V/Ctrl+V to paste from the Clipboard, the picture always appears in the first square.

Blending Pictures

Once you have a picture in each of the first two squares, you blend them to create a third image that is used to create the new Terrain Canvas.

To blend pictures:

- 1 Load pictures into the first two squares.
If you load only one picture a white square is used as the second blend image.
- 2 Click the triangle icon under the third picture box and choose a Blend mode from the menu:

Blend compares each corresponding pixel from the first two squares, and displays an average of the two in the corresponding location of the third square.

Minimum compares each corresponding pixel from the first two squares, and displays the darker of the two in the corresponding location of the third square.

Subtract compares each corresponding pixel from the first two squares, subtracts the brightness value of one from the brightness value of the other, and displays the result in the corresponding location of the third square.

Add compares each corresponding pixel from the first two squares, adds the brightness value of one to the brightness value of the other, and displays the result in the corresponding location of the third square.

- 3 Drag the pointer over the Blend control.
Click and drag to the left to use more of the first image in the blend. Click and drag to the right to use more of the second image.

Applying Changes to the Terrain Canvas

Although the results of blending pictures appears in the third picture box, it is not automatically applied to your Terrain Canvas.

To apply a picture to the Terrain Canvas:

- Click the Apply text button beneath the third picture square.

Adding Color to Terrains

Color in the Terrain Editor is used as a visual aid to help you see the relationship between color values and altitude. This color only exists in the Terrain Editor and is not applied to the terrain object.

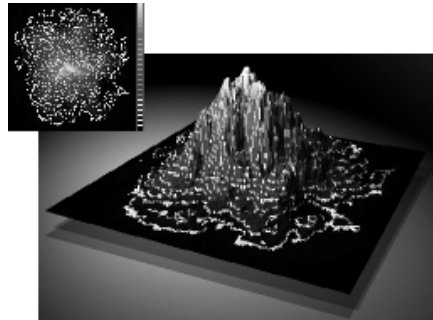

You can apply a color gradient to your Terrain Canvas to help you visualize the relationship between color values and altitude.

When you apply color in the editor, it maps a gradient to the altitudes in your Terrain Canvas. For example, if you apply a gradient from blue to yellow, blue might represent the lowest altitude while yellow may represent the highest. Which colors are mapped to which altitudes is left completely up to you.

Gradients can be extremely useful when you're filtering terrains, as they make the differences between gray levels more visible.

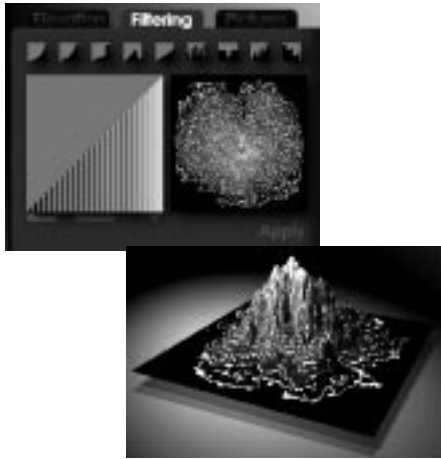

You can apply a color gradient to your Terrain Canvas it also appears in the Filtering tab. This makes it easier to see the differences in gray levels.

Mapping Color to Your Terrain Canvas

The Terrain Editor's color picker contains all the gradient you can apply to your terrain. The gradient you select is applied to both the Terrain Canvas and the 3D Terrain Preview.

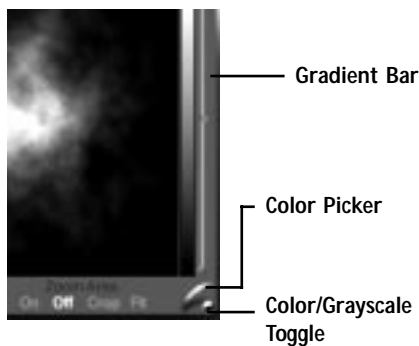

Use the Color Picker button to choose a color gradient and the gradient bar to set color mapping.

To map colors to your Terrain Canvas:

- 1 Click the Color Picker button in the bottom right corner of the Terrain Canvas Frame and drag over a gradient in the palette.

The gradient you selected appears in the Gradient bar and is mapped to the Terrain Canvas and the 3D Terrain Preview.

- 2 Drag the gradient up or down to map the colors to altitudes.

The colors at the bottom of the gradient represent the lowest altitude and those at the top represent the highest.

The Gradient Bar has two modifiers:

- Opt/Alt resets the Gradient Bar.
- Command-F/Ctrl+F flips the colors in the gradient.

To return to grayscale:

- Click the /Grayscale to switch back to the default gray gradient.

Although gradients are meant to be used only in the Terrain Editor, you can apply the gradient to the Terrain's Diffuse channel. The gradient then becomes the terrain's Diffuse color. This allows you to render the gradient with the terrain.

To remove a gradient from a terrain's Diffuse channel:

- 1 Open the terrain in the Terrain Editor.
- 2 Click the Color/Grayscale toggle.

Clipping Terrains

Using the Terrain Editor's clipping controls, you determine which values in your terrain are rendered as the final terrain object. The Clipping controls next to the Gradient bar represent the render range for the terrain. Anything outside the range included in the brackets will not be rendered.

You can use these controls to eliminate any unwanted information from the terrain without altering its basic shape. For example, you can keep the main terrain while eliminating the black square on which it sits.

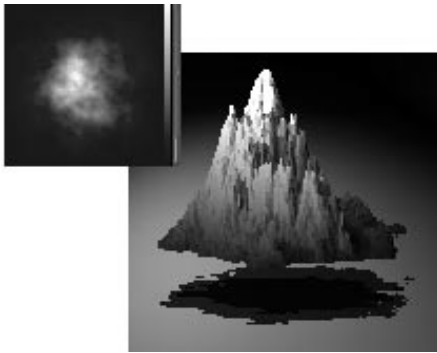

Using the Clipping Bracket you can eliminate unwanted areas from the terrain's edges. This feature can be useful when you're creating islands.

The clipping feature is particularly useful when editing a Symmetrical Lattice. The maximum lower range of the Clipping Bracket determines where the two halves of the Symmetrical Lattices are joined.

To set the clipping range:

- 1 Drag the top of the Clipping Bracket to set the maximum upper range.
Any areas in the Terrain Canvas whose gray levels fall outside the bracket's maximum

upper range will appear colored to indicate they will be omitted from rendering.

- 2 Drag the bottom of the Clipping Bracket to set the maximum lower range.

Any areas in the Terrain Canvas whose gray levels fall outside the bracket's maximum lower range will also appear colored to indicate they will be omitted from rendering.

The out-of-range colors for upper and lower limits are different, to better enable you to distinguish upper and lower clipped areas at a glance. Upper out-of-range color is usually blue, and lower out-of-range is usually red, though the colors change for many of the color maps.

To reset the Clipping Bracket:

- Hold down Option/Alt and click the bracket.

To move the entire Clipping Bracket at once:

- Click the center of the Clipping Bracket and drag up or down.

Terrain objects are actually hollow, so if you clip the upper range off your terrain, you'll be able to see through the top of the terrain to whatever is underneath. To make the top solid, you should select Make Solid from the drop-down menu.

Saving Terrains

Since the terrains you create in the Terrain Editor are objects in the scene, you can save any terrain in the Preset Objects Library just as you would any object. Refer to “Adding and Deleting Preset Categories and Objects” on page 120 for instruction on saving objects to the preset library.

Exporting Terrains

The Export Terrain Lab allows you to convert Bryce terrains into polygonal meshes. The Lab provides you with full control over the level of detail of the polygonal mesh.

You can adjust the number of polygons with realtime feedback so you can instantly see the resulting change to your mesh.

In addition, the Lab allows you to manage the all-important texture maps so that your exported meshes retain the cool look as generated within Bryce.

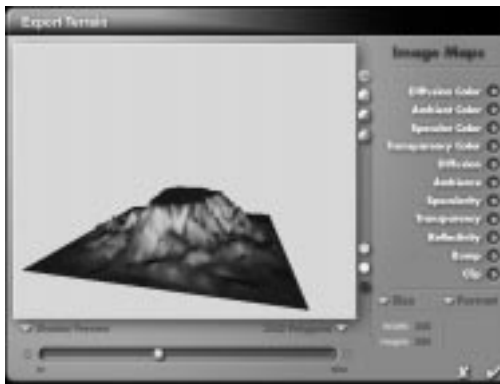

The Export Terrain Lab.

To access the Export Terrain Lab:

Do one of the following:

- Select a terrain and go to **File menu >Export Object**,
or
- Edit and save a terrain in the Terrain Editor and click Export, which is located at the bottom of the map view.

Features of the Export Terrain Lab

The Export Terrain lab is divided into two areas:

- The polygonal mesh previewer with polygon count slider.
- The image map controls.

The mesh previewer allows you to instantly examine the quality of the current tessellation.

To manipulate the mesh:

- To rotate the mesh, click and drag in the previewer.
- To zoom the mesh in and out, Command/Control-click and drag in the previewer.
- To change the previewer display mode, select one of the buttons to the right of the previewer.

Available preview modes are: Wireframe, Shaded, Textured, and Textured With Wireframe Overlay.

- To adjust the colors of the wireframe and the shaded preview select the color swatches underneath the preview mode buttons.

- To adjust the polygon count, use the slider below the previewer to adjust the polygon count. This changes the quality of your mesh. The number of polygons in the mesh is displayed in the right bottom corner of the previewer.

Preview Options

Selections on the right hand side of the Preview window allow you to preview your terrain in the following ways:

- Wireframe
- Shaded
- Textured
- Textured with Wireframe Overlay

Types of Tessellations

You can create two different types of tessellations in the Export Terrain Lab: Grid and Adaptive.

The default method is Adaptive. The initial tessellation is set to 6,000 polygons. If this is not sufficient you can add polygons by selecting Add Polygons in the Options Menu. This can be found at the right bottom corner of the previewer.

To switch between tessellation types:

To switch between Grid and Adaptive tessellations, click on the triangle to the left of the previewer and select the tessellation type.

Grid Tessellations

Grid tessellates the original height field with a grid.

In order to achieve a good mesh representation of the source terrain, selecting Grid requires a large number of polygons. However, this method is suitable for geometric shapes.

Adaptive Tessellations

Adaptive achieves much lower polygon counts with good representation of the terrain.

This is an excellent choice when the terrain models natural landscapes.

Exporting to MetaStream

When exporting to MetaStream, MetaCreations' multi-resolution streaming file format, you can select additional options: Clamp Min and Clamp Max.

These options define the lowest and highest polygon counts within the multi-resolution mesh.

To reset the Clamp Min and Clamp Max:

- Select Reset Clamps within the Options menu.

To apply the Clamps:

- 1 Use the slider to set the desired lower polygon count.
- 2 Select **Options menu>Clamp Min**.
- 3 Use the slider to set the desired higher polygon count.
- 4 Select **Options menu>Clamp Max**.

If Clamp Min and Clamp Max are set to the same amount, the MetaStream file will contain a single resolution.

Handling Image Maps

The second area of the Export Terrain Lab deals exclusively with handling image maps.

A large part of the appeal of Bryce terrains are Bryce materials, which consist of different significant properties. Each of these properties can be exported, along with their geometry, through the Export Terrain Lab.

The image map controls lets you refine which of the material properties you wish to export by selecting out of the list of ten. By default any material properties of the terrain that use image maps will be exported.

Depending on the selected export file format, the image maps will be imbedded within the export file. If, however, the export file format does not support imbedding of image maps, they will be saved out as separate image files in the same folder as the export file. The filename of each separate image will be the name of the export file appended with the name of the appropriate material property.

To adjust the resolution of the exported image maps:

- Select one of the presets in the Size Menu.

To save the tessellated terrain and all its image maps:

- Click on the OK icon.

If you do not wish to save, click on Cancel.

To export a terrain:

- 1 Create a terrain and apply materials.
- 2 Either select the terrain and go to **File>Export Object** or enter the Terrain Editor and click Export.
- 3 Choose the desired file format and target folder.
- 4 Adjust the complexity of the mesh.
- 5 Select material properties to be exported as image maps.
- 6 Select image map size.
- 7 Click the OK icon to cause the tessellated mesh to be written to the exported file.

Tips for Speeding Up the Terrain Editor on Slower Machines

To speed up performance on slower machines, disable both the Realtime Linking and AutoRotate options.

To speed up the Elevation effects, use the single-click method rather than the click- drag “dial in” method, as the latter can be quite slow on these machines.

When you create a terrain in your Bryce scene, a natural impulse is to immediately dress it up with a cool material and render it right away to see what it looks like. For serious composition, consider keeping your terrains free of textural attributes until the final stages, as procedural textures take longer to render than smooth shaded surfaces. This will keep you working rapidly on your composition. Then, before your final output, you can take some time to design surfaces for your terrain.

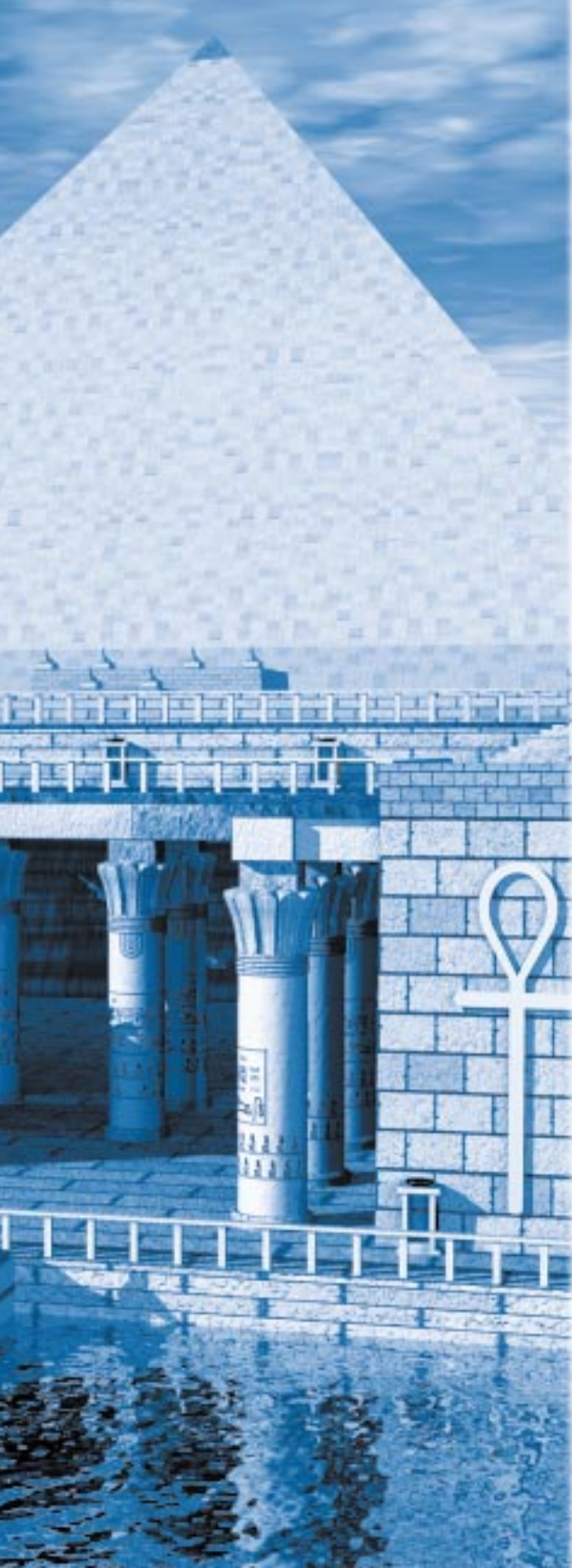

9

Materials

Materials are what bring your Bryce environment to life. A material defines the surface properties of an object in your scene. It has the power to turn a bunch of polygons into an island or the peaks of the Himalayas. You can also alter the basic function of an object. A simple cylinder can become a pillar, a tree trunk or a metal pipe, just by adjusting the properties of the material applied to it.

In Bryce, a material isn't just a picture that's wrapped around an object; it's a truly 3D surface. The material properties you assign to an object are applied to the whole object—inside and out.

Bryce's new volume materials let you apply a material to the interior of the object as well as to its surface. The Volume Material controls let you set how the entire object's volume reacts to its environment.

Material Structure

A material is made up of fourteen channels. Each of these channels defines a different property of an object's surface. When you combine all the channels together you get a material.

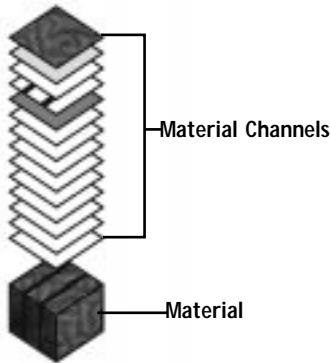

A material has fourteen channels that define its surface properties. The combination of the values of all the channels produces a material.

New materials are created by adjusting the values for each channel.

There are two types of materials you can create in Bryce: surface materials, which define the properties of an object's surface, and volume materials, which define the properties of an object's volume.

Understanding Surface Material Channels

The fourteen channels of a surface material each represent a different surface property. These properties simulate different physical properties of a surface, and the combination defines how the object's surface interacts with light in the Bryce environment.

To understand how the channels work you need to understand a little about how you perceive light and color.

The color and size of an object is determined by how the light that hits the object is reflected back to your eye. Objects appear green because they reflect green light. Objects are reflective because they reflect light. An object appears shiny because it reflects light back at you.

An object appears transparent because light passes through its surface, hits the objects behind it and is reflected back through the surface. Bryce's material channels simulate all these behaviors. When you set a channel value, you're setting how your object's surface interacts with light that hits it, whether that light is from a direct source like the sun, or an indirect source like light reflected off other surfaces.

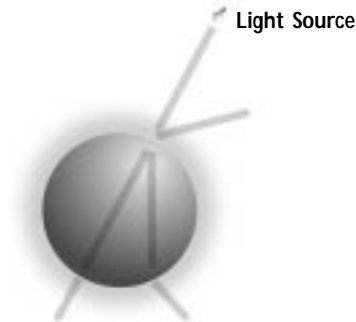

Material channels simulate physical properties of an object. When you set channel values, you're defining how the object's surface, or volume, interacts with light.

When you're creating volume materials, your settings not only control how light interacts with the surface of the object, but also how it interacts with the object's volume.

The effects of the channels are additive, meaning that each value you set directly affects all the other values. So, if you set the Diffuse

Color to yellow and the Ambient Color to Blue, the object will have a greenish tint.

Channels are interdependent. For example, you won't see the effects of the Transparent Color if the object is not transparent.

When you're using these channels it's important to understand the physical property they're simulating. Only in this way can you make meaningful adjustments to the component values.

For example, if you set both Transparency and Reflection to 100, you'll get an unusually bright object that doesn't look very realistic. The reason for this is that the object is emitting more light than it is receiving, something it couldn't do in reality.

Since material channels simulate real-world surface properties, you should try to keep channel values within a realistic range.



For example, here Transparency and Reflection are both set to 100. With these settings you're saying that 100% of the light that hits the object, passes through its surface, and 100% of the light that hits the object is also reflected off its surface.

The result is an object that emits more light than it receives because it's reflecting the light that hits it as well as the light from behind it.



In reality, an object can only reflect a portion of the light that's passing through it. So, Transparency and Reflection values should always add up to 100.

A good rule of thumb to keep in mind while you're setting these channels is that the Transparency and Reflection channels should always add up to 100, and Diffusion and Ambience values should also always add up to 100.

Each surface material is made up of fourteen channels, divided into three groups:

Color channels

- Diffuse Color
- Ambient Color
- Specular Color
- Transparent Color
- Specular Halo
- Volume Color

Value channels

- Diffusion
- Ambience
- Specularity
- Metallicity
- Bump Height

Optics channels

- Transparency
- Reflection
- Refraction

Color Channels

The Color group contains all the channels that control the color reflected off an object's surface. The channels in the Color group are Diffuse Color, Ambient Color, Specular Color, Transparent Color and Volume Color.

Diffuse Color, Ambient Color, and Specular Color define the colors the surface reflects when direct light hits it. For example, Diffuse Color defines the color that is reflected in all directions when direct light hits it and Specular Color is the color that appears in the object's highlight.

These color channels are directly related to the Diffusion, Ambience, and Specularity channels. Diffusion, Ambience, and Specularity control how light reflects off the object, while Diffuse Color, Ambient Color and Specular Color control the color of that light.

So, for example, if you selected yellow as the Diffuse Color, the object appears yellow. The intensity of the yellow color is controlled by the Diffusion channel. Refer to "Diffuse Color" on page 197, "Ambient Color" on page 199, and "Specular Color" on page 200 for more information.

Transparent Color sets the color of any light that passes through the surface of the object and Specular Halo controls the size of the highlight that appears when an object has a shiny surface. Refer to "Transparent Color" on page 203 and "Specular Halo" on page 200.

The remaining color channel, Volume Color, controls the color of the interior of the object. Refer to "Volume Color" on page 206 for more information.

Value Channels

The second group of channels, the Value group, controls how much light affects an object. The channels in the Value group are Diffusion, Ambience, Specularity, Metallicity and Bump Height.

Diffusion, Ambience, and Specularity define how the surface interacts with direct light. They let you control how much direct light affects the surface of an object. In a physical environment, these channels control how shiny, dark or bright the object appears. Refer to "[Diffusion](#)" on page 196, "Ambience" on page 197 and "Specularity" on page 199 for more information.

Metallicity is related to Reflection. It determines how much reflected light is filtered through the Diffuse Color. Refer to "Volume Material Channels" on page 206 for more information.

Bump Height controls the height of any bumps or dents on the object's surface. Refer to "Bump Height" on page 202 for more information.

Optics Channels

The Optics group of channels controls the intensity of optical effects produced by the object's surface. The channels in the Optics group are Transparency, Reflection and Refraction.

Transparency and Reflection channels control how indirect light interacts with the object's surface. In a physical environment, these channels control how transparent or reflective

the object appears. Refer to “Transparency” on page 202 and “Reflection” on page 205 for more information.

Refraction is directly related to Transparency. The Refraction channel sets how much the light that passes through the object is bent. Refer to “Refraction” on page 204 for more information.

Understanding Volume Material Channels

Surface materials define the properties of the surface of an object. The interior of the object is empty. If you were to fly through the object you would see one layer of material, emptiness and then another layer of material. A volume material is applied to the entire object, both inside and out. If you were to fly through a volume material you would be surrounded by a material.



Blue spots become blue spheres when the texture is applied as a Volume Material.



When you create a volume material, the channels define not just the surface of an object, but its volume as well.

When you’re setting channel values for a volume material, you’re setting up how light will interact with the object’s volume. Channels control whether the interior of an object is bright, dark, shiny, or transparent.

In most cases the interior of an object will be filled with a texture. If so, the channels control the surface properties of the elements within the texture.

For example, if you apply blue spots as a volume material, you get a volume filled with blue spheres. The channels then control whether those spheres are bright, dark, shiny, or dull.



When the interior of an object is filled with a texture, the material channels control the surface properties of the elements within the texture.

In this example, the Specularity channel is used to make the blue spheres within an object shiny.

Volume materials are made up of thirteen channels, divided into three groups:

Color channels

- Diffuse Color
- Ambient Color
- Specular Color
- Transparent Color
- Specular Halo
- Volume Color

Value channels

- Diffusion
- Ambience
- Specularity

Volume channels

- Base Density
- Edge Softness
- Fuzzy Factor
- Quality/Speed

The channels in the Color and Value groups work exactly as they do for surface materials, except that the channel settings are applied to the object's volume instead of its surface.

Volume Channels

The Volume channels control special volume properties of the object's interior.

Base Density controls the density of the object. This channel defines how much material there is in the interior of an object. As a result, Base Density controls how much light passes into the object. A solid object doesn't allow any light to pass through it, while less dense objects

allow more light in. Refer to "Base Density" on page 206 for more.

Edge Softness, Fuzzy Factor and Quality/Speed control the appearance of texture elements within the material. Edge Softness and Fuzzy Factor control the quality of the edges and sharpness of the texture while Quality controls the render quality of the material. Refer to "Edge Softness" on page 207, "Fuzzy Factor" on page 207 and "Quality/Speed" on page 207 for more.

Understanding Material Components

Each Bryce material channel can contain up to three components that determine the channel's setting. A component can be a color, a texture or a numerical value. A texture can be either a 2D texture (picture) or a 3D texture.

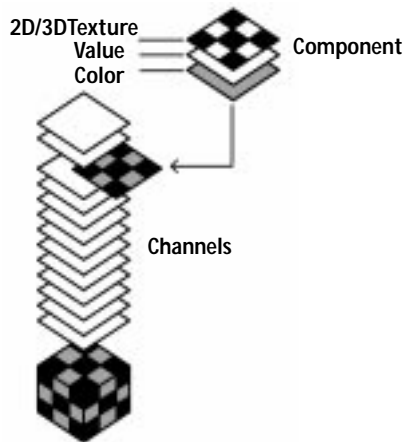

Each Bryce material channel contains components that determine its setting.

You can have up to three texture components in a channel, and some channels let you use four textures and a value as components.

Colors can only be used in the Diffuse, Ambient, Specular Transparent, Specular Halo and Volume channels. Values are used in the Diffusion, Ambience, Specularity, Metallicity, Bump Height, Transparency, Reflection, Refraction, Base Density, Edge Softness, Fuzzy Factor, and Quality/Speed channels.

When you're using a texture as a component, the information in the texture's channels is used as the value of the material channel. For example, if you're using a texture to set Diffuse Color, the texture's color channel is used. If you're using a texture to set the Diffusion value, the texture's alpha channel determines the Diffusion intensity.

Components are combined using one of three modes: Mode A, Mode AB and Mode ABC. In Mode A, only one component is used to set the channel's value. In Mode AB, two components are combined to set the channel's value, based on altitudes. The values from texture A are applied at low altitude and values from texture B are applied at higher altitude.

In Mode ABC, the values of two textures, A and B, are blended based on the alpha channel of texture C.

When you're using textures as a component you can choose from a number of preset textures, or you can open the Texture Editor and create your own textures. Refer to "Combining Components" on page 219 for more information.

In some channels, you can use both a texture and a value. In this case, the value determines how much of the texture's value is used to drive the channel. For example if you apply a Blue

Checkers texture to the Bump Height channel, the texture sets the shape of the bumps and the value sets how prominent those bump appear.



In this example the shape of the bumps on the object is set by the texture component in the Bump Height channel, but the height of those bumps is set by a value.

A Word About Alpha Channels

One of the outputs a texture component can produce is an alpha channel. The alpha channel is a grayscale representation of the texture pattern or grain. When you use a texture as a component in a material channel, these grayscale values are used to map surface properties. White areas in the alpha channel represent 100% of the effect and black represents 0%.

Images, or 2D textures, also contain an alpha channel. In images, the alpha channel acts as a mask for the image. The image's alpha channel is used in the same way as a texture's alpha channel.

Surface Material Channels

This section provides details on each of the surface material channels.

Diffusion

Diffusion determines how much direct light is reflected diffusely, or scattered, in all directions.

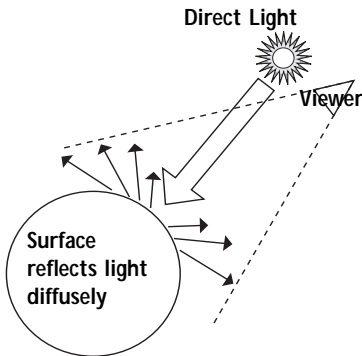

The small arrows projecting off the surface of the object illustrate how Diffusion works.

When light hits an object with diffusion set to 100%, all the light that hits it is reflected back scattered in all directions. This gives the object a flatly lit appearance. If the object's diffusion is set to 0%, no light is reflected off its surface, so the object appears black.



Diffusion set to 0%



Diffusion set to 100%

Diffusion controls how much light is diffusely reflected off the object's surface.

Setting Diffusion Using a Texture

When you assign a texture to the Diffusion channel, the texture's alpha channel determines which areas of the surface have high diffusion and which have low diffusion. Bright areas in the alpha channel have a high diffusion value and darker areas have low diffusion values.

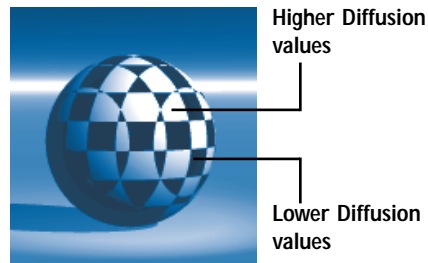

When you use a texture to set the Diffusion channel, the grayscale values in the texture's alpha channel determine the diffusion of the objects.

Diffuse Color

Diffuse Color acts like a filter through which all diffuse light passes. When light hits the object, the amount of light that's reflected diffusely is determined by the Diffusion channel setting, and the color of that light is set by the Diffuse Color channel.

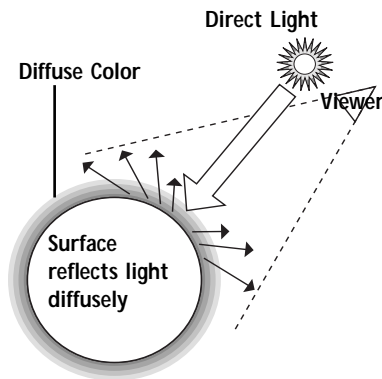

This graphic shows how diffuse light passes through the Diffuse Color.

When Diffusion is set to a value greater than zero, the Diffuse Color appears wherever the object is hit by direct light.

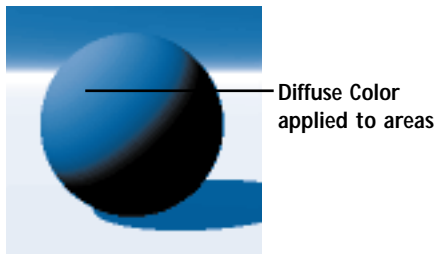

Diffuse Color is the color of diffusely reflected light.

Be careful when using pure constant colors as the Diffuse Color because you may not get the results you're expecting. If you use a pure color, only that color is reflected off the object. So if you're using 100% green, only green light is

reflected off the surface. This doesn't cause a problem when the object is hit by white light because there is green in white. However, if you use 100% red light on the object, it will appear black, since there is no green in 100% red, so no light is reflected off the object.

Try to avoid using pure colors for the Diffuse Color, so that your object always reflects some color.

Ambience

Ambience simulates the effects of light hitting the object from all directions. The Ambience value controls the amount of light that is reflected off the surface uniformly.

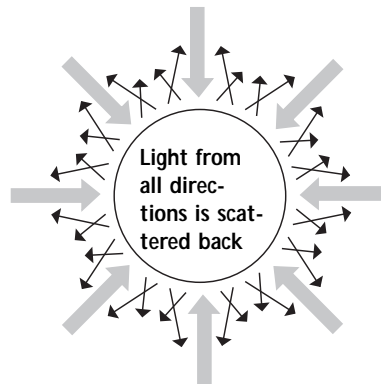

The large arrows represent ambient light hitting the object's surface. The smaller arrows represent the light reflected off the object's surface.

When Ambience is set to a value higher than zero, the object will reflect light from all over its surface, not only from the area hit by light. This makes the object look brighter.

The higher the Ambience value, the brighter an object appears. At 100%, the object appears unnaturally bright, regardless of the light source. If you want to create a realistic effect,

the sum of the Ambience and Diffusion values should add up to 100.



Ambience set to 0%



Ambience set to 100%

Ambience controls the general brightness of an object.

An object's ambience is directly related to the general ambience of the environment. So, the ambient value you set for the object is directly affected by the Ambient Color you set in the Sky & Fog palette.

The Ambient Color in the Sky & Fog palette controls how much ambient light is available in the environment. The Ambience channel controls how much of the available ambient light is reflected off the object's surface.

So, if you set the Ambient Color in the Sky & Fog palette to black, or 0% ambience, then the Ambience channel value has no effect. If you set the Ambient Color to white, or 100% ambience, the Ambience channel value will control how much of the available light is reflected off the object's surface.

Setting Ambience Using a Texture

When you assign a texture to the Ambience channel, the grayscale values from the texture's alpha channel determine which areas of the surface have high ambience and which have low ambience. Bright areas in the alpha

channel have high ambience values and darker areas have low ambience values.

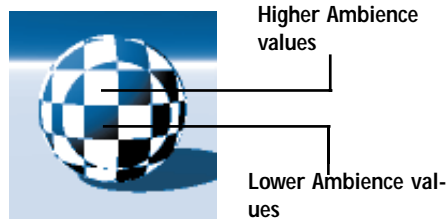

When you use a texture to set the Ambience channel's value, the values are determined by the grayscale values in the texture's alpha channel.

Generally, it's best to set Ambience using a value. However, you can get some interesting effects using textures instead. For example, if you use a splotchy texture, you'll get areas of your surface that appear to glow regardless of external light, mixed in with normal surface areas.

Ambient Color

Ambient Color is the color that is reflected off the surface of an object regardless of where the light source hits it. The Ambient Color is directly linked to the Ambience channel setting. If the Ambience is set to zero, the Ambient Color is invisible.

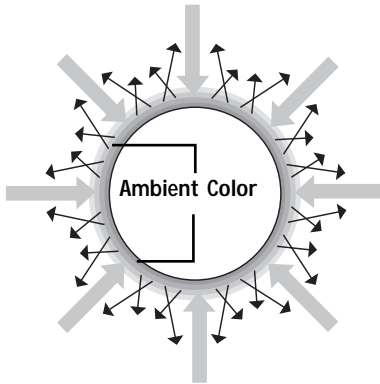

Ambient Color is the color that reflects off the entire surface of the object and is directly related to Ambience.

The Ambient Color tints the entire surface of the image.

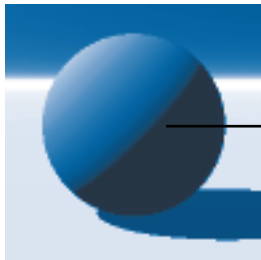

Ambient Color tints the entire surface

Ambient Color is the color that appears no matter where light strikes the object.

The Ambient Color channel is also related to the ambient color you set in the Sky & Fog palette. The ambient color of the environment is added to the ambient color of the object, so if your environment is blue and your object's

ambient color is yellow, your object appears green.

Setting Ambient Color Using a Texture

When you assign a texture to the Ambient Color channel, the color channel in the texture is used as the Ambient Color. In other words the texture's color is applied to any area of the object that's in shadow.

Specularity

Specularity controls how much light is reflected back from the surface of the object at the viewer.

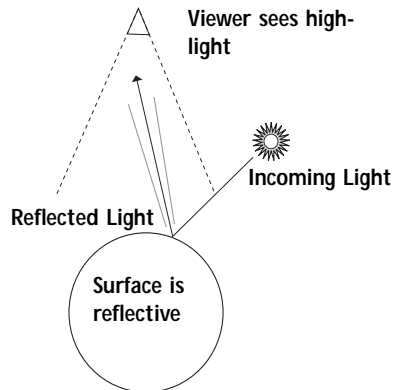

Specularity is the highlight reflected back at the viewer.

Since the direct reflection creates a highlight on the object, you can think of Specularity as the channel that determines the intensity of the highlight that appears on the object, or the "shininess" of the object.

The higher you set the Specularity, the shinier the object appears. When the Specularity is set to zero, the object appears dull.



Specularity set to 0%

Specularity controls the intensity of the highlight of an object.



Specularity set to 100%

However, using Specular Color you can set a specific color for your highlight.

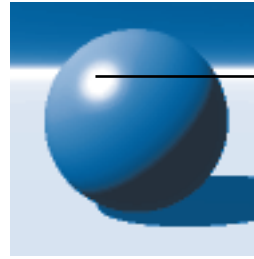

Specular Color applied to object's highlight

Specular Color is the color of the object's highlight.

Setting Specularity Using a Texture

When you assign a texture to the Specularity channel, the grayscale values in a texture's alpha channel are applied to the object's highlight. Bright areas of the alpha channel increase the intensity of the highlight, and darker areas decrease the intensity. The alpha channel may also create patterns in the highlight.



High Specularity values

Lower Specularity values



Alpha Channel

When you use a texture to set the Specularity channel's value, the highlight's intensity is determined by the texture's alpha channel values.

Specular Color is directly linked to the Specularity channel. If the Specularity is set to zero, the Specular Color is invisible.

By adding Specular Color you can make it appear as though a colored light is shining on the object.

Setting Specular Color Using a Texture

When you assign a texture to the Specular Color channel, the texture's color channel is used as the Specular Color. In other words the texture's color is applied to the object's highlight.

Specular Halo

The Specular Halo channel lets you control the size of the Specular highlight.

The size is controlled by the luminance value of the component you select. Brighter colors

Specular Color

Normally, the color of an object's highlight would reflect the color of the light source.

create larger highlights and darker colors create smaller highlights.



Specular Halo set using bright colors



Specular Halo set using dark colors

Specular Halo controls the size of the highlight on your object.

Colors are expressed as RGB (Red, Green and Blue) values. Specular Halo channels use the values from each of these channels to set the size of the highlight. If the values are all in balance (that is, all the same), the highlight appears uniform. However, if one value is higher than the rest (for example, R=200, G=100, B=100), you'll get a highlight with a slightly colored ring (for example, a red ring).



Specular Halo with balanced color



Specular Halo with varied RGB values

When you use a balanced color as the Specular Halo, you get a uniform highlight. If you use a color with varied RGB values, slight rings appear on the highlight.

Depending on the component you use in this channel, you may be able to set each color value differently to create different highlight effects. The easiest way to use this channel is with a color.

When using a color, try picking more desaturated colors. These colors produce more

predictable results because the difference between RGB values is less.

Check out the Specularity Lesson series in the Fast & Simple category in the Preset Materials Library to see Specular Halo in action.

Setting Specular Halo Using a Texture

When you assign a texture to the Specular Halo channel, the RGB value of the texture's color channel is used for the Specular Halo.

Metallicity

The Metallicity channel value acts as a filter for reflected light. This value controls how much of the reflected light is filtered through the Diffuse Color.

At 50%, half the reflected light is tinted with the Diffuse Color; at 100%, all the light that's reflected is tinted.

Metallicity is linked to Reflection. If Reflection is set to zero, the Metallicity channel has no effect.



Metallicity set to 50%



Metallicity set to 100%

Metallicity controls how much of the reflected light is tinted with the Diffuse Color.

Metallicity makes objects look metallic because it tints the color of reflections. If you want to create specific types of metals you need to adjust the Diffuse Color. For example, to create gold use a yellow Diffuse color.

Setting Metallicity Using a Texture

When you apply a texture to the Metallicity channel, the texture's alpha channel is used to determine the intensity of the Diffuse Color. Lighter areas of the alpha channel increase the intensity of the color, and darker areas decrease the intensity.

Bump Height

The Bump Height controls the height of bumps in an object's surface. The bumps on an object's surface are determined by the texture's Bump channel. The Bump Height channel is linked to the Bump channel in the texture. If you use a texture without a Bump channel, this channel has no effect. You can enter negative values in this channel, which turns bumps into dents.



Bump Height set to



Bump Height set to

Bump Height controls the height of bumps on the surface of your object.

Transparency

The Transparency channel controls how much light can pass through the object's surface.

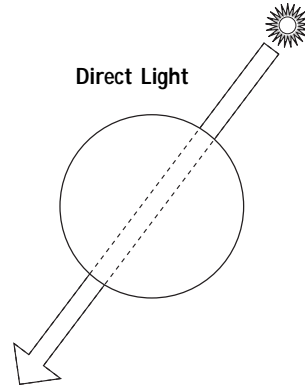

The amount of light that can pass through an object's surface is set with the Transparency channel.

The higher the Transparency value, the more of the surrounding environment is visible through the object's surface. If there is no other light being reflected, an object set at 100% Transparency appears invisible.



Transparency set to 0%



Transparency set to 100%

Transparency controls how much of the surrounding environment is visible through the object's surface.

To create a realistic transparent object, you need to pay attention to details. You'll need to combine the effects of the other channels to simulate a realistic object. For example, transparent bubbles all have highlights, so you'll need to add Specularity. Balloons have a flatter surface so you'll need to add more

Diffusion to the surface. Glass has a refraction effect associated to it, so you'll need to add Refraction to the surface.

Setting Transparency Using a Texture

When you apply a texture to the Transparency channel, the texture's alpha channel is used to determine which areas of the object are transparent. Lighter areas of the alpha channel are not transparent while darker areas are.

You can create some interesting effects using textures. For instance, a checkerboard texture will result in an object that's alternately transparent and solid. The final look of the Transparency channel is determined by the Shading mode. When the material is applied using normal shading, Transparency creates an optical effect.

When the material is applied using Blend Transparency mode, Transparency creates a punch-out effect. The areas of the surface that are 100% transparent are completely ignored during shading so that they appear as gaps or holes in the surface. Any areas that are less than a 100% result in a normal transparency effect.

Refer to "Shading Modes" on page 221 for more on Shading modes.



Cage texture applied to Transparency channel

You can create some interesting effects using textures in the Transparency channel, like this checkerboard object. This example was created using regular shading.



This is what the same material looks like when you use Blend Transparency.

Transparent Color

The Transparent Color channel determines the color of the transparent areas of your object. Light is filtered through this color as it passes through the object's surface. As a result, anything you can see through your object is tinted with the Transparent Color you select.

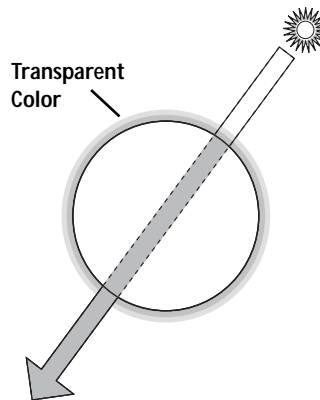

Transparent Color tints any light that passes through the object.

Keep in mind that the Transparent Color interacts with the other colors in the material. If the Diffuse Color is white, then the Transparent Color takes precedence. If the Diffuse color is yellow, and the Transparent color is red, the object appears orange. However, when you're using Refraction, the

Transparent Color blends with the Diffuse Color.



Transparent Color applied to the object

The Transparent color tints everything you see through the surface of your object.

Transparent Color is linked to the Transparency channel. If the Transparency is set to zero, the Transparent Color is invisible.

Setting Transparent Color Using a Texture

When you assign a texture to the Transparent Color channel, the texture's color channel is applied to the transparent areas of your object.

Refraction

The Refraction channel determines whether light bends when it passes through the surface of an object.

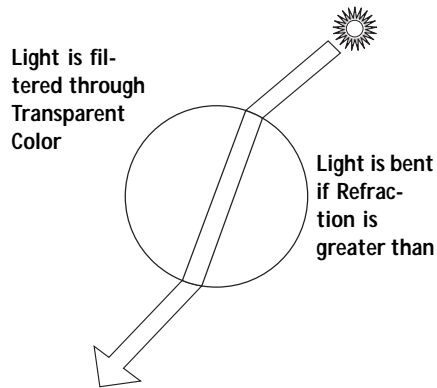

Light may bend as it passes through an object, depending on the Refraction value.

Higher Refraction settings produce slight reflections as some of the light is bent directly back at its source. Higher Refraction settings also change the color of the object's surface as the colors reflected from the environment affect the object's color.



Refraction set to 0



Refraction set to 116

Refraction controls how much light bends as it passes through a transparent surface.

The Refraction value is what makes transparent surfaces look like glass.

As you increase the Refraction value, the edges of the object will become reflective. This simulates the effect of light being refracted so

sharply that it does not penetrate the object's surface.



Refraction set to 140



Refraction set to 300

In these examples you can see how the edges become more reflective as you increase the Refraction value.

The higher you increase the Refraction value, the more the Diffuse Color is blended with the Transparent Color. The higher the value, the more Diffuse Color is visible in the object's surface. Any light that's visible through the surface of the object is then tinted through both the Diffuse Color and the Transparent Color.

Refraction values are expressed as 100 x Refraction Index value. The Refraction Index contains refraction values for specific types of surfaces. For example, the Refraction Index of water is 1.3; this value is expressed as 130 in the Materials Lab.

Refraction is linked to Transparency. If Transparency is set to zero, this channel has no effect.

Setting Refraction Using a Texture

You cannot use a texture to set the value of the Refraction channel. You can only use a value to set this channel.

Reflection

The Reflection channel controls how much light, direct or indirect, is reflected off the object's surface. Unlike Diffusion, which

scatters light, Reflection directs light back at its source, giving the object a mirrorlike appearance.

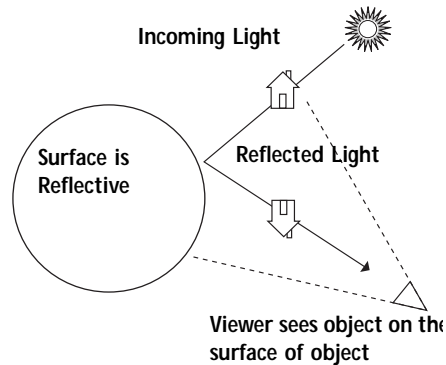

Reflection determines how much light is reflected off the surface of the object.

The higher the Reflection setting, the more reflective the surface. At 50%, half the light that hits the object's surface is reflected, at 100% all light is reflected.



Reflection set to 50%



Reflection set to 100%

Reflection controls how much light is reflected off the surface of an object.

As you increase the Reflection value, the color of the object changes, since you can see more of the environment in the object's surface.

Setting Reflection Using a Texture

When you apply a texture to the Reflection channel, the texture's alpha channel is used to

determine which areas of the object are reflective. Lighter areas of the alpha channel are reflective, while darker areas are not.

Volume Material Channels

Volume materials use most of the same channels as surface materials. These channels all work the same as they do for surface materials. The only difference is that the channels control the properties of the object's volume, not its surface.

In addition to the channels already discussed, Volume materials have several specialized channels.

Volume Color

The Volume Color channel controls the color applied to the interior of an object. Everything inside the object will appear tinted with this color as all light is filtered through the Volume Color.

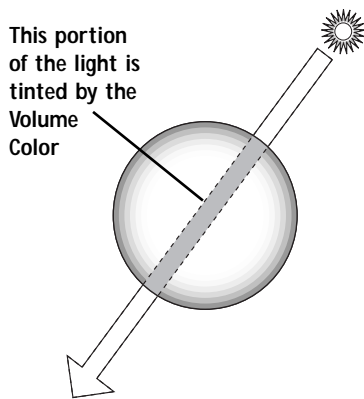

The interior of an object can have color, which you set with Volume Color.

The Volume Color interacts with the Transparent Color. If your surface is transparent, light is tinted by the Transparent Color and the Volume Color.



The Volume color tints everything inside the object.

Volume color is an excellent way of creating underwater light effects.

Base Density

Base Density controls how dense the object is. In areas where the object is very dense, no light passes through the object. Where the object is less dense, more light passes through its volume. Base Density works like Transparency in 3D space. Areas that are less dense appear to be more transparent.

High values create very solid objects like rocks, while lower settings create less dense objects like clouds.



Base Density set to 100



Base Density set to 0

Base Density controls the density of the area within an object. Objects with a low density will appear more transparent.

You should use this channel cautiously. The more transparent objects are, the more time they take to render.

Setting Base Density Using a Texture

When you use a texture to set this channel, the alpha channel is used to determine which areas of the object are solid and which are empty.

Edge Softness

Edge Softness controls the softness of the edges of the silhouette of objects with a volume material. For example, a sphere with a low Edge Softness value will have a “hard” silhouette, meaning that you’ll be able to clearly see the edges of the sphere. A high Edge Softness value will almost totally obscure the edges of the sphere.



Edge Softness set to 0



Edge Softness set to 100

Edge Softness controls the softness of an object’s silhouette.

This channel is useful for obscuring the general shape of an object. Use this effect if you want to blur the overall shape of the object to which you’re applying the material.

Fuzzy Factor

Fuzzy Factor controls the dullness or sharpness of a material. Values greater than 100 adjust the dullness of the material, and values less than

100 adjust the sharpness of a material. At 100 there is no dullness or sharpness applied



Fuzzy Factor set to 0



Fuzzy Factor set to 200

Fuzzy Factor controls dullness/sharpness of the texture within your object.

As you increase the dullness of your object, it becomes less dense, so you may have to increase the Base Density to compensate. Likewise, as you increase the sharpness of the object it becomes more dense.

You can use this channel to smooth sharp-looking clouds, or sharpen dull stone textures.

Quality/Speed

Quality/Speed controls the render quality of the texture. This channel represents the inverse relationship between render quality and rendering speed. As you increase the render quality of the material, you decrease the speed at which it is rendered. As you increase the speed at which a material is rendered, you decrease its quality.



Quality/Speed set to set to 0



Quality/Speed set to set to 100

The Quality/Speed value controls the quality of the texture’s render in relation to how fast it renders.

The material loses detail as the quality decreases. Detail is introduced as it increases.

For still images you probably want to increase the quality of the material and sacrifice speed, since the scene only has to be rendered once. For animations, you probably want to sacrifice quality since the scene will have to be rendered once for each frame in the movie.

Material Components

This section describes the various components you can use to set a material channel value. It also describes how to set the parameters for each component.

Color Components

A color component is an RGB color that is directly applied to a channel. Colors can only be used in the Color channels: Diffuse, Ambient, Specular, Specular Halo, and Volume.

When you're using a color in these channels you cannot combine it with a texture. If you choose a texture component for any of the Color channels, the color oval appears blank. The Volume channel can only be set with a color.

To use a color as a component:

- 1 In the Materials Lab, click the color oval in one of the channel rows on the Material Grid and choose a color from the palette.

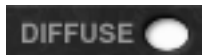

The Color oval in the channel column displays the color palette.

- To choose a color using the Color Picker, hold down Option/Alt when you click the color oval.

The selected color appears in the color oval. If you click on one of the columns, the color oval appears blank.

Value Components

Value components are numerical values you use to set the intensity of a channel. Values can only be used in the Value, Optics or Volume channels.

A value is indicated by either the numerical field in the left side of the channel in the Material Grid, or the slider that extends out from the channel. The sliders let you quickly set the value of a channel and the numeric field shows the current setting.

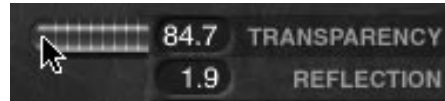

The value slider in a channel lets you set a numerical value for the intensity of the channel and displays the channel's current setting.

Values can be used with textures. In this case the value sets how much of the texture is applied to the channel. For example, if you use an orange-colored texture to set the Diffuse Color channel, the value would indicate how much of the texture color is used as the Diffuse Color.

A value of 100 means that all the texture information is used in the channel; a value of 0 means that none of the texture is used.

Not all channels use values. The Color channels only use colors or textures. The Refraction channel can only be set with a value.

To use a value as a component:

- In the Materials Lab, drag the slider next to the channel whose value you want to set. As you drag, the numerical value appears in the number field.
Some channels let you set negative values.

Texture Components

When you use a texture as a component, Bryce extracts values from the texture to use as a value for the material channel. There are two types of texture components you can use: pictures and 3D textures. Pictures are images you import from either the Picture Library or from another application. 3D textures are procedural textures generated by Bryce and stored in a texture library.

You can assign up to four textures as components for a material. These textures can be any combination of pictures and 3D textures. Each texture component is assigned a letter: A, B, C, or D.

The texture you assign to a component is used throughout the material, so the texture you assign as component A in the Diffusion channel is the same component A used in the Ambience channel and so on.

When you're setting channel values, you can mix and match components. For example, you can assign component A to Diffusion and component D to Ambience. You can also combine textures within the same channel using the blend modes AB and ABC. In this case the texture you assigned to A is blended with the textures assigned to B and C to set a material channel value. Refer to "Combining Components" on page 219 for more on blend modes.

The Texture Component Window

The Texture Component window displays the attributes of a selected texture component. You can have up to four windows visible in the Materials Lab.

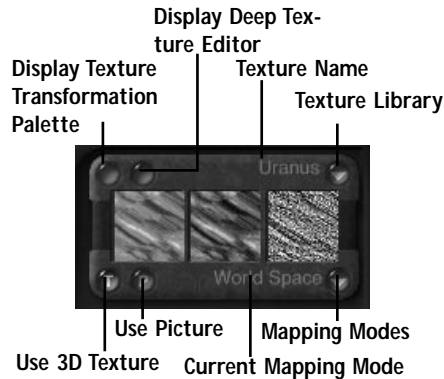

The Component window displays the selected component and its current attributes.

The six buttons on the Texture Component window let you set the type of component, the texture mapping mode, access the texture transformation controls and the Deep Texture Editor.

To use a Texture as a component:

- Click a column in the material grid. A Texture Component window appears.
The component window corresponds to the columns in the grid, so if you click column A in the grid, texture component A becomes active.

3D Textures

3D textures have three different types of outputs: Color, Alpha channel and Bump. These outputs are used differently by the material channels.

Color channels use the texture's color to set the value of the channel. For example, if you use a texture in the Diffuse channel, the colors in the texture appear wherever the object reflects light diffusely.



Diffuse color set using a color

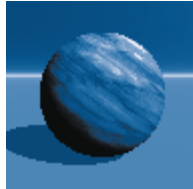

Diffuse color set using a texture

When you use a texture to set the value of a Color channel, the color information is used to set the material channel value. In this example, the Diffuse color was set using a texture.

Value, Optics and Volume channels use the alpha channel information from a texture to set the value of the material channel. For example, when you use a texture to set Specularity, the texture's alpha channel information determines which areas of the object are shiny. As a result, you'll see the pattern of the texture on the object.



Specularity set using a value

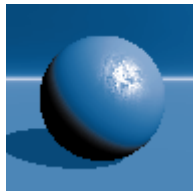

Specularity set using a texture

When you use a texture to set the value of an Intensity channel, the alpha channel information is used to set the material channel value. In this example, Specularity was set using a texture.

The Bump information in a 3D texture is used only by the Bump Height channel. The Bump channel in the texture determines the pattern of bumps or dents in the object. In fact, you won't be able to see the effects of the Bump

Height value unless you assign a texture to the channel.



Bump Height set using a value



Bump Height set using a texture

Bump channel information from a texture is used to determine the pattern of bumps or dents in an object. You must assign a texture to the Bump Height channel to see the bumps or dents.

To use a 3D texture as a component:

- 1 In the Materials Lab, click a channel column.

A randomly selected texture appears in the Component window.



When you select 3D texture as a component, the Component window displays a randomly selected texture in the preview area and shows the texture's current attributes.

- 2 If you want to change this texture, click the triangle button next to the texture name at the top of the window and choose a preset texture from the menu.

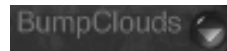

The triangle button next to the 3D texture's name in the component window provides access to all the preset 3D textures available in Bryce.

The texture you selected appears in the Component window.

2D Textures

2D textures are pictures you've created in another application or ones you select from the Pictures Library. The data in the channels of these pictures are used as values in the material channels.

To use a 2D texture as a component:

- 1 In the Materials Lab, click a channel column. A texture appears in the texture component window.
- 2 In the Component window, click the P button at the bottom of the Component window.



The P button changes the component to a 2D picture.

A default picture appears in the Component window.



When you select 2D texture as a component, the Component window displays a default picture in the preview area and shows the picture's current attributes.

- 3 To change the picture, click the pink button at the top of the component window.



The pink button displays the Pictures Library.

The Pictures Library appears.



The Pictures dialog lets you select a 2D image to use as a Pict object.

- 4 Click an image square to load an image.
 - 5 If the image you want is not in the library:
 - Click the Load text button. The Load Image dialog appears.
 - Use the dialog controls to locate the picture you want to use and click Open.
- or
- In another application, copy the picture you want to use to the Clipboard.
 - Access the Picture dialog and click the Paste text button.

The picture is loaded into the first image box and its alpha channels are loaded into the second box.



When you load a new picture into the Picture dialog, the main image is loaded into the first box and its alpha channel is loaded into the second box.

You can invert the alpha channel by clicking the invert button.



- 6 Click the OK icon to exit the dialog.
The picture appears in the Component window.

Using the Pictures Editor

The Pictures Editor in Bryce has three squared previews, at the top of the window. These three previews represent one image, three different ways. The left image is the RGB information of the image, the middle one is the alpha channel, right is the combined image. You can apply filters to each of the three parts independently.

How to select a plug-in folder:

- Click on the triangle to the right of the desired preview type.
If a plug-ins folder has been previously selected, a pull-down menu appears that displays the available Photoshop filters.
- If, for some reason, the Photoshop filters cannot be found, or you wish to select a new plug-ins folder, select Select Plug-ins Folder at the bottom of the menu.
Select a folder for the plug-in.

How to add blank images into the library:

- 1 Click on the New button at the upper right of the Pictures Editor.
The New dialog appears.
- 2 Enter a name for the image as well as the resolution and default color.

- 3 Click the checkmark to return to the Pictures Editor.

The Pictures Editor will contain the new image in one of the tiles.

Once the picture is available in your library, you can load different alpha channels or different RGB information. You can also run any Photoshop filter on either of the two components of this image or the entire image.

How to apply filters to pictures:

- 1 Select a picture from the picture tiles.
The picture appears in the top preview frames of the picture editor.
Select a plug-in from the currently selected plug-in folder.
- 2 Select a plug-in from the folder.
- 3 The filter is applied to your image.

Texture Mapping Modes

Once you've decided on a texture to use as a component, you need to decide how the texture is mapped onto your object. The appearance of the texture can change dramatically depending on how it's applied to the object.

Each texture you apply can have a different mapping mode. When you're mixing textures (Mode AB or Mode ABC), you can choose which portions of your textures you want to combine.

To select a mapping mode for a texture:

- 1 In the Materials Composer, click a channel.
- 2 Select a mode for the channel.
- 3 Click the title of the Component window and choose either 2D Texture or 3D Texture.

- 4 Click the current Mapping Mode title and choose a mapping mode from the menu.

Object Space

In this mode, textures are scaled proportionally to the size of your object. If you change the size of your object, the texture scale changes with it. The texture also rotates along with the object. This means that the texture does not appear to move as you reposition or rotate the object.

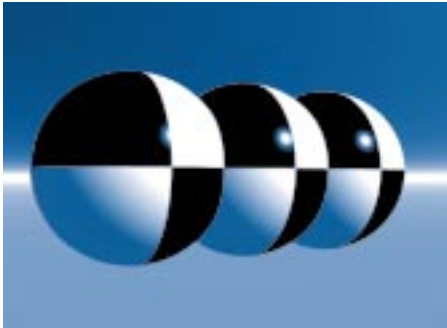

In Object Space mode, textures are applied to the object so the texture will not move as you move the object.

World Space

In this mode, the texture is infinitely large 3D space, and only a small portion is applied to your object. This means that the texture appears to change as you move your object,

since it is moving through the texture in 3D space.

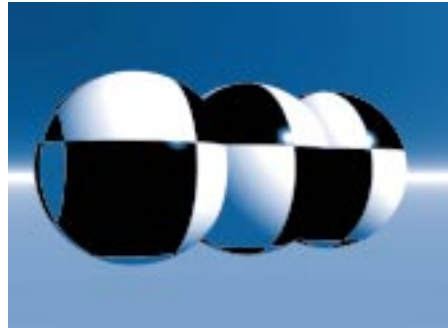

In World Space mode, the texture is applied to the entire world, so the texture appears to move as you move the object.

Parametric

In this mode, the texture is applied onto the object as if it were a decal. For example, if you use this mapping mode on a cube, one iteration of the texture is placed on each face.



Parametric mode applies the texture as a 2D decal.

The texture is mapped onto the object so it rotates and scales as the object is scaled or rotated.

This mode works best with 2D Pict textures.

Parametric Scaled

This mode works like the World Space mode, only in 2D. Textures mapped using this mode are not scaled with the object.



Parametric Scaled mode applies the texture as a decal, but does not scale the texture as you scale the object.

Use this mode when you want to map a 2D picture onto constructed objects like buildings.

World Top

In this mode a 2D projection of the texture is applied to the object from directly above it. If you move your object or rotate it, the texture does not move with the object; it remains constant while the object moves through it.



World Top mode applies the texture to the top of the world. The texture appears as a projection on top of the object and streaks down its sides.

Spherical

In this mode, a 2D projection of your texture is mapped onto a virtual sphere that surrounds your object. It is then projected from the sphere onto your object.



Spherical mode applies the texture to a virtual sphere and then projects it onto your object.

Cylindrical

In this mode, your texture is mapped onto the front of your object, wrapping around the right and left sides all the way to the back. Edge pixels going to the center appear on the top and bottom of your object.



Cylindrical mode wraps a texture around the object starting from the front.

Reflection Map

In this mode, a 2D projection of your texture is applied to a virtual sphere that surrounds your scene. The texture is then reflected off of the sphere and onto your object.



Reflection Map mode applies a reverse image of your texture to your object.

This mode works best on objects with irregular surfaces. It also works well with terrains.

Random

This mode randomly applies a 2D projection of the texture all over the surface of your object.



Random mode applies the texture all over the object in a random pattern.

Object Top

This mode applies a 2D projection of the texture to the top of your object. The texture rotates and scales along with the object.



Object Top mode applies the texture to the top of the object.

Object Front

This mode applies a 2D projection of the texture to the front of your object. The texture rotates and scales along with the object.



Object Front mode applies the texture to the front of the object.

Mapping Mode Modifiers

You can modify the mapping modes in the following different ways.

Symmetrical Tiling

When you tile a texture onto an object in symmetrical tiling mode, each repeated instance of your texture is tiled horizontally and vertically, as needed to seamlessly produce a symmetrical pattern over the surface of the object.



in Symmetrical Tiling mode, textures are seamlessly tiled across the object.

Repeat Tiling

Unlike symmetrical tiling, in which a seamless tiled pattern is achieved by flipping the texture horizontally and vertically, Repeat Tiling repeats your texture across the surface of your object without any alteration in orientation. The number of instances of the texture depends on the scale applied to the texture.

Scale Pict Size

This mode modifier only affects picture textures. When selected, the image behaves like a sticker placed on the surface of the textured object. Unless Scale Pict Size is selected, the

picture will repeat itself across the surface in a similar way to Repeat Tiling.

Centered Transforms

Centered transforms works with parametric mapping modes to force the transformation of the textures to be applied around the center of the object surface.

Decal Colors

Decal colors blends the color of a texture with the affected component's base color. It uses the texture's alpha channel to control the amount of blending. This can make decalomania effects easier to achieve.

Alpha Scaling

Normally, if you drive a component's value with a texture, the texture's alpha channel will set the value without regard to the amount that was set using the component's slider. With alpha scaling turned on, the amount set with the slider will "scale" the amount provided by the texture's alpha channel. This gives you more subtle control over the influence of the texture on the material component's value.

Transforming Textures

Since a 3D texture exists in three-dimensional space, it can be transformed along the X, Y, or Z axis—just like a 3D object. Using the texture transformation tools, you can scale, position or rotate your texture.

The final look of the transformation depends on the mapping mode you use to apply the texture to the object. In some modes, texture transformations may not be very noticeable, while in others, like Parametric, transforms can have a large impact on the look of the material.

You may find it necessary to experiment with different settings to get the results you want. If you find that the texture isn't reacting the way you want it to, try changing the mapping mode. Refer to "Texture Mapping Modes" on page 212 for more on mapping modes.

The transformation tools give you very fine control over the final appearance of the texture.

Scale

Using the Scale tool, you can control the frequency of the texture. Increasing the scale of a texture decreases the frequency of the pattern, since it doesn't have to be repeated as many times to cover the surface of the object.



Scale X=0% Scale X= 50% Scale X=100%

Since a 3D texture exists in 3D space, you can change its size in all three axes. Adjusting the scale in X changes the size of the texture along the X axis.



Scale Y=0% Scale Y= 50% Scale Y=100%

Adjusting the scale in Y changes the size of the texture along the Y axis.



Scale Z=0% Scale Z= 50% Scale Z=100%

Adjusting the scale in Z changes the size of the texture along the Z axis.

Rotation

Using the Rotation controls you can control the angle of the texture on the object's surface. You can create very different texture effects depending on its orientation.



Rotation X=0° Rotation X=90° Rotation X=180°

Since a 3D texture exists in 3D space you can change its orientation in all three axes. Adjusting the rotation in X changes the angle of the texture along the X axis.



Rotation Y=0° Rotation Y=90° Rotation Y=180°

Adjusting the orientation in Y changes the angle of the texture along the Y axis.



Rotation
Z=0° **Rotation**
Z=90° **Rotation**
Z=180°

Adjusting the orientation in Z changes the angle of the texture along the Z axis.

You can transform a texture numerically by adjusting the X, Y and Z coordinates or interactively using the transformation tools.

Position

Using the Position controls, you can control where the texture appears on the object's surface. When you're using a picture as a component, placement can be vital to the look of the material. For example, if you're placing a decal on an object, use the Position controls to precisely place the image in the center of the object or on the correct face.



Position **Position** **Position**
X=100 BU

Since a 3D texture exists in 3D space you can change its position in all three axes. Adjusting the position in X changes the placement of the texture along the X axis.



Position **Position** **Position**
Y=50 BU Y=100 BU

Adjusting the position in Y changes the placement of the texture along the Y axis.



Position **Position** **Position**
Z=100 BU

Adjusting the position in Z changes the placement of the texture along the Z axis.

To transform a texture numerically:

- 1 In the Texture Component window, click the first button on the left at the top of the window.

The Transformation palette appears.



Use the texture transformation palette to adjust the scale, position and orientation of the texture component.

- 2 Move your cursor over the transformation you want to apply.
- 3 Drag the cursor over the value you want to adjust.

Drag left to increase the value or right to decrease it.

As you adjust the value, the material preview updates to show the results of your changes.



The material preview area updates as you transform the texture to show your changes.

- 4 Click the OK icon to apply your changes.

To transform a texture interactively:

- 1 In the Texture Component window, click the click the first button on the left at the top of the window.
The Transformation tools appear.
- 2 Move the cursor over the tool you want to use until the mode you want is active.
- 3 As you pass the cursor over the tool, the tool changes to display the different modes available.
- 4 Drag the mouse in the direction you want to move, scale, or rotate the texture.
- 5 Click the OK icon to apply your changes.

Editing Textures

You can edit the makeup of an existing texture or create a completely new texture using the Deep Texture Editor. This editor uses some rather complex texture-generation concepts to create textures for Bryce. You can either choose to learn all these concepts to create your textures precisely, or use the editor as a type of

lab where you combine random settings and see the results.

Refer to “Textures” on page 237 for more information about learning texture-generation concepts.

Combining Components

You can combine material components using one of three blending modes:

- Mode A
- Mode AB
- Mode ABC

Mode A

In Mode A, only one component is used to set the value of a channel. The component can be a value, a picture or 3D texture.

Mode AB

In Mode AB, two textures are blended together based on altitudes. At the lowest altitudes the values from texture A are used, at higher altitudes texture B is used to set the value of the channel.

Altitude is based on the distance between the ground level and the highest object in your scene.

When you use this mode, an object’s surface material is a blend between two texture components. Texture B appears at the bottom of the object and Texture A appears at the top. In between is a blend between texture B and texture A. Bryce creates the blend by interpolating between the two textures.

For example, if you use Mode AB in the Diffuse Color channel, the color in texture A appears at

the bottom of an object's surface, and the color from texture B appears at the top. A color gradient between color A and color B appears in the middle of the object

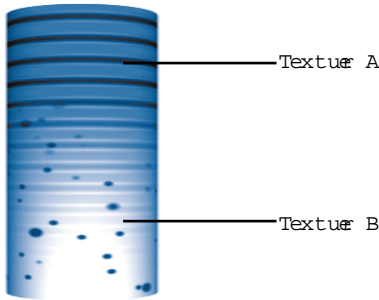

In this example, Mode AB was used to set the Diffuse Color channel. Values from texture A set the Diffuse Color channel at lower altitudes while values from texture B set the channel at higher altitudes.

Mode AB can be used to create snow covered peaks on terrains or murky depths in infinite water slabs.

To use mode AB to blend textures:

- In the Materials Lab, Control/Ctrl- click the B column of a channel.
Component indicators appear in both the A and B columns of the channel.



Component indicators in both the A and B columns of a channel indicates that you're using mode AB to blend texture components.

Mode ABC

In Mode ABC, two textures, texture A and texture B, are blended based on the alpha channel of texture C. In this mode the alpha channel from texture C acts like a map that tells Bryce where to apply the values from texture A and texture B. All the white areas of the alpha

channel use values from texture A; black areas in the alpha channel use values from texture B. Gray areas in the alpha channel use a combination of both textures.

Alpha Channel	Texture Used
	Texture A
	Combination of A and B
	Texture B

In the example that follows three textures were combined using Mode ABC in the Diffuse Color channel.

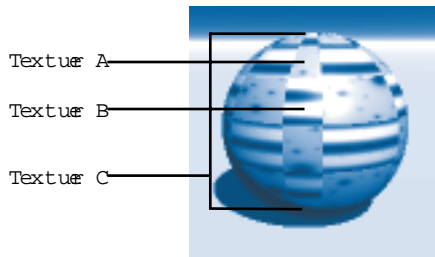

Using Mode ABC to combine the three textures, the spot texture (A) appears in the white areas of the checker texture's alpha channel (C) and the lines texture (B) appears in the black areas of the alpha channel.

To use Mode ABC to blend textures:

- 1 In the Materials Lab, Control/Ctrl- click the C column of a channel.

Component indicators appear in the A, B and C columns of the channel.



Component indicators in the A, B and C columns of a channel indicate that you're using Mode ABC to blend texture components.

Shading Modes

Shading refers to the process of applying material channel values to an object. When an object is shaded, the different values in the material are applied to the object. The shading modes available in Bryce determine how material channels are applied to create different effects.

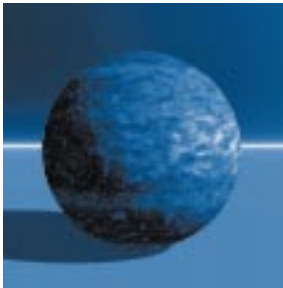

Using a material, you can define whether a surface is shiny, smooth, or opaque.



Using a shading mode, you determine how those properties are applied to the object.



The shading mode cannot only determine how the material is applied to the surface of the object, but how it's applied to its volume as well.

To choose a shading mode:

- Click the triangle icon next to the material type buttons at the top of the Materials Lab.

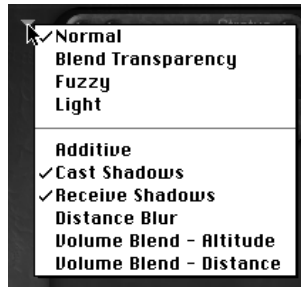

Click the triangle icon at the top of the Materials Lab to display a listing of the available shading modes.

Surface Material Shading Modes

This section explains the surface material shading modes.

Normal

Normal mode applies the values of the material without modifying them in any way. Objects are shaded according to the values you set in the material channels. This mode has no special effects; it simulates a real-world appearance using the material channel values.

This is the default mode and is appropriate for most objects.

Blend Transparency

In Blend Transparency mode, visibility is controlled by Transparency. When this mode is active, areas of the object that are 100% transparent are ignored. Transparent areas are not shaded and do not cast shadows. These areas appear as gaps or holes in the object's surface.

This mode lets you create punch-outs when using a texture.

Using Normal Shading



Using Blend Transparency Shading



This cage was created by using blend transparency to "punch-out" areas of the object's surface.

Anything less than 100% Transparency results in normal transparent areas.

Fuzzy

Fuzzy mode changes the effective Transparency based on the thickness of the object. As a

result, objects appear fuzzy on the edges and solid at the center.



When you apply a material using Fuzzy shading mode, the edges of the object appear blurred, while the center remains solid.

Since Bryce uses depth information to synthesize this blurry effect, it is not available for 2D objects such as Squares or Disks.

Use the Transparency setting to adjust the degree of fuzziness.

Light

Light is a very specialized shading mode best used to create visible lighting effects. Objects

shaded with this mode appear transparent and self-illuminating.



The Light shading mode is designed to create simple light effects. If you apply it to a cone object, it looks like a cone of light.

Only the Diffuse, Ambient and Transparent Color channels are used to determine the color of the light. All other channels are ignored.

This mode is useful for creating point lights without the rendering overhead that comes with true volume light objects (that is, light-sensitive volume materials).

Volume Material Shading Modes

This section explains the volume material shading modes.

Flat Shading

Flat shading mode is designed for clouds, gases and other self-luminous gaseous materials. Flat shading mode does not shade an object,

meaning that light sources have no effect on the color or brightness of the object.



The Flat shading mode applies your material as a volume material, but does not apply any shading.

When this mode is active, Diffusion, Ambience, Specularity, Ambient Color, Specular Color and Transparency Color have no effect.

The color of the material is determined entirely by the Diffuse Color channel.

Full Shading

Full shading mode is designed for hard edged, sharp objects like rocks. When Full shading mode is active, the visible portions of the material are shaded and can be affected by light sources.



The Full shading mode applies your material as a volumetric material, and applies shading to the visible portions of the material.

Since light sources can affect portions of your material, shadows will appear within the object. This can greatly increase rendering time. If you don't need to see shadows in the object, make sure the Receive Shadows filter is disabled. Usually you should disable this filter unless you're creating very specialized effects.

Light Sensitive

Light Sensitive mode is designed for creating visible light effects such as light beams. Light Sensitive mode does not shade objects, but the particles in your material are sensitive to light.

In this mode, Density doesn't control density as much as it sets the light sensitivity of material particles. Higher values create brighter particles and lower values create darker particles.

To get the best results for light objects, use the Additive blend mode.

The color of the particles is determined entirely by the Diffuse Color channel.

The result is like shining a light through a volume. If you were shining a light through a

cloud material, you would be able to see the clouds within the light cone.

When this mode is active, Diffusion, Ambience, Specularity, Ambient Color, Specular Color and Transparency Color have no effect.



Use Light Sensitive shading mode to create visible light effects like light beams.

Shading Mode Modifiers

Shading mode modifiers are not shading modes, but they modify an existing shading mode. When you select a modifier it remains enabled until you disable it. You can also apply more than one modifier at the same time.

Additive

When this modifier is active, material channels are applied to the environment behind the object instead of to the object's surface.

If you put an object on a bright background, it appears almost white. For best results, set your Ambient Color control to zero and render against a dark, plain background. Objects with

this shading mode modifier selected will not cast shadows.



When you modify a shading mode using Additive, objects appear as ghost images.

This mode is very useful for creating planets and quarter moons, light beams, and ghost images.

Distance Blur

This modifier is designed to minimize the problem created by highly bumpy textures fading into infinity (i.e., the horizon). Often, moiré-like patterns appear in these cases as the pixels try to resolve the infinitely receding high frequencies of bumpy water or grooved sand, and so on. The Distance Blur modifier fades the bumpiness well before it hits the horizon.

Receive Shadows

This modifier prevents an object's surface from accepting shadows cast by objects around it. The object itself will cast a shadow, but it won't accept them from other objects.



When the Receive Shadow filter is disabled, no shadows will appear on the object's surface.

Cast Shadows

This modifier prevents an object from casting shadows. The object's surface still reacts normally with light but it does not cast any shadows.

Self Shadows

This modifier prevents an object from casting a shadow onto itself, yet still shadow all the other elements of the scene.

Volume Blend-Altitude

This modifier gradually blends in the Volume color based on altitude. Areas at lower altitudes are tinted with the 100% Volume Color; as you

move higher up, less of the Volume Color is added.

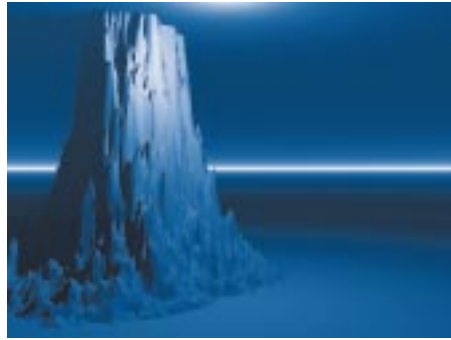

Using the Volume Blend-Altitude you can simulate the effects of sinking deeper into a volume of water. The lower you sink, the darker it becomes.

This modifier can be used to create a sense of depth in an infinite water slab. If you blend between a light Diffuse Color and a darker Volume Color, you can create the illusion of depth as you sink deeper into the water.

Volume Blend-Distance

This modifier blends the Diffuse and Volume Colors of your material based on the distance from the camera. Areas that are closer to the camera will be tinted less with the Volume

color. As you move further away, more of the Volume Color is visible.

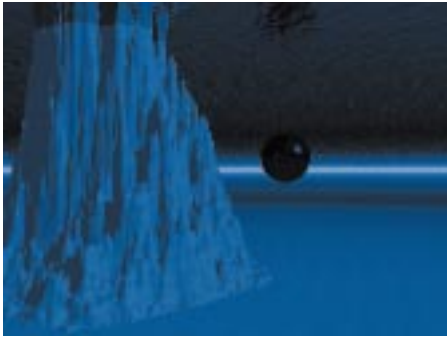

Using the Volume Blend-Distance you can simulate the effects of looking through murky water. Distant objects appear darker than closer ones.

This modifier is excellent for creating underwater depth effects. If you blend a darker Diffuse Color with a lighter Volume Color in an infinite slab, you can simulate the effects of murky water on distant objects.

The Materials Lab

The Materials Lab is where you create and edit your materials in Bryce. This unique editor lets you combine a wide variety of components and channels to create an infinite number of different surfaces and volumes.

To display the Materials Lab:

- 1 Create an object.

- 2 Select the object in the Working window. A number of object attribute icons appear to the right of the object.



Use the quick access buttons next to a selected object to access editors and get information about the object.

- 3 Click the M icon. Alternatively, you can choose **Objects menu > Edit Material** or display the Edit palette and click the Edit Material tool.

The contents of the composer depend on the material currently applied to the object. If there is no material, the default material's settings appear.

A Quick Tour of the Materials Lab

The Materials Lab is set up like a visual chart that lets you see all the different channels that make up your material. At a glance, you can see all the settings for each material channel and the texture components used to drive channel values.

In the top left corner is the mode toggle button. This button lets you switch between surface material and volume material. The buttons also indicate what type of material you're creating. Surface is enabled by default. When you toggle

to Volume, the channels in the lab change to display the volume channels.



Use the toggle button to switch between material types.

Material Preview Window

On the left side of the Materials Lab is the Material Preview. This little window shows you what your material will look like when its applied to an object. The preview updates as you adjust the channels.

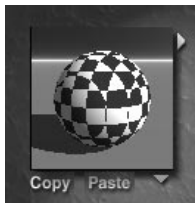

The Material Preview shows you what your material will look like when it's applied to an object. You can drag the preview to get a different view of the object.

The Materials Grid

The center of the Materials Lab is call the Material Grid. This is where you combine values, colors and textures to set channel values. The Materials Grid is divided into three

sections each containing logical groups of channels.



The Material Grid gives you a one-glance view of all the channels that make up your material.

The Color channels group contains all the material channels that define the colors that appear on the object surface when it's struck by light.



The Color group in the Material Grid contains all the channels that define the color of an object's surface or volume.

Each channel in the Color group has a color oval next to its title. This oval lets you quickly set a color for the channel.

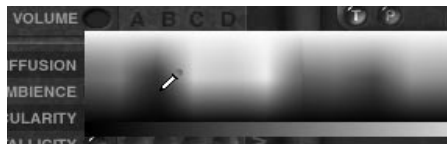

Use the Color oval to quickly set a color for the channel using the Color Picker.

The Value group contains all the channels that define how the object's surface or volume reacts to light. In other words, they control whether the object is shiny, metallic, bright or dark.



The Value group contains all the channels that define how an object's surface or volume reacts to light.

The Optics group contains all the channels that define any optical effects associated with the object.

When you're creating volume materials, the Optics group is replaced by the Volume group. This group contains all the channels that define the appearance of an object's volume.

All of the channels in these three groups have sliders on the left side of its row. The sliders lets you quickly set the value of the channel. Values can be used in conjunction with textures or on their own. In the case of the Refraction channel, you must use a value.

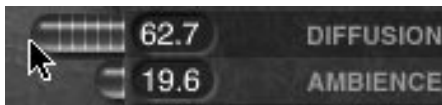

Use the value sliders to set a value for the channel.

Each channel is divided into four columns: A, B, C, and D. These columns represent texture components you can use to set the value of the channel. At the top of each column is a Frequency slider. This slider lets you quickly set the frequency of a texture component. Setting the frequency is the same as scaling the texture.

When a texture component indicator appears in a column, it means that a component is

being used to drive the value of the channel. The column in which the indicator appears indicates which texture component is being used. For example, if a texture component indicator appears in column A of the Ambience channel, component A is being used to drive the Ambience value.



Component indicators let you know which channels are being driven by a texture and which texture component (A, B, C or D) is being used.

Texture Component Windows

Along the right side of the lab are the Texture Component windows. These four windows are also labeled A, B, C, and D. When a texture component is active, these windows display a preview of the texture and provide access to texture editing tools.

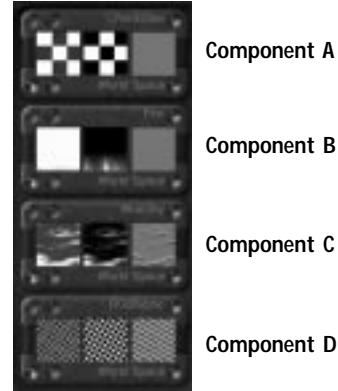

The four Texture Component windows correspond to the four columns in each channel in the Materials Grid

Along the bottom of the Materials Lab are the Animation controls. These controls let you

animate between textures or animate the properties of a single texture over time.



Use the Animation controls to animate a material over time.

Working in the Materials Lab

This section describes how to use the Materials Lab to create and store materials.

Building Materials

A material is a combination of values, colors and textures applied through fourteen different channels. You build materials by selecting components (colors, values or textures) and combining them on the Materials Grid.

To create a new surface material:

- 1 Select an object.
- 2 Display the Materials Lab.
- 3 Set the material channels to define the properties of your material.

Remember, channels can be set using values, colors or texture components. You may want to experiment with different settings to see the results of your changes.

- 4 If you're using texture components, you can:
 - Edit the scale, position or rotation of the texture using the texture transformation controls.

- Edit the makeup of the texture using the Deep Texture Editor.
- Set a mapping mode for the texture.

- 5 Choose a shading mode for the material by clicking the triangle icon at the top of the Materials Lab and choosing a mode from the menu.
- 6 Click the OK icon. The new material is applied to the selected object.

To create a new volume material:

- 1 Select an object.
- 2 Display the Material Lab.
- 3 Click the toggle button to switch to Volume.
- 4 Set the material channels to define the properties of your material.

Remember, channel values are applied to the object's volume not its surface, so adjust the material's channels accordingly.

- 5 If you're using texture components, you can:
 - Edit the scale, position or rotation of the texture using the texture transformation controls.
 - Edit the makeup of the texture using the Deep Texture Editor.
 - Set a mapping mode for the texture.

You should always use a texture component in the Base Density channel.

- 6 Choose a shading mode for the material by clicking the triangle icon at the top of the

Materials Lab and choosing a mode from the menu.

The shading modes for volume materials are different from those for surface materials.

- 7 Click the OK icon. The new material is applied to the selected object.

To activate a component in the Materials Grid:

- Click an empty channel column. A component window appears.

To use a component in a channel:

- In a material channel, click the column that corresponds to the component you want to use.

To switch between components:

- Click in a new column.

To combine a component with a value:

- 1 In a material channel, click an empty column.
- 2 Drag over the value control for the channel.

Copying and Pasting Materials

The Materials Lab has its own dedicated clipboard that lets you store materials. You can have an object in your clipboard, then enter the Materials Lab and copy a material without disturbing the contents of your clipboard.

To copy a material to the Materials clipboard:

- Click the Copy button below the Material Preview window.

To paste a material to the Materials clipboard:

- Click the Paste button below the Material Preview window.

Using the Material Preview Area

There are several different ways you can see the effects of your material on an object.

To switch preview modes:

- Click the triangle at the bottom of the material preview and choose an option from the menu:

Normal displays your object as it looks in your scene. This is the default view of your selected object.

Up Close displays a zoomed in view of your object.

Render With Neutral Sky displays your object against a plain sky. When disabled, your preview contains the current sky settings. This option makes it easier to see the material without being distracted by patterns in the sky.

Render With Neutral Ground displays your object with a plain ground. When disabled, the ground in your preview has the same texture as the object.

Current Selection displays the selected object exactly as it appears in the your scene.

Box displays the material applied to a cube.

Sphere displays the material applied to a sphere.

Cone displays the material applied to a cone.

Cylinder displays the material applied to a cylinder.

Terrain displays the material applied to a randomly generated terrain object.

Ground displays the material applied to an infinite plane.

Torus displays the material applied to a torus object. Torus objects are good for displaying material properties like altitude changes, slope and height changes, and metallicity.

To change the view angle of the preview area:

- Drag the Preview area in the direction you want to view it from.

The preview switches to wireframe as you move it. The angle of the preview does not affect the angle of the object in your scene.

Material Presets

Material presets are predefined materials. Presets contain channel values that simulate a wide variety of commonly used surfaces. Presets are stored in the Material Presets Library.

Presets are a great way of understanding how materials are made. You can open one of the presets and see what channel and components were used to create the final material.

The Material Presets Library can also be used as a cookbook. Some of the shaders are organized as lessons that can lead you through the process of creating interesting effects. For example, try opening the Specularity lessons in the Simple & Fast category.

Using the Preset Materials Library

The Preset Materials Library contains all the material presets available in Bryce. You can place them on your objects directly and edit them just as you would any other material.

To add a material from the Preset Materials Library to an object:

- 1 Select an object.
- 2 In the Working window, click the triangle icon next to the Edit text button at the top of the Bryce environment. The Preset Materials Library appears.

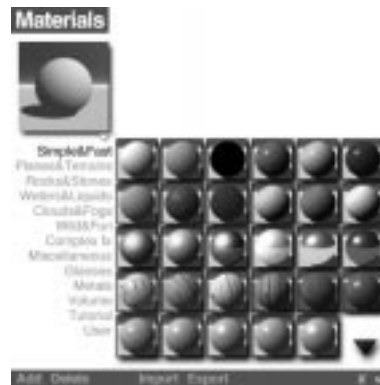

Use the Preset Materials Library to add pre-made materials to your object.

or

In the Materials Composer, click the triangle icon next to the Material Preview window

- 3 Click one of the Category names along the left side of the dialog.
- 4 Click the thumbnail of the preset you want to add.
- 5 Click the OK icon to add the selected material to your object.

You can also select presets in one motion by dragging directly to the desired material preset and releasing the mouse button. You can also drag over the category names to change categories into the category's presets, and then release mouse button.

Adding and Deleting Preset Materials

You can add the material from any object to the Preset Materials Library. This is a good way of saving your favorite materials.

To add a material to the library:

- 1 Select the object whose material you want to add to the library.
- 2 Click the triangle icon next to the Edit text button at the top of the Bryce environment. Your selected object will appear in the preview area of the Preset Material Library dialog.



The preview area displays the object you selected.

- 3 Click a category name. The library switches to the category you selected.

The new preset will be added to the category you select.

- 4 Click the triangle icon at the bottom right corner of the preview and choose a view option from the menu.

Normal is the default view of your selected object.

Up Close displays a close-up of your object.

Render With Neutral Sky displays your object with a flat sky instead of the sky applied to your scene.

Render With Neutral Ground displays your object on a flat ground plane instead of the ground used in your scene.

Current Selection displays your object exactly as it appears in your scene.

Box displays your material applied to a cube.

Sphere displays your material applied to a sphere.

Cone displays your material applied to a cone.

Cylinder displays your material applied to a cylinder.

Terrain displays your material applied to a terrain. You might want to disable Render With Neutral Ground as terrain materials look better when placed on a ground plane with the same material.

Ground displays your material applied to an infinite plane.

Torus displays your material applied to a torus object.

- 5 Drag the preview area to rotate the view of your object.

- 6 Hold down the Spacebar and drag up, down, right, or left to pan the your object preview.
- 7 Hold down Command/Ctrl and drag in the preview area to zoom in and out of the preview.
- 8 Click the Add button at the bottom of the dialog. The Add Material dialog appears.
- 9 Enter a name for the new preset in the Preset Name field.
- 10 Enter a description of the preset in the Description field and click the OK icon.
The name and description will appear next to the material preview whenever the preset is accessed.

You can edit the name and description of any preset at any time simply by pressing the Tab key or by clicking the name or description.

- 11 Click the OK icon. Your preset will be added to the first available space within the current category.

To delete a material preset:

- 1 Click the triangle icon next to the Edit text button at the top of the Bryce environment. The Preset Materials Library appears.
- 2 Click the preset you want to delete.
or
Hold down Shift and select a continuous series of presets.
or
Hold down Command/Ctrl and select a discontinuous set of presets.
- 3 Click the Delete button at the bottom of the Preset Materials Library dialog.

Importing and Exporting Preset Materials

Importing and exporting presets is a handy way to exchange custom presets with other users.

To import a preset material file:

- 1 Click the triangle icon next to the Edit text button at the top of the Bryce environment. The Preset Materials Library appears.
or
In the Materials Lab, click the triangle icon next to the Material Preview window.
- 2 Click the Import button at the bottom of the Preset Materials Library dialog. The File Open dialog appears.
- 3 Locate the file you want to import and click Import.
The contents of the file are placed into the first available space in the current category.

To export a preset material file:

- 1 Click the triangle icon next to the Edit text button at the top of the Bryce environment. The Preset Materials Library appears.
- 2 Select the preset or presets you want to export.
- 3 Click the Export button at the bottom of the Preset Materials Library dialog. The Save File dialog appears.
- 4 Enter a name and location for the file and click Save.

Animating Materials

Animating materials can add an exciting new dimension to your materials—time. Using the Animation controls, you can interpolate between textures over time or change the properties of a single texture over the course of an animation.

The animation tools are a great way of adding life to your scene. Instead of creating an animation with simple motion, you can create subtle effects like changing a cube from water to ice or changing the seasons on a mountain.

Refer to “Animating Materials” on page 388 for complete instructions on animating materials.

Speeding Up Materials

While there is almost an infinite number of materials with the added complexity of creating materials using multiple components and adding volumes, you need not use all the features of the lab all at once.

The more complex your material, the longer it takes to render so you should use complexity only where its necessary.

Rendering Transparency, Reflection and Refraction always require longer rendering time, but when you add the complexity of creating transparent, reflective or refractive volumes, your rendering time can increase exponentially. If you find that your scene is taking too long to render, you may want to try setting the Transparency, Reflection and Refraction values to zero.

Additionally, use Full Shading Volume textures sparingly. This type of material creates specific types of effects, so you should limit these materials to specific areas of your scene. If you

spread Full Shading Volume textures everywhere throughout your scene, be prepared for a long wait while the scene renders.



10

Textures

Textures and Materials

The thing that makes Bryce so unique is its materials. A material can truly bring any object to life, and textures are the power behind the material. A material can make your object shiny, dull, or transparent, but the textures within that material are what make it look like wood, rock, water or clouds.

Textures define the color, pattern or bumps within a material. A material can contain up to four textures. These textures can be used to drive the channels that make up the material. So, by altering the make-up or pattern of a texture you can dramatically alter the appearance of a material.

Texture Structure

A Bryce texture can be made up of three components. These components contribute the raw patterns or textures within a texture. Each component can then contribute one of three types of output to the final texture. These outputs are then combined to create the final texture.

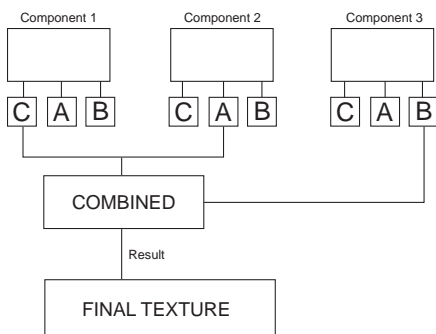

This diagram shows the structure of a texture.

Within each component is a combination of colors and noise that create a pattern. Noise is what creates the pattern within the texture. The shape of the noise inside a component is determined by the phase of the noise and the filter applied to it. The filter can create coherent patterns, random spots or anything in between. Refer to “Noise” on page 248, “Phase” on page 255 and “Filtering” on page 261 for more on Noise, Phase and Filtering.

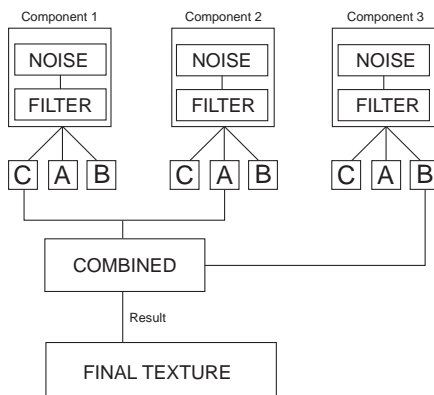

This diagram shows the structure of a texture including the structure of a component.

A component can contribute one of three types of output to the final texture: Color output, which determine the colors in a texture, Alpha output, which determines the bright and dark areas in a texture, and Bump output, which determines the size and pattern of bumps in the texture.

The component can contribute any combination of outputs. So you can have a final texture that contains Color output, Alpha output, and Bump output, or it can have all Color output or all Bump, or any combination of the three.

The outputs in a texture are used by the material, so the type of output you have in a texture depends entirely on how you want to use the texture in the material. For example, if you’re using the texture as a bump map for the Bump Height channel in a material, you’d probably want all the components to contribute only Bump output.

A texture can contain up to three components. It can be made up of all three components or just one, depending on the type of texture you want to create. The more components you use, the more complex your texture.

Components are combined using Blend Modes. These modes can create a wide range of effects.

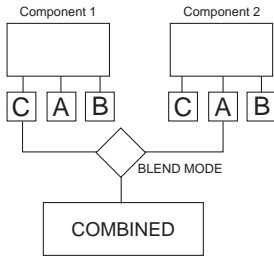

The way components are combined to create the final texture is determined by the Blend Mode you select.

Components are combined differently depending on how many you use. If you use one or two they are combined according to the blend method you select. If you use three, the first two components are combined, and the resulting texture is then combined with the third component to create the final texture.

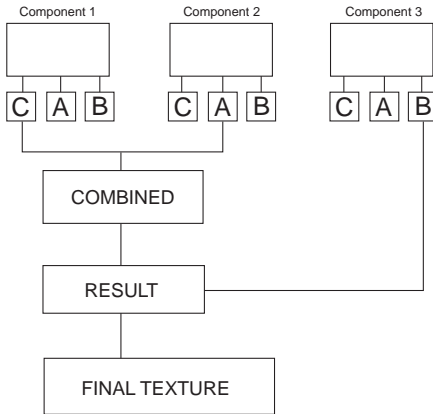

When you use three components, the first two components (C1 and C2) combine to create a hybrid texture which is then combined with the third component (C3) to create the final texture. So they're combined using the formula $(C1+C2)+C3=FINAL$.

The texture components are combined together to form the final Combination texture. The final texture can have its own color scheme, noise, phase or filter. Any changes you make to the

combination texture changes the final texture. These types of operations are called Global changes. Refer to “Global Changes” on page 270 for more on global changes.



Changes to this texture are global

When the components are combined they produce the combination texture. This texture can have its own color scheme, noise, phase or filter. These operations are called Global changes.

The end result of the Global changes is the final texture which can then be used in the Materials lab to create a material.

Components vs. Texture Components

Before you get any deeper into the discussion of texture structure you should understand a little terminology.

A texture is a part of a material. It can be used to drive any of the material's channels. When you use a texture in a materials it's called a *material component*.

The texture itself also has components. It can be made up of up to three components that determine the look and color of the texture.

The components that make up a texture are called *components*.

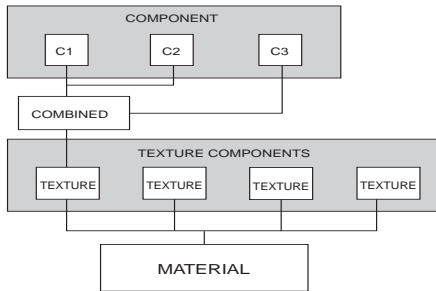

The difference between components and texture components may be a bit confusing. Just remember that when you're talking about a texture, you're dealing with components. When you're working with materials, you're using texture components.

Understanding Component Structure

A texture can have up to three components. When combined, the components create the final texture. A component consists of noise and color.

A component can have up to three colors. The combined texture can also have a different set of three colors which is added to the colors from the components. In total your texture can contain up to twelve colors.

The noise in a component is made of base Noise which is modified by the Phase, which controls the complexity of the noise, and the

Filter, which determines the shape or pattern of the noise.

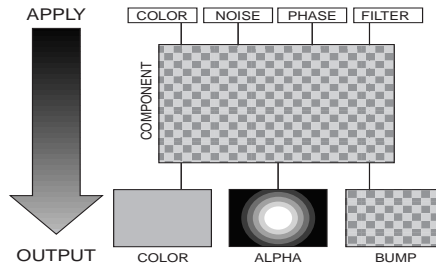

A component consists of noise and color. The Noise is modified by the Phase and the Filter. Each component can then produce Color, Alpha or Bump output.

Components and Output

A component's output type determines what type of information it's going to contribute to the final texture. The Output type also determines the component's structure. A component that does not have a Color output won't contain any color information. The same is true for the two other types of output. If there's no Alpha or Bump output there's no Alpha or Bump information in the component.

Component Output

The main purpose of creating a component is to use it as part of a material which will then be applied to an object. How and what a texture contributes to a material is determined by the type of output it produces.

A texture can produce three different types of output: Color, Alpha and Bump.

When you apply a texture to a material, you can see the output types in the Texture Component Window in the Materials Lab.

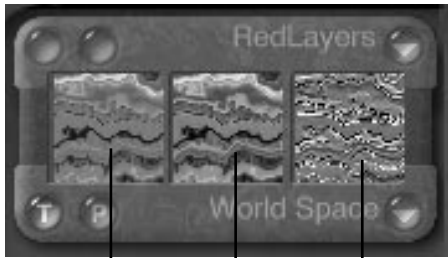

Color output Alpha output Bump output

The three boxes in the Texture Component Window in the Materials Lab represent the three output types available for a texture.

If a texture does not produce a particular output the box appears gray.

Refer to “Texture Components” on page 209 for more on using textures in materials.

In the Deep Texture Editor, the output type for a component is indicated by the three output buttons along the left side of the Component Window.

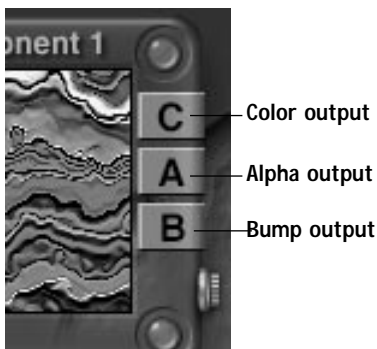

The three buttons along the right side of the Component window indicate the output type for a component. If a button appears depressed, it means that the component produces the selected output type.

Assigning Output Types

A texture can produce all three output types or only one. The number of output types for the final texture depends on the output you assign to the components. A component can produce one or all three types of outputs.

You can assign more than one component to the same output type. If you do have more than one component with the same output type, the output information will be blended to produce a final output.

For example, if you have two components that produce Color output, when you combine them the colors from both components are blended together and the result is applied to the final texture.

In order to produce an output type, a final texture must contain at least one component that produces the type of output you want. For example, if you want your final texture to contain color output, at least one of its components must produce color output.

Each output type contributes something different to the final material.

Color Output

Color output is used by the color channels of a material. The color values you assign to a texture’s components are combined to form a final texture. The combined values are then used to drive the Diffuse, Ambient, Specularity, Specular Halo, or Transparency color channels. Refer to “Understanding Surface Material Channels” on page 190 for more on these channels.

The colors in a texture usually appear in the form of a pattern or grain. When you assign the

texture to a material, this pattern appears in the final material.



Original Texture



Material containing texture

The texture in this example was applied to the Diffuse color and Ambient Color channels of the object's material. You can see how the color pattern in the texture appears in the material.

To assign Color output to a texture:

- 1 Display the Deep Texture Editor.
- 2 In the desired component window, click the C button on the right side of the component window.

Alpha Output

Alpha output is used by the various Intensity and Optic channels of the material. When a texture's Alpha output is assigned to a material, it's used to either to determine an effect's intensity or as a guide map for combining multiple textures.

When there is only one texture component in a material channel, the texture's Alpha output is usually used to determine the intensity of a channel effect. For example, if you assign a texture to the Diffuse channel, the texture's Alpha output is used to determine which areas

are the most diffuse and which are the least diffuse.

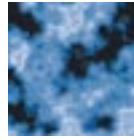

Original Texture



Material containing texture

The texture in this example was applied to the Diffuse channel of the object's material. You can see how the alpha pattern in the texture controls the diffuse intensity on the object's surface.

To assign Alpha output to a texture:

- 1 Display the Deep Texture Editor.
- 2 In the desired component window, click the A button on the right side of the component window.

Bump Output

The Bump output is used only by the Bump Height material channel to determine the pattern and height of the bumps in a material.



Original Texture



Material containing texture

The texture in this example was applied to the Bump Height channel of the object's material. You can see how the bump output in the texture controls the pattern of bumps on the object's surface.

To assign Bump output to a texture:

- 1 Display the Deep Texture Editor.
- 2 In the desired component window, click the B button on the right side of the component window.

Component Elements

A texture is made up of components. Each of those components can contain several elements that determine the color, pattern, grain or bumps in the component.

The Component window

You can have up to three components in your texture. As you activate components, a component window becomes active. Each window displays a preview of the component elements.

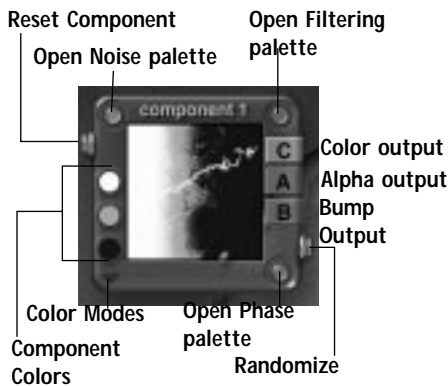

The Component window displays the selected component and its current attributes.

The three buttons on the Component window let you access the Noise palette, the Filtering palette and the Phase palette. The buttons along the right side of the window indicate the type of output produced by the component.

To activate a component:

- 1 Display the Deep Texture Editor.
- 2 Click the component selector in the top-left corner of the editor.



The component selector lets you pick how many components you want to use to build your texture.

The selector lets you choose from 1, 2, or 3 components.

Color

The colors in a component determine its color scheme. Each component can have up to three colors. Colors can be chosen using the color picker or the Color dialog.

The color in a component is affected by the noise, phase and filter. You can create some very interesting patterns of color by modifying the noise. The color pattern created by the changes in the noise is applied directly to the final texture. So even if Color is the only output type for the component you'll still see a pattern in your final texture.

When the Color Output is selected for a component, only the color information is combined with the other components. Also, when you apply the texture to a material, the colors in the component contribute to the colors used in the Color channels of the material.

There are two color models you can use to create colors in the components: RGB and HLS. RGB combines red, green and blue to create color. HLS combines Hue, Lightness and Saturation values to create color. The method you choose depends on the final output of your Bryce scene. RGB usually works best for most types of output.

If the Color output is not active for a component, changing the colors or Color Blending Modes has no effect.

To activate Color output for a component:

- 1 Display the Deep Texture Editor.
- 2 In the desired component window, click the C button.



The three buttons along the right side of the component window display the component's output type.

An output type is active when the button appears light gray.

To choose colors for a component:

- 1 Display the Deep Texture Editor.
- 2 In the desired component window, make sure the C button is selected.

- 3 Click one of the color indicators along the left side of the component window and choose a color from the palette.



The three color indicators along the left side of the window display the colors used in the component.

To mix colors for a component:

- 1 Display the Deep Texture Editor.
- 2 In the desired component window, make sure the C button is selected.
- 3 Option/Alt-click the one of the color indicators along the left side of the component window. The Color dialog appears.



The Color dialog lets you mix a color to use in the component by entering values or adjusting the color sliders.

- 4 Choose a color model by clicking one of the buttons along the bottom of the dialog.
- 5 Enter color values or adjust the sliders to mix a new color.
- 6 Click the OK icon.

Color Blending Modes

There are several blending modes you can use to create a color scheme.

To choose a Color Blending mode:

- 1 Display the Deep Texture Editor.
- 2 In the desired component window, make sure the C button is active.
- 3 Click the triangle icon in the lower left corner of the window and choose a mode from the menu.



The pop-up lists all the Color Blending Modes available in the Deep Texture Editor.

None

No blending is applied.

Red or Hue

When the RGB model is used, this mode outputs only red color values. When the HLS model is used, only Hue values are output.

This mode and the Green or Light, and Blue or Saturation mode are available so that you can separate color values among the components. For example, you could set each component to output one of the different color values.

Green or Light

When the RGB model is used, this mode outputs only green color values. When the HLS model is used, only Lightness values are output.

Blue or Saturation

When the RGB model is used, this mode outputs only blue color values. When the HLS model is used, only Saturation values are output.

Spline Interpol

This mode creates a blend between all the colors in the component.

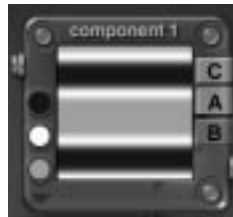

This is what a color blend looks like using Spline Interpol.

Linear Interpol 2

This mode creates a linear blend between the first two colors selected for the component.

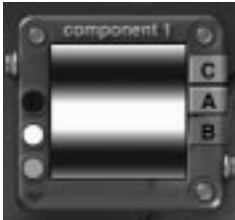

This is what a color blend looks like using Linear Interpol 2.

Linear Interpol 3

This mode creates a linear blend between all the colors in the component.



This is what a color blend looks like using Linear Interpol 3.

Randomized

In this mode the three colors are blended and then applied randomly throughout the component.

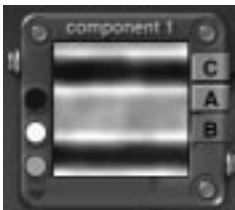

This is what a color blend looks like using Randomized.

Earth Map

In this mode extra colors are generated according to the contours of the component's bump map. The three colors you selected for the component are applied to the middle range of the bump map. Blue is applied to the lowest bump values and white is applied to the highest values to simulate polar caps. Earth Map is excellent for creating planets.

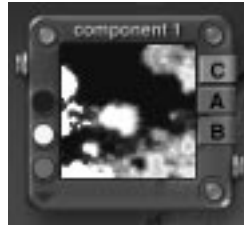

This is what a color blend looks like using Earth Map.

Banded

In this mode colors are applied in bands. The bands are determined by color values. Colors with the lowest value (i.e. dark colors) are applied to the bands furthest from the center, colors with middle range values are applied next and colors with the highest values (i.e. bright colors) are applied closest to the center.

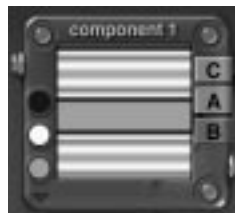

This is what a color blend looks like using Banded.

Perturbed

In this mode colors are applied in irregular patterns.

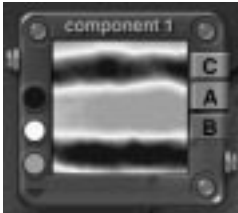

This is what a color blend looks like using Perturbed.

Interferences

In this mode the red, green and blue values of the first color in the component are used to create a repeating pattern around the contours of the component's noise.



This is what a color blend looks like using Interferences.

Interpol + Interferences

This mode is a combination of Linear Interpolation and Interferences.



This is what a color blend looks like using Interpol + Interferences.

Altitude

In this mode a white layer is added above the colors at high altitudes. Any portion of the object below ground is automatically colored blue. Altitudes are based on the object's height.

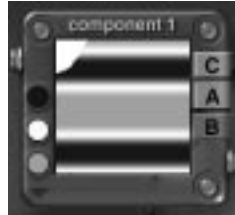

This is what a color blend looks like using Altitude.

Spline with Snow

This mode performs a spline interpolation of the colors in the component, but adds a white layer above the colors at high altitudes. Altitudes are based on the object's height.

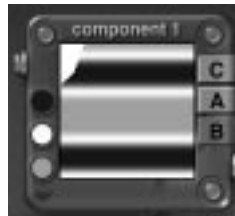

This is what a color blend looks like using Spline with Snow.

Slope

In this mode the three colors are applied to the object depending on its slope.



This is what a color blend looks like using Slope.

Orient

In this mode the three colors are applied to the object according to its east-west orientation.

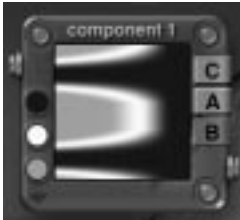

This is what a color blend looks like using Orient.

Noise

Noise is the basis of all the textures. It is the background turbulence that creates the basis for texture patterns.

In audio terms you can think of noise as the background static that you hear on old recordings. Sound is layered on top of this noise to create music. Like in audio, you layer other functions on top of the noise in your texture to create the final pattern or look of your texture.

There are two ways of creating noise: the Noise palette or the Noise Editor.

The Noise palette can increase or decrease the amount of noise in any of the texture components. However, using the palette, you can only edit the existing noise.

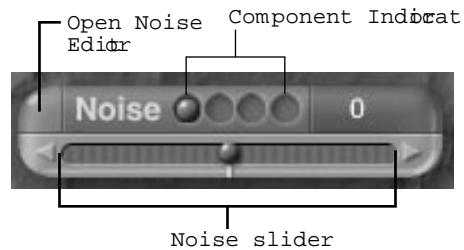

The Noise palette lets you increase or decrease the amount of noise in a component.

To display the Noise palette:

- 1 Display the Deep Texture Editor.
- 2 Click the Noise button at the bottom of the editor. The Noise palette appears.



The three buttons at the bottom of the Deep Texture Editor let you display the Noise, Phase and Filter palettes.

or

- Click the Noise button in the top-left corner of on any of the component windows.



The three buttons along the outside of a component window let you display the Noise, Phase and Filter palettes.

The Noise Editor is much more powerful than the Noise palette. It contains controls for creating noise from scratch.

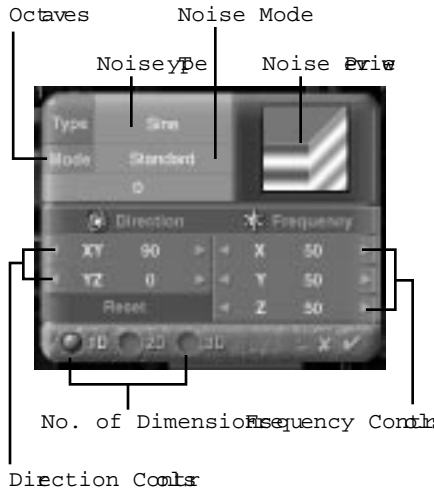

The Noise Editor lets you create noise and adjust its properties.

To display the Noise Editor:

- 1 Display the Deep Texture Editor.
- 2 Click the Noise button at the bottom of the editor. The Noise palette appears.
- 3 Click the top-left corner of the palette. The corner turns green as you pass your cursor over it.

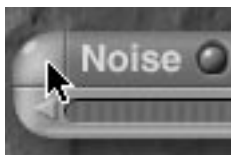

The top-left corner of the Noise palette lets you display the Noise Editor.

Creating Noise

The Noise editor is the tool you'll use to create noise with a component or combined texture. The noise creation process involves several steps:

- Choose the number of dimensions in the noise.
- Choose a Noise Type. This will give the basis for creating a noise pattern or grain.
- Adjust the frequency of the noise.
- Adjust the orientation of the noise.
- Apply a modifier to your noise, by choosing a Noise Mode.

The following sections describe the various parts of the editor and how to use them in the noise creation process.

Noise Dimensions

Texture in Bryce can exist in 3D so your noise can have up to three dimensions. Noise dimensions determine which axes you can use to adjust the orientation and frequency of the noise.

It's easier to see the number of dimensions for your noise if you use a cube in the Noise Preview.



1D Noise 2D Noise 3D Noise

These three examples show the difference between 1D, 2D and 3D noise.

To choose the number of dimensions for your noise:

- 1 Display the Deep Texture Editor.
- 2 Display the Noise Editor.
- 3 Click one of the dimension buttons at the bottom of the editor.



The three buttons at the bottom of the editor let you choose between 1D, 2D and 3D noise.

Noise Type

There are 27 different types of noise available in the Noise Editor. Random noise is the default (RND).

Each noise type provides you with a different basic pattern to start your texture. Some are more linear or geometrical while others are more random.

More complex noise types require more rendering time. The time it takes to render the preview is a good indication of how long the final texture will take to render.

You should use the more complex noise types cautiously.

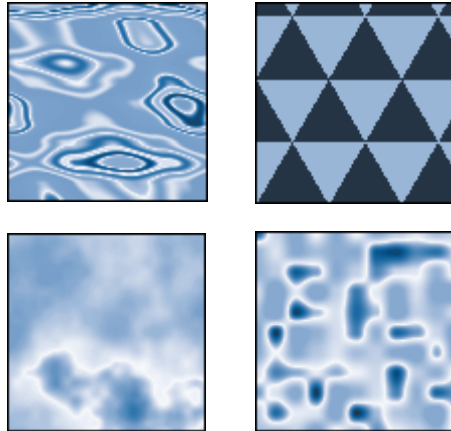

These are examples of some of the types of noise available.

The best way of choosing a noise type is to apply a few to your component and see how they look. Remember that this noise is only the basis of the texture. You can still edit this noise using the other controls in the editor, so don't discard a noise type because it's not perfect. The other controls can help you fine-tune the noise.

To choose a noise type:

- 1 Display the Deep Texture Editor.
- 2 Display the Noise Editor.
- 3 Click the type field at the top of the editor and choose a noise type from the menu.



The Type area at the top of the editor displays the name of the currently selected noise type.

Noise Frequency

Noise Frequency determines how often the pattern within a texture repeats. Frequency is like scaling the noise. Higher frequencies decrease the scale of the noise so you can see the pattern more often. Lower frequencies increase the scale of the noise so the pattern repeats less often.

You can change noise frequency using the Frequency fields. The fields let you enter numerical values to adjust the noise frequency along the X, Y or Z axis. You can also adjust the values using the scroll arrows.

The number of dimensions in the noise determines how many axes you can use to adjust the frequency. For 1D noise you can only use the X axis. With 2D noise you can use both the X and Y axes. For 3D noise you can use all the axes.

If you try to adjust the Z axis frequency for a 2D noise, your changes will have no effect.

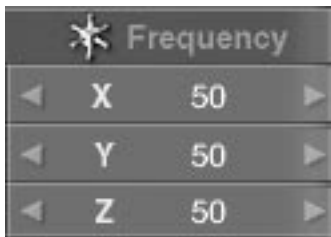

The Frequency fields let you enter values to precisely control the noise frequency along the X, Y or Z axes.

Adjusting the frequency can radically change the look of your noise. If you adjust the

frequency in separate axes, you can achieve even more interesting effects.

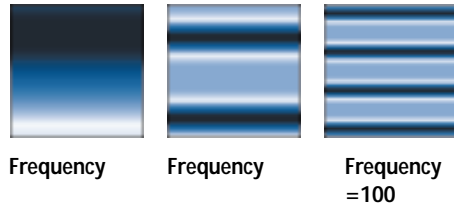

Noise frequency settings control the repetition of patterns in a component.



Frequency X=10 Y=80 Z= 10

In this example, the noise frequency was changed in only the Y axis.

To change the frequency of noise:

- 1 Display the Deep Texture Editor.
- 2 Display the Noise Editor.
- 3 Drag over the X field in the Frequency area to set the noise frequency in the X axis. Drag left to decrease the value or right to increase it.
- 4 Drag over the Y field in the Frequency area to set the noise frequency in the Y axis.
- 5 Drag over the Z field in the Frequency area to set the noise frequency in the Z axis.

You can also drag over the scroll arrows to speed up the increments.

Noise Orientation

Noise Orientation controls the direction of the noise. Noise has a grain or a fixed up and down, when you adjust the orientation you change how the noise is laid out within the texture.

When you apply a texture, the direction of the noise within the texture remains constant regardless of the orientation of the object.

Since noise can exist in three dimensions, you adjust the direction of the noise in the X, Y, or Z axis.

The number of dimensions in the noise determines how many axes you can use to adjust the orientation. For 1D noise you can only use the X axis. With 2D noise you can use both the X and Y axes. For 3D noise you can use all the axes.

You can edit the noise orientation using the Direction numerical fields. The fields let you enter precise angles for noise orientation. You can also use the scroll arrows to set the angle in increments.



The Direction fields let you enter rotation angles to precisely control the noise direction along the X, Y or Z axes.

Changing noise orientation can dramatically change the look of your noise. You'll see just

how different your noise can look when you rotate it along a single axis.



Rotation in Rotation in Rotation in XYZ

Noise orientation controls the direction of the noise.

To change the orientation of noise:

- 1 Display the Deep Texture Editor.
- 2 Display the Noise Editor.
- 3 Drag over the XY field in the Direction area to set the noise angle in the X and Y axes.
Drag left to decrease the value or right to increase it.
- 4 Drag over the YZ field in the Direction area to set the noise angle in the Y and Z axes.

You can also drag over the scroll arrows to speed up the increments.

Noise Octaves

Noise octaves are like musical octaves. In a musical scale, if you play F and then F an octave down, you're playing the same note, only it sounds lower. If you play both notes at the same time, the sound is more complex than if you played only one note. The same is true of noise. When you add an octave to noise it

becomes more complex but the type of noise remains the same.



1 Octave 2 Octaves 3 Octaves

These examples use RND Continuous noise and RND Linear noise to show the effects of increasing octaves.

Increasing the octaves adds processing time to the component.

To change the number of octaves:

- 1 Display the Deep Texture Editor.
- 2 Display the Noise Editor.
- 3 Drag over the octaves field at the top of the editor.



The octaves field at the top of the editor displays the number of octaves currently applied to the noise.

Noise Modes

Noise modes modify the octaves of a noise. As you add complexity by increasing the octaves, the Noise Modes let you modify the additional noise so that it produces different effects.

Many of the Noise modes use dark and light values to modify the existing noise. Also, you may not see the effects of the modes if the Octave is set to 0.

To choose a Noise Mode:

- 1 Display the Deep Texture Editor.
- 2 Display the Noise Editor.
- 3 Click the Mode field at the top of the editor and choose a mode from the menu.

There are thirteen noise modes available:

Standard

This mode adds a new octave to the noise at half the frequency and twice the amplitude. This is the default mode.



In this example, Standard mode was applied to RND Continuous noise.

Irregular

This mode adds a new octave to the noise at half the frequency and twice the amplitude. However, in this mode higher frequency noise is modified more than the rest. The end result is that more detail is added to the noise.



In this example, Irregular mode was applied to RND Continuous noise.

More Irregular

This mode works exactly like Irregular except that this mode is more intense.



In this example, More Irregular mode was applied to RND Continuous noise.

Maximum

This mode uses only the highest values, or lightest areas, to produce the modified noise.



In this example, Maximum mode was applied to RND Continuous noise.

Multifractal

In this mode lighter areas create higher contrast noise.



In this example, Multifractal mode was applied to RND Continuous noise.

With Rotation

In this mode each additional octave is rotated. With Rotation mode it's easier to see linear noise types.

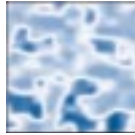

In this example, With Rotation mode was applied to RND Linear noise.

Minimum

This mode uses only the lowest values, or darkest areas, to produce the modified noise.

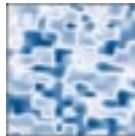

In this example, Minimum mode was applied to RND Continuous noise.

Multiply

In this mode all the values in the noise are multiplied together. The results is a darker noise.

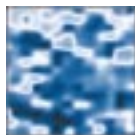

In this example, Multiply mode was applied to RND Continuous noise.

Difference

In this mode all the values in the noise are evaluated. All the values that are equal create black areas. When the values are different, the lower value becomes darker. The more octaves you have in the noise, the darker the modified noise. Difference works even at 0 octaves.

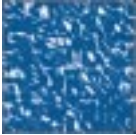

In this example, Difference mode was applied to RND Continuous noise.

Minimum 90

This mode repeats the noise at a 90° angle from its original orientation and combines the original and copy using only the highest values. This mode is good for creating woven patterns.

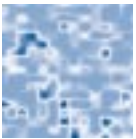

In this example, Minimum 90 mode was applied to RND Continuous noise.

Maximum 90

This mode repeats the noise at a 90° angle from its original orientation and combines the original and copy using only the lowest values.

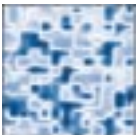

In this example, Maximum mode was applied to RND Continuous noise.

Auto-phased

This mode automatically introduces phase shifts into the noise.



In this example, Auto-phased mode was applied to RND Continuous noise.

Displaced Max

This mode creates a copy of the noise and displaces noise by a small amount and then lightens any areas where the two overlap. This mode is good for creating stone textures.



In this example, Displaced Max mode was applied to RND Continuous noise.

Phase

Phase introduces turbulence into your noise. The phase displaces the grain or patterns within the your noise. When you design the phase, you're creating a displacement map along which the noise will be modified.

You can control how the phase interacts with your noise using the Phase palette. You can design your phase using the Phase Editor.

The Phase palette controls the amplitude. The phase amplitude controls the intensity of the displacement. As the amplitude is increased, there is more interference with the original noise.

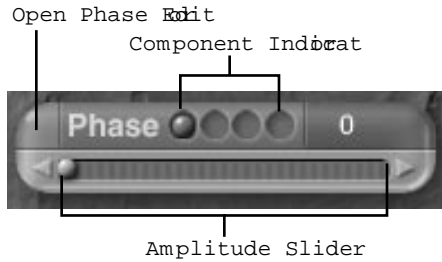

The Phase palette lets you increase or decrease the amplitude of the phase in a component.

You won't have to increase the amplitude very much before you start seeing the phase pattern you designed interfere with the existing noise. In fact, it's probably a good idea to keep the phase amplitude low so that the phase pattern doesn't overwhelm the noise.

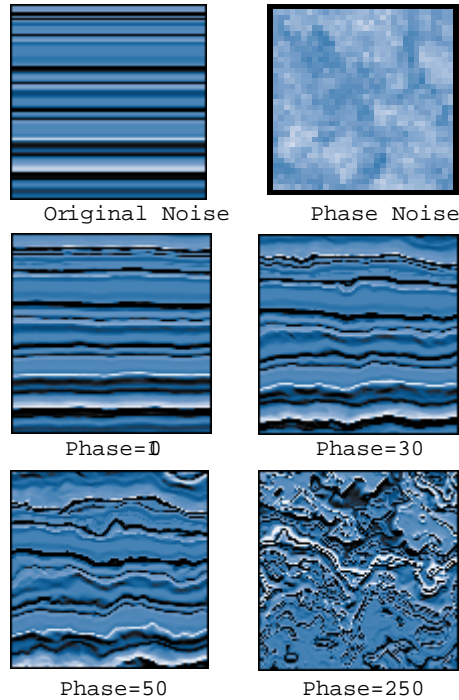

This graph shows how the phase interacts with the noise at different amplitude settings.

To display the Phase palette:

- 1 Display the Deep Texture Editor.
- 2 Click the Phase button at the bottom of the editor. The Phase palette appears.



The three buttons at the bottom of the Deep Texture Editor let you display the Noise, Phase and Filter palettes.

or

- Click the Phase button in the bottom-right corner of any of the component windows.



The three buttons along the outside of a component window let you display the Noise, Phase and Filter palettes.

The Phase Editor looks a lot like the Noise Editor. It has the same type of tools and they work exactly like they do in the Noise Editor. The difference is that you're using noise patterns, orientations, frequencies and modes to design how the basic Noise will be displaced.

Using the Phase Editor you can perform several functions:

- Create 1D, 2D, or 3D phase.
- Change the type of noise.
- Change the frequency of the phase.
- Change the orientation of the phase.
- Change the noise octaves.
- Change the noise modulations.

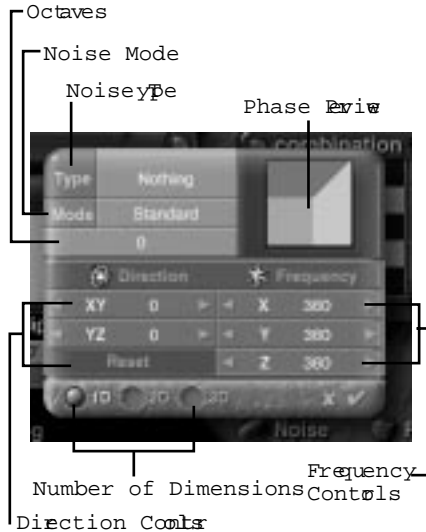

The Phase Editor lets you create noise to use as phase.

While the Phase Editor lets you create the noise pattern or grain within the phase, the Phase palette controls how that phase is applied to the component or the combined texture.

To display the Phase Editor:

- 1 Display the Deep Texture Editor.
- 2 Click the Phase button at the bottom of the editor. The Phase palette appears.
- 3 Click the top left corner of the palette. The corner turns green as you pass your cursor over it.



The top left corner of the Phase palette lets you display the Phase Editor.

Creating Phase

Phase is designed using the Phase Editor. The phase creation process involves several steps:

- Choose the number of dimensions in the phase.
- Choose a noise type. This gives the basis for creating a phase pattern or grain.
- Adjust the frequency of the noise.
- Adjust the orientation of the noise.
- Apply a modifier to the noise by choosing a Noise Mode.

You'll notice that many of the steps for creating the phase are the same as those for creating noise. That's because you *are* creating noise. The difference is that instead of applying the noise to the texture, the noise you create for the phase is used to displace the existing noise.

The following sections describe the various parts of the editor and how to use them in the noise creation process.

Phase Dimensions

Just like noise, you can set the dimensions of the phase. The number of dimensions determines which noise axes will be displaced when you apply the phase. For example, if you apply a one-dimensional phase to a three-dimensional noise, only the X axis of the noise will be displaced.

Its easier to see the number of dimensions for your phase if you use a cube in the Phase Preview.



Combined Texture



3D Noise

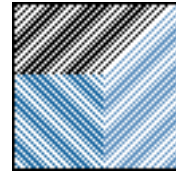

1D Phase

In this example, a 1D phase was applied to a 3D noise.

To choose the number of dimensions for your phase:

- 1 Display the Deep Texture Editor.
- 2 Display the Phase Editor.
- 3 Click one of the dimension buttons at the bottom of the editor.



The three buttons at the bottom of the editor let you choose between 1D, 2D and 3D phase.

Phase Noise Type

There are 27 types of noise available in the Phase Editor. Random Noise is the default (RND).

Each noise type provides you with a different basic pattern for the phase. The noise types available in the Phase Editor are the same as those in the Noise Editor, so you can refer to “Noise Type” on page 250 for more on noise types.

Phase Frequency

Phase frequency determines how often the pattern within the noise repeats. Frequency is like scaling the noise. Higher frequencies decrease the scale of the noise so you can see the pattern more often. Lower frequencies increase the scale of the noise so the pattern repeats less often.

You can change phase noise frequency using the Frequency numerical fields. The fields let you enter numerical values to adjust the noise frequency along the X, Y or Z axis. You can also adjust the values using the scroll arrows.

The number of dimensions in the phase determines how many axes you can use to adjust the noise frequency. For 1D phase you can only use the X axis. With 2D phase you can use both the X and Y axes. For 3D phase you can use all the axes.

Adjusting the frequency of the Phase noise disproportionately can have some very interesting effects on your noise.



Frequency X=10 Y=80 Z= 10

In this example, the phase noise frequency was changed in only the Y axis and then applied to 3D noise.

To change the frequency of phase noise:

- 1 Display the Deep Texture Editor.
- 2 Display the Phase Editor.
- 3 Drag over the X field in the Frequency area to set the phase noise frequency in the X axis.



The Frequency fields let you enter values to precisely control the noise frequency along the X, Y or Z axes.

Drag left to decrease the value or right to increase it.

- 4 Drag over the Y field in the Frequency area to set the Phase noise frequency in the Y axis.

- 5 Drag over the Z field in the Frequency area to set the Phase noise frequency in the Z axis.

You can also drag over the scroll arrows to speed up the increments.

Phase Noise Orientation

Phase noise orientation controls the direction of the noise within the phase.

The number of dimensions in the phase determines how many axes you can use to adjust the orientation.

You can edit the noise orientation using the Direction numerical fields. The fields let you enter precise angles for noise orientation. You can also use the scroll arrows to set the angle in increments.

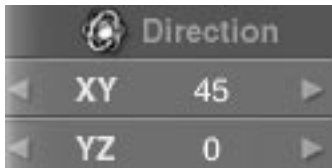

The Direction fields let you enter rotation angles to precisely control the noise direction along the X, Y or Z axes.

Like frequency, changing the orientation of the phase noise in only one or two axes can create some very interesting results.



In this example, the phase noise orientation was changed in only the Y axis and then applied to 3D noise.

To change the orientation of phase noise:

- 1 Display the Deep Texture Editor.
- 2 Display the Phase Editor.
- 3 Drag over the XY field in the Direction area to set the noise angle in the X and Y axes.
Drag left to decrease the value or right to increase it.
- 4 Drag over the YZ field in the Direction area to set the noise angle in the Y and Z axes.

You can also drag over the scroll arrows to speed up the increments.

Phase Noise Octaves

Phase noise octaves work exactly like the noise octaves. They introduce an extra level of complexity to the noise. Refer to “Noise Octaves” on page 252 for more on octaves.

Phase Noise Modes

Phase noise modes work exactly like the noise modes. They modify the octaves of a noise. They modify the octaves of a noise. They modify the octaves of a noise. Refer to “Noise Modes” on page 253 for more on octaves.

Filtering

The filter you apply to the noise in a component can change the entire look of the noise. The filter refines the noise so that it has more or less detail, increases its contrast, applies it only at high altitude or changes its spatial orientation. Whatever the change, the filter has a profound effect on the final look of your texture.

Filters are expressed as equations with variables. When the equation is applied to the noise, it changes some aspect of the noise. You can control how the equation affects the noise by changing the values of the variables.

The filter only affects the noise. The phase cannot be altered using a filter. The phase is blended with the noise.

Filters are edited using the Filtering palette. The palette displays the current filter and provides tools for editing the filter graph.

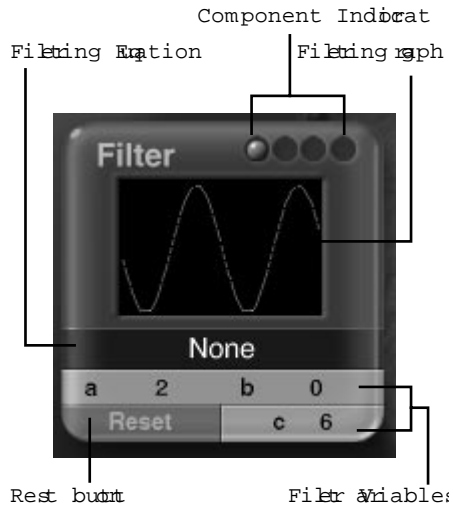

The Filtering palette displays the current filter and provides tools for editing it.

To display the Filtering palette:

- 1 Display the Deep Texture Editor.
- 2 Click the Filtering button at the bottom of the editor.



The three buttons at the bottom of the Deep Texture Editor let you display the Noise, Phase and Filter palettes.

or

- Click the Filtering button in the top-right corner of any of the component windows.



The three buttons along the outside of a component window let you display the Noise, Phase and Filter palettes.

Editing the Filter

Filters are equations which have variables. Each equation can have up to three variables labeled a , b and c . The values for each variable are displayed at the bottom of the palette. Generally, a controls the intensity of the filter effect while b controls the overall height. In some filters a and b may stand for other things.

There are two ways you can adjust a filter: by changing the variable values or by changing the shape of the graph (which automatically changes the variable values). The method you use depends on how much you know about a particular filter. If you're not sure what the filter does, change the graph—it's a much more intuitive way of working.

To edit the Filtering graph:

- 1 Display the Filtering palette.
- 2 Drag over the Filtering graph area. The shape of the graph changes as you drag.

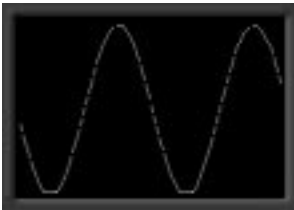

The graph area of the Filtering palette lets you interactively adjust the filtering effect.

Notice that the variables also changes as you move the graph.

- Dragging horizontally changes the value of a .
- Dragging vertically changes the value of b .

To change variable values:

- 1 Display the Filtering palette.
- 2 Drag over the variable field you want to change. Drag left to reduce the value or right to increase it.

The shape of the graph changes as you adjust the values.

Choosing a Filter

Each filter available in the Filtering palette offers something unique. The best way of choosing which filter you want to use is to apply it to a component and see what happens.

To choose a filter:

- 1 Display the Deep Texture Editor.
- 2 Display the Filtering palette.
- 3 Click the Filtering Equation area and choose a filter from the menu.

There are fourteen filters available. The following sections describe the filters and gives you some idea of how to edit them.

None

This option deactivates the filter. No filtering is applied to the component.

Quantize

This filter works like a Posterize effect. When its applied, gray values jump from one value to the next, creating a blocky stair-step type of effect.

In this filter a and b control the contrast and height, while c controls the number of levels between white and black.

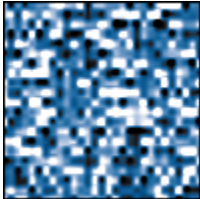

RND Continuous Noise

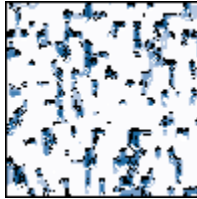

RND Continuous Noise + Quantization

In this example, Quantize was applied to RND Continuous noise.

Saw Wave

When the graph for this filter has only a small curve, it acts like a contrast filter. As it approaches the height limits (set by b), it bounces back on itself. This creates high-contrast breaks in the noise.

For color output use this filter to get areas of high-contrast alternating color.

When you set the value of a to a high number you'll get areas with a larger amount of noise.

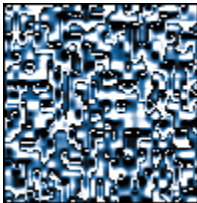

In this example, Saw Wave was applied to RND Continuous noise.

Sine Wave— $\sin(aX) + b$

This filter creates noise that appears as large number of lines that are oriented in the same

direction. Use this filter to generate wood grains.

The a variable controls the number of lines. Higher values create a better effect.

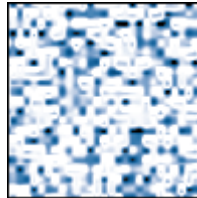

In this example, Sine Wave was applied to RND Continuous noise.

Absolute— $\text{Abs}(aX + b)$

This filter works like a Difference effect. When it's applied, you'll get more light areas in your noise and a higher level of detail in a bump map.

To get additional bump information using this filter, set a to 2 and b to -1.

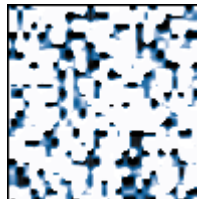

In this example, Absolute was applied to RND Continuous noise.

XPower—(X PWR a) + b

This filter smooths out the darkest areas of your noise. However it has less effect on lighter areas and no effect on white.

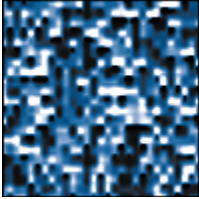

In this example, XPower was applied to RND Continuous noise.

Gaussian—(a(X + b))

This filter smooths out darker areas of your noise and makes lighter areas noisier. White areas become the noisiest.

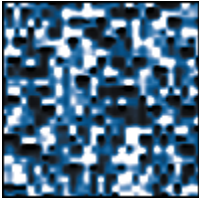

In this example, Gaussian was applied to RND Continuous noise.

Clip aX + b

Clip is probably the filter you'll use most. It's a contrast filter.

The a variable controls the contrast and b controls the overall brightness.

For a low contrast effect make the wave in the graph smaller. Decrease the value of a to reduce the size of the wave and increase b to move the wave up. Using this wave, all the values will be expressed as mid-gray.

For a high contrast effect, adjust the wave so that it hits both the top and bottom edges of the preview. Increase the value of a and make b negative to move the curve down.

To invert the colors in your noise, make a negative and increase b .

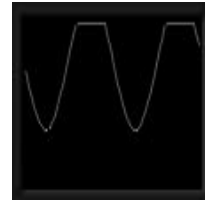
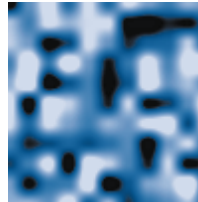

In this example, different levels of Clip were applied to RND Continuous noise.

Altitude Minus Slope—Xb + a (Altitude-Slope)

This filter applies noise only at certain combinations of slope and altitude. When a is positive and b is negative, noise is applied at high altitudes and on flat surfaces.

When a is negative and b is positive, noise is applied at low altitudes and on steep slopes.

The Altitude Minus Slope filter works on the slope and altitude of an object in World Space.



In this example, Altitude Minus Slope was applied to RND Continuous noise and then to objects in a scene.

Slope— $X(a * \text{Slope} + b)$

This filter applies noise based on an object's slope. Slope can range anywhere from flat and horizontal to steep and vertical. This is an excellent filter to use if you want to isolate a texture to vertical cliffs or flat surfaces.

In this filter a determines the steepness of the noise (-4 is flat, 4 is vertical). The b variable controls the starting point of the transition.

- To place noise on vertical surfaces make $a=4$ and $b=2$.
- To place noise on flat surfaces make $a=-4$ and $b=1.5$.

The Slope filter works on the slope of an object in World Space.

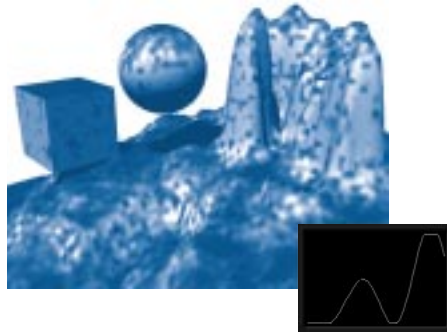

In this example, Slope was applied to RND Continuous noise and then to objects in a scene.

Altitude— $X(a * \text{Altitude} + b)$

This filter modulates the scale of the noise according to an object's altitude.

In this filter a determines how fast the noise is scaled by altitude. A lower value creates a gradual transition, while higher values create sharper transitions.

To apply noise at higher altitudes make sure a is positive. At high altitudes b controls the transition. The higher the transition, the lower the number. So, at high altitudes b should be a negative number.

To apply noise at lower altitude, reverse the variables so that a is negative and b is positive.

The Altitude filter works on the altitude of an object in World Space.

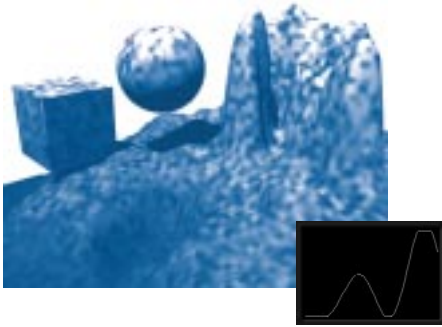

In this example, Altitude was applied to RND Continuous noise and then to objects in a scene.

Orientation— $X(a * \text{Orientation} + b)$

This filter applies noise based on an object's east-west orientation.

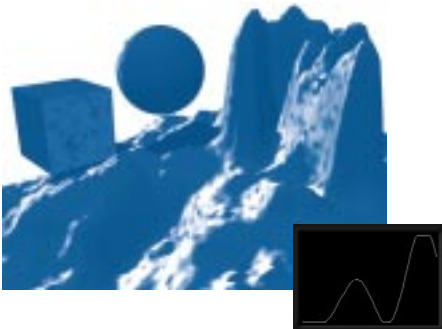

In this example, Orientation was applied to RND Continuous noise and then to objects in a scene.

Smooth Clip

This filter works exactly like the Clip filter. It's also a contrast filter, except that this filter smooths out the transitions between darks and grays.

The a variable controls the contrast and b controls the overall brightness.

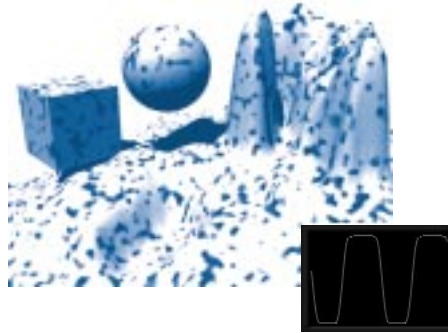

In this example, Smooth Clip was applied to RND Continuous noise.

Snow Puddles

This filter turns noise into snow patches. Snow is applied according to an object's slope and altitude.

The a variable controls how much the noise interferes with the smoothness of the snow. When $a=0$ the noise doesn't interfere at all so the snow is perfectly smooth. When the a value is higher, the snow starts looking like the noise.

The b variable shifts the altitude or snow level. It sets where the snow begins.

The c variable controls how steep an object has to be before the snow appears on its surface.

The higher the number, the flatter an object has to be before snow appears on its surface.



In this example, Snow Puddles was applied to RND Continuous noise and then to objects in a scene.

Combining Components

The Deep Texture Editor gives you unparalleled control over the look and feel of each one of the components that make up a texture, but the control doesn't stop there. The Deep Texture Editor also lets you control how those components are combined to create the final texture.

Blend Modes

Components are combined using Blend modes. These modes are filters applied to the components to determine how the properties in each component are combined with the other components' properties to form the final texture.

The number of blend modes you can use varies depending on how many components you're using to build the texture.

If you're using only one component, the properties in the component are applied directly to the final texture. When you're using two components, they're blended using a single

blend mode, and the result is then applied as the final texture.

When you're using three components, the first two components are blended together using a blend mode, then the result of that blend is combined with the third component using a second blend mode. The result of all the blending is then applied as the final texture.

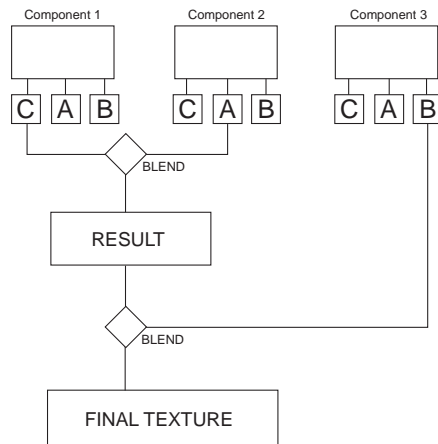

This diagram explains when the blend modes are applied as you combine components to form a texture.

Depending on the Blend mode, the different types of output can affect each other during the combination process. So it's possible that the Bump output of one component may affect the Color output of another.

To apply a blend mode:

- 1 Display the Deep Texture Editor.
- 2 Click the Arrow between components and choose a mode from the menu.



The arrows between components in the Deep Texture Editor provide access to the Blend Modes menu.

- Click the arrow on the left to choose a Blend Mode to combine components 1 and 2.
- Click the arrow on the right to choose a Blend Mode to combine the results of Component 1 and 2 with 3.

There are nineteen blend modes you can use to combine your components:

Parallel

This mode does not blend components. Use it when each component has a different output type. If two components share an output type, only the first output will be applied to the final texture.

For example, if Component 1 has output=Color and Bump, and component 2 has output=Color and Alpha, only the color from Component 1 will be applied to the texture.

Combine

Combine is a blend mode for colors only. When you use this blend mode, the first color in Component 2 is used as an alpha channel. Wherever that color appears in Component 2, it is replaced with the colors from Component 1.

For example, lets say Component 2 has Yellow, Green and Blue and Component 1 has Orange, Purple and Black as its color scheme.

When you combine them using the Combine blend mode, Yellow disappears from Component 2. Everywhere that Yellow appeared, you'll see Orange, Purple and Black.

Average

Average is normal blend mode where all the component values are mixed with equal weight.

So if one component is white and the other is black, the result is gray.

This is a good all-purpose blend mode to use for creating textures.

Multiply

When you use this blend mode to combine components, you'll get a darker result. In this mode, when a black component is combined with a gray component, the result is black. When a gray component is combined with a white component, the result is gray. When two shades of gray are combined, the result is proportionally darker.

In the case of Bump output, this mode will flatten most areas since black is flat and darker values create flatter bumps.

Maximum

When two components are combined using Maximum, the two components are compared and the one that's lighter becomes the result.

Blend Maximum

Blend Maximum works the same as Maximum, except that it creates blurring at points of sharp transition.

When Blend Maximum is applied to Bump output, the resulting bump map will have many high points and few deep pits.

This mode works best on Bump output.

Minimum

This mode is the opposite of Maximum. When two components are combined, they're evaluated and the darker areas of both are combined to produce the result.

Blend Minimum

Blend Minimum works the same as Minimum except that it creates blurring at points of sharp transition.

When Blend Maximum is applied to Bump output, the resulting bump map will have mostly low areas with very few high points.

Add

Add combines colors so that they appear dramatically lighter. However, it doesn't have the same effect on Bump output.

Subtract

When you combine grayscale components using Subtract, they tend to turn out black or very dark. When you use it with colored components, the result is brilliant colors that tend to compliment the original colors.

Blend v1 and v2

These two blend modes let you use one of the components as an alpha channel for blending.

When you choose Blend v1, the noise in the first component is used as an alpha channel to blend the two components.

When you choose Blend v2, the noise in the second component is used as an alpha channel to blend the components.

Blend Slope

Using Blend Slope, components are combined according to an object's slope. The first component is applied to areas that are flat and the other is applied to areas that are steep.

Fast Slope

Fast Slope works exactly like Blend Slope except that the transition from one component to the other is more abrupt.

Blend Altitude

This mode blends components according to an object's altitude. The first component appears at low altitudes and the second appears at high altitudes.

Blend Orientation

In this mode, one component is applied in all directions, while the other is applied in only one direction. You can use this mode to simulate things like moss that only grow on one side of a tree.

Blend Random

This mode introduces an extra layer of noise and uses it as an alpha channel for combining the two components. Component 1 appears in some areas of the new noise, and Component 2 appears in other.

Since this mode adds another layer of noise, you're also adding more processing time.

Procedural Blend

Procedural Blend combines two components so that the color and values of Component 1 are applied to Component 2 based on the gray values in Component 2. In essence, the Alpha output from Component 2 is used as a guide for blending.

Where Component 2 is light, Component 1 is not applied. Where Component 2 is dark, Component 1 is made darker. Where Component 2 is gray, Component 1 is applied without change.

This mode usually results in more saturated colors.

Difference

Difference finds the difference between the noise in the two components and displays the result.

This mode only works on output of like types. So if Component 1 has Alpha and Color output while Component 2 has only Alpha, the two Alpha outputs are combined and the Color output is left unchanged.

Global Changes

The component window in the center of the editor, called the Combination component, represents the final combined texture. Any changes you make to this final component are considered global changes since they affect the entire texture.

The Combination component can have its own color scheme, filter, noise pattern or phase. These attributes are applied to all the component elements. For example, the Combination noise values affect the noise within each component.

Global changes give you a way of applying a last layer of complexity to your texture.

Global Colors

The colors in the Combination component interact with the combined colors in the three components. They act as a final color filter for

the texture. After the colors in each component are combined, they are blended with the combination component colors to produce the colors in the final texture.

You can also apply a final Color Blending method to the combination component. The Blending method you apply to the combination component is applied on top of the other modes used in the components.

For example, if you choose Altitude in the Combination component, the texture color is applied using the blend modes in the components and then also applied by altitude.



This example shows a texture containing a texture with different Color Blending modes in it.

To add colors directly to a texture:

- 1 Click the top color circle in the combination component window and choose a color from the palette.



The color circles in the Combination component window let you apply colors directly to the final texture.

- 2 Repeat for each of the other two color circles.

Global Noise

When you change the noise in the Combination component, (i.e., globally) it applies to all the components equally. So if you increase the noise in the final component, the noise in each of the components increases. Likewise, when you decrease the noise globally, the noise in each individual component decreases.

Global noise can be different than component phase, so you can introduce a completely different type of noise into the texture.

Use this option cautiously. The more noise you introduce into your texture, the longer it takes to render and draw. If you introduce too much complex noise patterns into a texture, you may find your render time increased significantly.

You can adjust global noise in the same way you would for a single component, using the Noise palette or the Noise editor.

To adjust noise globally:

- 1 Click the top left button in the combination component window.

The Noise palette appears.



The three buttons along the outside of the Combination component window let you access the editing palettes.

- 2 Drag the slider to adjust the noise value.
- or

Click the top left corner of the Noise palette to display the Noise Editor.

- Use the editor's controls to design the global noise pattern or grain.

Global Phase

As you adjust the Global Phase value, new phase is introduced into each of the components.

Global phase can be different than component phase, so you can introduce a completely different type of phase into the texture.

You can adjust global phase in the same way you would for a single component using the Phase palette or the Phase Editor.

To adjust phase globally:

- 1 Click the bottom-right button in the combination component window.

The Phase palette appears.



The bottom-right button on the outside of the Combination component window accesses the Phase palette.

- 2 Drag the slider to adjust the phase amplitude.

or

Click the top left corner of the Phase palette to display the Phase Editor.

- Use the editor's controls to design the global phase.

Global Filtering

The Filter affects the final look of the noise within a component. The Global Filter affects the look of the combined noise. The Global Filter is applied to the noise in the Combination component.

The global filter only affects the noise, not the phase in the component. Any of the filters you used in the components can be used as the global filter.

Use this option cautiously. The more complex the noise in your texture, the longer it takes to render and produce. If you introduce too much complexity, you may find your render time increased significantly.

To filter noise globally:

- 1 Click the top-right button in the combination component window.
The Filtering palette appears.



The top-right button on the outside of the Combination component window accesses the Filtering palette.

- 2 Choose a filter and adjust its variables to create the desired effect.

The Deep Texture Editor

The Deep Texture Editor can be a source of incredible power or incredible frustration. It all depends on how you jump into it.

The editor can be used in two ways. If you're comfortable with equations and algorithms, it

gives you the freedom to create any textural pattern or surface you can imagine. If you're not so mathematically inclined, playing around with these deep functions can get you lost rather quickly.

For those who don't want to learn to calculate and postulate, the Deep Texture Editor can be used as a large palette. Take a little of this and little of that, blend them all together and see if you like the result. If it's a magnificent work of art, keep it; if not, discard it.

The only real penalty you may encounter when using the Deep Texture Editor unawares, is that you may inadvertently create a very complex texture that could add considerably to your rendering time. This is an easy pitfall to avoid however. The last section of this chapter gives you some tips on reducing the complexity of your textures. Refer to "Tips for Speeding Up Textures" on page 276 for more.

Before you start creating textures, you may want to familiarize yourself with this incredible tool.

Tip: When you're just exploring the editor, set all the component outputs to Alpha. This lets you see the effects of your changes more clearly.

To display the Deep Texture Editor:

- 1 Display the Materials Lab.
- 2 Click the A, B or C column of the material channel to which you want to assign a texture.
A component window becomes active.
- 3 Click the pink button at the top of the Component window.
The Deep Texture Editor appears.

A Quick Tour: The Deep Texture Editor

The layout of the Deep Texture Editor is a visual representation of the texture creation process. The three components along the top combine to form the final texture, shown in the middle. The layout makes the editor very easy to use.

Along the top of the editor you'll see the preview options. These three icons let you choose how you want to display the component.



The three icons at the top of the editor let you choose a preview mode.

Below the preview control on the left, you'll see the component selector. This tool lets you choose the number of components you want to use to build your texture.

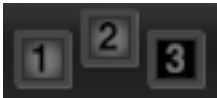

The component selector lets you choose how many components you want to use to build a texture.

The rest of the editor displays the component window. The three windows along the top represent the three components you can use in

a texture and the center window represents the combined texture.

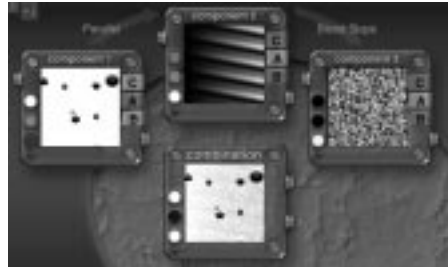

The three windows along the top of the editor represent the components, and the window in the center displays the final combined texture.

The arrows between windows represents the blend modes.

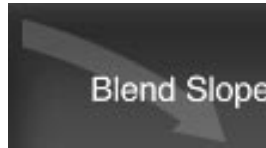

The arrows between components in the Deep Texture Editor provide access to the Blend Modes menu.

The three buttons along the bottom of the editor let you display the three editing palettes. The palettes let you control the noise, phase and filtering applied to the texture.



The three buttons along the bottom of the editor let you display the editing palettes.

You can access the Noise and Phase Editors from within the Noise and Phase palettes.

Working in the Deep Texture Editor

This section describes how to use the Deep Texture Editor to create and store textures.

Building Textures

A texture is a combination of components. You build textures by designing or editing components (i.e., colors, noise, phase or filters) and combining them using Blend modes.

To build a texture:

- 1 Display the Deep Texture Editor.
- 2 Click the Component Selector to choose the number of components you want to use to build the texture.
The component windows become active.
- 3 In the first component window, click one of the Output buttons to choose an output type.
- 4 If your component contains color, click one of the color circles and choose a color to apply to the texture.
You can choose up to three colors for each component.
- 5 Click the triangle icon below the color circles and choose a Color Blending mode for your colors.
- 6 Click the Noise button at the bottom of the editor. The Noise palette appears.
- 7 Adjust the noise in the component by:
 - Dragging the Noise slider on the Noise palette to increase or decrease the amount of noise in the component.

- Click the top left corner of the palette to display the Noise editor, then use the editor controls to design or edit the noise in the component.

- 8 Click the bottom-right button on the Component window. The Phase palette appears.
- 9 Adjust the phase in the component by:
 - Dragging the Phase slider on the Phase palette to increase or decrease the amplitude of the phase in the component.
 - Click the top left corner of the palette to display the Phase editor, then use the editor controls to design or edit the phase in the component.

- 10 Click the Filtering button at the bottom of the editor. The Filtering palette appears.
- 11 Choose a filter to apply the component noise and adjust that filter's variables.
- 12 Repeat steps 3–11 for each component in the texture.

As you edit the noise, phase, or filter of the remaining components, make sure you move the component indicator at the top of each palette to be sure you're editing the right component's attributes.



The component indicator at the top of each palette lets you know which component you're editing.

- 13 Click the arrow between Component 1 and Component 2 and choose a Blend mode from the menu.
- 14 If you have more than two components, click the arrow between Components 2 and 3 and choose a second blend mode.

The result of blending all the components appears in the Combination window.

- 15 Click the color circles in the Combination component window, and choose colors for the final texture.
 - You can also choose a Blending mode.
- 16 If you want to change the noise of combined component, display the Noise palette.

If it's already displayed, make sure the component indicator is on the fourth component.
- 17 If you want to change the phase of combined component, display the Phase palette.

If it's already displayed, make sure the component indicator is on the fourth component.
- 18 If you want to change the filter of combined component, display the Filtering palette.

If it's already displayed, make sure the component indicator is on the fourth component.
- 19 Click the OK icon at the bottom of the editor. The texture appears in one of the component windows in the Materials Lab.

Using Drag and Drop in the Editor

The Deep Texture Editor lets you drag and drop component elements between component windows. This is a quick way of copying elements between components.

For example, if you were setting up a red, green and blue separation of the colors in your texture, you could drag the same elements to all

three component windows and change the Color Blending mode.

To drag and drop between windows:

- Drag from the window you want to copy to the window where you want the elements to appear. Release the mouse button to drop the component elements.

The elements you drop into a window replace the existing elements.

Changing Component Preview

Each component window has a preview of the component's elements. You can choose to display the elements mapped onto a flat surface, a cube or a sphere.

Displaying the component on a cube makes it easier to see 3D noise and phase changes.

To choose a preview mode:

- Click the flat surface, cube or sphere in the top-right corner of the editor.



The three icons at the top of the editor let you choose a preview mode for the component windows.

Randomizing Textures

A quick way of designing a texture without going into designing noise or filters is to create random components.

The randomize buttons in the component windows let you randomize the elements in the component window. The type of output you choose for the component determines what part of the component is randomized.

This is an excellent way of exploring the editor. Just randomize the components elements and combine them to see what happens.

To randomize component elements:

- Click the knob in the bottom-right corner of the component window.



The knob in the bottom-right corner of the component window randomizes the elements in the component.

Undoing Changes

The Reset control lets you undo all the changes you've applied to a component and returns to the component displayed when you first entered the editor.

To reset a component:

- Click the knob in the top-left corner of the component window.



The knob in the top-left corner of the component window resets the component to the way it looked when you first opened the editor.

Saving Textures

You can save your texture as part of texture list so you can access it quickly from the Materials Lab.

To save a texture:

- 1 In the Combination component window, click the knob in the top-right corner of the component window.



The knob in the top-right corner of the Combination component window lets you save your texture.

The Save Texture dialog appears.

- 2 Enter a name for the new texture and click the OK icon.

The new texture appears at the bottom of the texture list. The list can be accessed from the Materials Lab.

Tips for Speeding Up Textures

Textures can be the most powerful effects you create in Bryce. They can also be the most costly. The more complex the texture, the longer it takes to calculate and the longer it takes to apply to an object, which finally increases the rendering time.

When you're creating the texture, you always have to keep in mind that it's part of a material, which is part of an object. All these parts can contribute to the rendering time:

- The material that contains the texture may have several complex attributes of its own, like Transparency and Reflection.
- The size of the object may also contribute to the rendering time.

Consider the effect of applying a complex texture to a complex material onto an infinite plane. The time to calculate this object would be staggering.

A good rule of thumb when working with complex objects and textures is to make the texture element as simple as possible.

These tips are meant only as a precaution to prevent you from inadvertently creating a huge texture. That doesn't mean that you shouldn't use the more complex features as well, after all they were created for a reason. You should just use them cautiously.

Noise

- Use a simpler noise type. Some noise types (like Vortex) require more time to process than others.
- Restrict the amount of noise you add to each component. In fact, not all the components need to have noise.
- Watch the frequency of the noise. Higher frequency noise requires more time to calculate than lower frequency noise.
- Watch the number of octaves in the noise. Each octave adds another level of complexity.

Phase

- When you're designing the phase, you may want to use simpler noise.
- Cut down on the number of phase types you combine. If each component has a

different type of phase, combining them can increase calculation times.

- Watch the amplitude of the noise. Higher amplitude phase takes much longer to calculate.
- Apply Global Phase cautiously. This is the quickest way of increasing the complexity of your texture because global phase introduces more complexity into each component simultaneously.

Filtering

- Filtering introduces complexity or detail into the noise of a component. Make sure that you aren't using a filter unnecessarily. Not all noise needs filters.
- Be careful when you apply a Global Filter as this adds even more complexity to the noise.



11

Arranging Objects

Arranging Objects in a Scene

In a scene, the arrangement of objects is as important as their form. You can design beautiful landscapes, or build complex models, but if they're the wrong size or in the wrong position, they won't look right in the scene. To get the right look, you'll need to position or rotate the objects to make sure they are in the right places within the scene, or you may need to resize an object so that it is in proportion with the rest of the objects. These kinds of operations are called *transformations*.

Bryce supports three basic types of transformations: size, position, and rotation. The tools in the Edit palette let you interactively perform these operations on any object in your scene. As well, the Object Attributes dialog lets you transform objects numerically for more precision.

As you arrange objects, you'll probably need to create some kind of object hierarchy. An object hierarchy lets you create a structure in

your scene that organizes objects according to their spatial or logical relationships. The structure can make arranging objects much easier and faster.

You can create an object hierarchy by grouping and linking objects.

This chapter describes how to use the transformation tools and the Object Attributes dialog to resize, reposition, rotate, align and randomize objects. It also describes how to create object hierarchies.

Bryce and 3D Space

Since all the objects in your scene exist in 3D space (defined by XYZ), any transformation you perform is a 3D transformation. This means that you're changing the attributes of the object in each axis.

Bryce has three ways of defining 3D space: World space, which is constant, Object space, which changes as the object changes and Camera space, which changes as the camera changes.

When you're using the interactive transform tools on the Edit palette you can use any one of the 3D space definitions. Refer to "Transformation Tools" on page 285 for more on using these tools.

World Space

World Space is the coordinate system that defines all the space in the Bryce universe. It is constant and cannot be modified. It is also the default space used for transformations.

World Space is defined by three axes, X, Y and Z, that all meet at world center. This center is defined numerically as 0, 0, and 0 for the X, Y and Z axes. By default, all new objects appear at world center.

The Y axis that extends from world center defines all vertical space. Positive values represent distances above ground level and negative values represent distances below ground. The X axis represents distances left and right and the Z axis represents distances backwards and forwards.

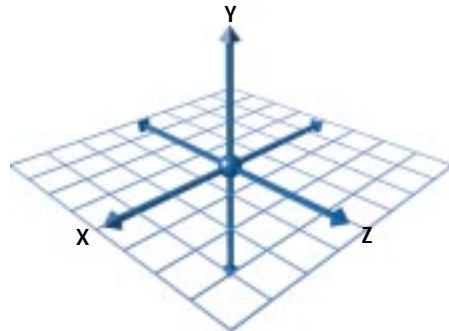

World space is defined by three axes that extend out infinitely from a center point called world center.

When you use World Space for transformations, objects move in relation to this absolute coordinate system.

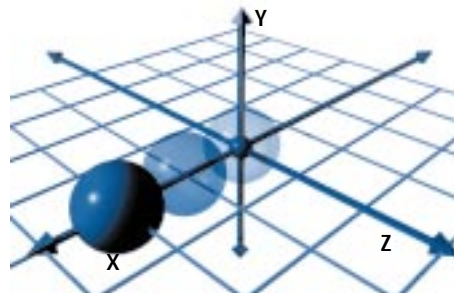

When you transform objects in relation to world space, they move along the three absolute axes.

Object Space

When Bryce creates an object, it defines the up, down, right, left, back and front of the object. These definitions remain with the object no matter what transformations you apply to it. So in a sense, each object carries with it its own coordinate system.

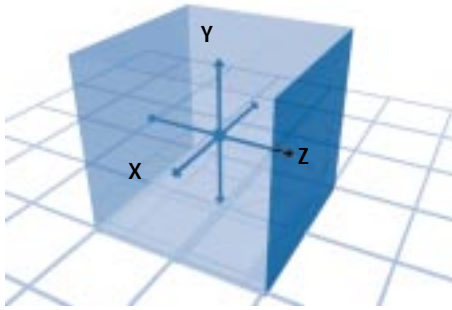

Object space is defined by three axes that extend out from the center of the object.

When you transform an object using Object space, the object moves in relation to its internal coordinate system. For example, you can increase the height of an object based on its own Y axis.

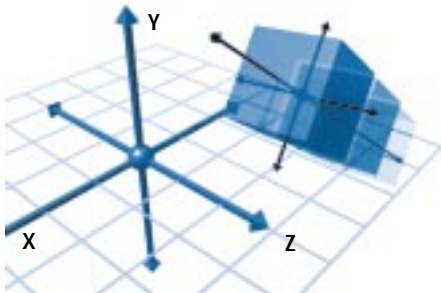

When you transform an object using Object space, it moves along an axis that extends from its center, not an absolute axis.

Because Object space ignores the absolute coordinates, the object becomes taller without being skewed. If you used World space, the object would become deformed since it increases along the absolute Y axis.

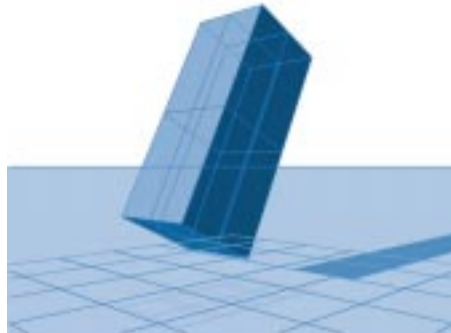
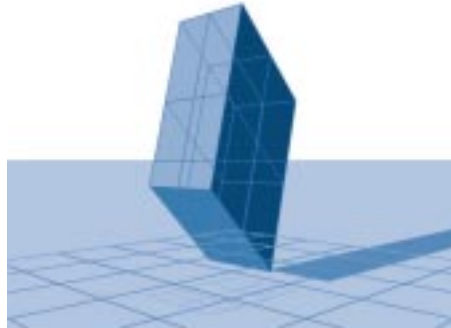

This is an example of an object transformed using World Space and then using Object Space.

Camera Space

Camera Space is defined by three axes, X, Y and Z, that extend out from the camera center. Wherever you move the camera, these axes move along with it.

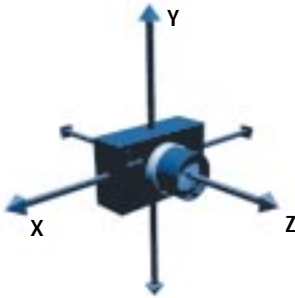

Camera space is defined by three axes that extend out from the center of the camera.

When you use Camera Space for transformations, you're moving objects in relation to the camera. When you drag along the X axis in camera space, you're moving left or right from the camera. When you move along the Y axis in camera space, you're moving up or down from the camera. When you move along the Z axis, you're moving away or towards the camera.

Since the camera can be rotated and repositioned, it can sometimes be hard to tell which way is up, left or right, because your view from the camera is no longer aligned to the absolute XYZ axes.

Suppose you've rotated the camera and then you move an object along the Y axis in World Space. Instead of moving up, it may appear to move off to the left, since your view of the scene is not aligned to the World Space Y axis.

However, in Camera Space, the object will move up, because the object moves along the camera's Y axis.

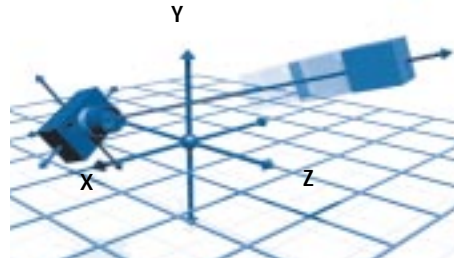

When you transform objects using Camera space, they move along an axis that extends from the center of the camera.

To choose a 3D spatial option for transformations:

- 1 Click the Edit button at the top of the Bryce window to display the Edit palette.
- 2 Click the triangle icon below one of the transformation tools and choose a 3D spatial option from the menu.



Each of the transformation tools has a triangle icon below it, which lets you access additional tool options.

Bryce Units

Bryce maintains an invisible, absolute, infinite 3D grid internally. This grid is comprised of 3D cube increments, each 2048x2048x2048 "Bryce units" in size. All primitive objects (spheres, cubes, etc.) are created at the same size as a 3D cube increment (2048x2048x2048) called *unity*.



Unity is the base size of all primitive objects created in Bryce. Unity is always 2048x2048x2048.

All interactive 3D transformations are relative to an absolute (unity) size, position, and orientation for all objects.

To reset object to unity:

- Hold down Command-Option/Ctrl+Alt and click one of the object's control points. The object is reset to 2048x2048x2048.

Coordinate Systems

When you're transforming objects numerically, in the Object Attributes dialog, you can use one of two coordinate systems: Absolute Coordinates or Object Coordinates.

Absolute Coordinates

Absolute Coordinates use the World Space axes as the reference for object transformations. When you enter transformation values using

Absolute coordinates, you're defining how the object is transformed along the World Space, or absolute, X, Y and Z axes.

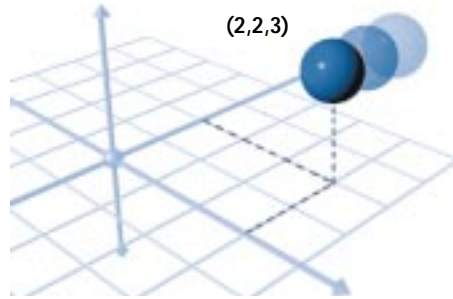

Absolute Coordinates use the World Space axes as reference, so you're repositioning the object along the absolute X, Y, and Z axes.

Object Space Coordinates

Object space coordinates define how an object is actually created. In object space, the origin of the object is located at $X=0, Y=0, Z=0$. All the other points in the object are defined by coordinates along the object's internal X, Y and Z axes.

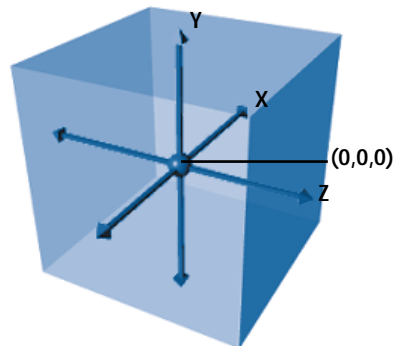

Object Space coordinates define how an object is created. The origin is at 0, 0, 0, while all the other points that define the object's shape and size are coordinates along the X, Y and Z-axes within the object.

This coordinate system uses the object's internal axes as a reference for transformations. When you enter transformation values using this system, you change how the object is defined, so that includes where its origin is positioned, its size, and orientation.

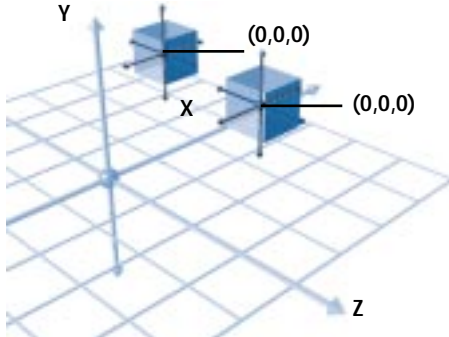

Object Space Coordinates use the object's internal axes as reference, so you're redefining the object's position along its internal X, Y, and Z axes.

In Object Space transformations, the origin point of the object always remains at Object Space 0, 0, 0. As you move or scale the object, it changes, moves or grows along its internal axes, but the origin remains at 0, 0, 0. This can cause some unpredictable results. For example, if you scale an object using Object Space coordinates, the origin point will no longer be in the exact center of the object, so if you rotate the object, it won't rotate around its center.

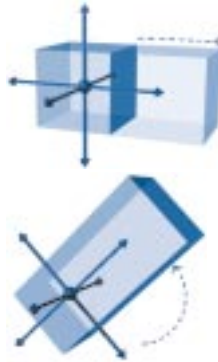

In this example, an object was scaled using Object Space coordinates and then rotated. You can see that it no longer rotates around its center.

Transforming using Object Space coordinates is not the same as using Object Space with one of the Transformation tools. When you choose Object Space for one of the transformation tools, transformations are performed using Object Space axes as a reference, but the final position, or size, is calculated using Absolute Coordinates. So in this case the object origin and all its points move along with the object.

When you use Object Space Coordinates to transform an object, you're redefining how the object is created, so its origin does not change as the size and position change.

Relative Coordinates

Relative Coordinates use the World Space axes as reference for object transformations, but the values represent changes relative to the object's current position, or size. For example, if you

enter a position change of 2 units, the object moves two units from its current position along one of the World Space axes.

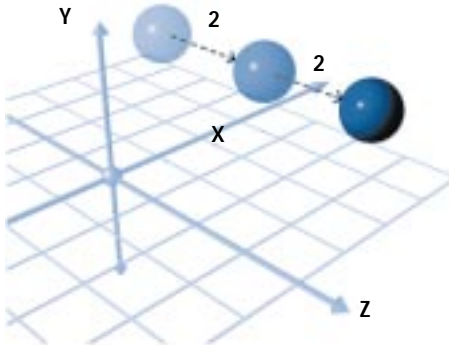

Relative Coordinates use the World Space axes as reference, but transformations are relative to the current position or size of the selected object.

Relative Coordinates are the only coordinate systems available in the 3D Transformation dialog.

Transforming Objects

Transformation Tools

The transformation tools let you perform all the object transformation operations available in Bryce. The tools act as interactive controls. As you drag over the tool, the operation is performed on the selected object.

The transformation tools are located on the Edit Palette.

To select a tool:

- 1 Click the Edit button at the top of the Bryce window to display the Edit palette.
- 2 Select an object.

- 3 Drag over the tool to perform a transformation operation.

Resize Tool



Use the Resize Tool to resize objects along one of the three axes.

Rotate Tool



Use the Rotate tool to rotate objects in 3D space.

Reposition Tool

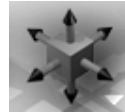

Use the Reposition tool to reposition objects along any of three axes.

Align Tool



Use the Align tool to align objects along their tops, bottoms, left sides, right sides, fronts, backs or centers.

Randomize Tool



Use the Randomize tool to scatter or disperse objects in 2D or 3D space.

Object Origin Points

Every object in Bryce has an origin point. This point defines the object's center of rotation.

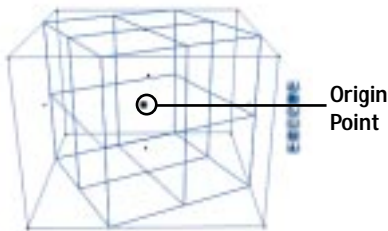

The object's origin point defines the object's center of rotation.

In the Working window, the Origin point appears as a small dot. By default the origin point appears at the center of the object's bounding box. You can adjust the position of the origin point to any point along the object's surface or outside of the object.

Where you place the origin point depends on the effect you want to create. For example, if you rotate an object when its origin point is at its center, it spins in place. When the point is placed outside the object, it rotates around the origin point like a planet around the sun.

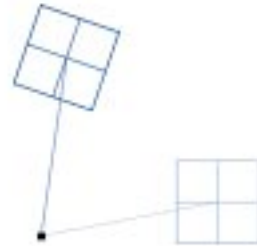
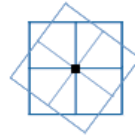

When the origin point is at the center of the object it rotates in place. When you move the origin point outside the object, it orbits around its point.

To display the origin point:

- Enable Show Origin Handle in the General tab of the Object Attributes dialog box.

To reset the origin point to the default position:

- Hold the shift key while clicking on the origin point of an object.

To set the origin point to the center of all the objects in the scene

- Hold Cmd/Ctrl+Shift while clicking on the origin point of an object

To cause the origin point to stay in position while the object moves

- Click, then hold, the spacebar while positioning an object with its origin point showing.

Nano-Edit Mode

Nano-Edit Mode activates the Nano-Editor which lets you perform transformations on a small preview of your scene, instead of the full scene.

When this mode is active, the Nano-Editor appears any time you perform a camera or object transformation. The Nano-Editor window displays a small preview of your scene. The transformation is applied to the preview. When you close the editor, the transformation is applied to the full scene.



Use the Nano-Edit mode to quickly see the effects of transformation on a preview of your image.

This mode is useful when you're working on a large scene, as it saves on redraw time.

To activate Nano-Edit Mode:

- Click the Nano-Edit button on the Display palette.



When the smaller square inside the icon (which represents an active Nano-Editor) is red, the Nano-edit mode is on; when it is white, it is off.

To temporarily activate Nano-Edit mode:

- Hold down Option-Spacebar/Alt + Spacebar before you perform transformations. The Nano-Editor appears only during the operation.

Resizing Objects

When you create an object, it appears at a default size. Once you place it in your scene you'll need to resize it make it proportional to the other objects in your scene. If the tree is larger than the terrain, one of them is at the wrong scale.

There are three ways of resizing objects in Bryce:

- Using the Resize tool, in the Edit palette, to resize an object along different axes.
- Using the 3D Transformation dialog which lets you enter precise values to resize objects.
- Using the control points on the object's bounding box to interactively resize the object.

Objects are measured in Bryce units. When you resize an object you're increasing or decreasing its size based on unity size. When you resize an object to 150%, you're sizing it to 150% of unity. Refer to "Bryce Units" on page 282 for more.

Using the Resize tool

The Resize tool lets you resize a selected object along any axis. Objects are resized from their origin point.

The Resize tool has seven different states. As you move the pointer over the tool each state becomes active.

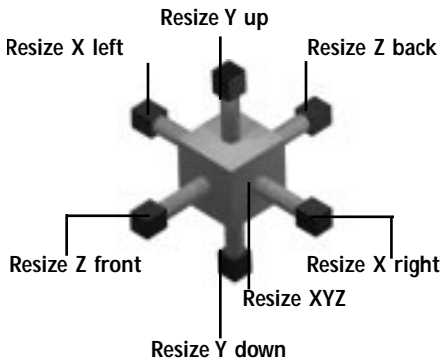

The resize tool has seven states. As you move your cursor over the tool each state becomes active.

The different states let you resize the object along different axes. Resizing along the Y axis increases/decreases the object's height. Resizing along the X axis increases/decreases the object's width. Using the Z axis for resizing increases/decreases the object's depth.

To resize an object along a specific axis:

- 1 Make sure the Edit palette is visible. If it's not, click the Edit text button at the top of the Working window.
- 2 Move the Cursor over the Resize tool.
- 3 When the state you want to use becomes active, drag to resize the object.

For example, if you're using Resize Y Up, drag to the left increase the object's height in the Y axis. The more you drag, the taller the object becomes.

Hold down Shift to constrain the resize increments to 50% intervals.

To resize an object in all directions:

- 1 Make sure the Edit palette is visible. If it's not, click the Edit text button at the top of the Working window.
- 2 Click the center of the Resize tool and drag left to increase the size of the object, or right to decrease it.

To resize an object from two directions along a single axis:

- 1 Make sure the Edit palette is visible. If it's not, click the Edit text button at the top of the Working window.
- 2 Move the cursor over the Resize tool.
- 3 When the state you want to use becomes active, hold down Option/Alt drag in the direction you want to resize the object.

For example, if you're using Resize Y Up, when you hold down Option/Alt as you drag, the object becomes longer both up and down along the Y axis.

Objects can be resized using any of the three spatial definitions (World, Object or Camera). The definition you choose depends on the effect you wish to create.

To choose a spatial option for resizing:

- 1 Make sure the Edit palette is visible. If it's not, click the Edit button at the top of the Bryce window.

- 2 Click the triangle icon next to the Resize tool and choose an option from the menu:



Object Space resizes your selection relative to itself (see “Object Space” on page 281).

World Space resizes your selection in absolute world coordinates (see “World Space” on page 280).

Camera Space resizes your selection relative to the camera (see “Camera Space” on page 282).

When you set Object, World, or Camera space for the Resize tool, it is also the option set for the other two transformation tools. However, spatial options are global for the transformation tools only. The option you select in the Edit palette does not affect the 3D Transformations dialog.

Flipping Objects

Flipping is not the same as rotating an object 180°. Flipping mirrors an object along an axis instead of rotating it.



Original object



Rotated 180° in X



Flipped in X

This example shows an object that has been rotated 180° and the same object flipped in X.

To flip an object:

- 1 Make sure the Edit palette is visible. If it's not, click the Edit button at the top of the Bryce window.
- 2 Click the triangle icon next to the Resize tool and choose a flip option from the menu:

Flip X inverts your object's dimensions along the X axis.

Flip Y inverts your object's dimensions along the Y axis.

Flip Z inverts your object's dimensions along the Z axis.

To undo resize operations:

- 1 Make sure the Edit palette is visible. If it's not, click the Edit button at the top of the Bryce window.
- 2 Select an object.

- 3 Click the triangle icon next to the Resize tool and choose Unscale from the menu.

Numerical Resizing

Sometimes you will need more precise control over the size of your object. The 3D Transformations dialog lets you enter specific resize values for a selected object.

All transformations you enter in this dialog are performed in World Space regardless of the spatial option you chose for the Resize tool.

Resize values are expressed as a percentage of the current size of the selected object. You can not enter negative numbers in this dialog.

To resize an object numerically:

- 1 Make sure the Edit palette is visible. If it's not, click the Edit button at the top of the Bryce window.
- 2 Select an object.
- 3 Click the triangle icon below the Resize tool and choose 3D Transformations from the menu. The 3D Transformations dialog appears.

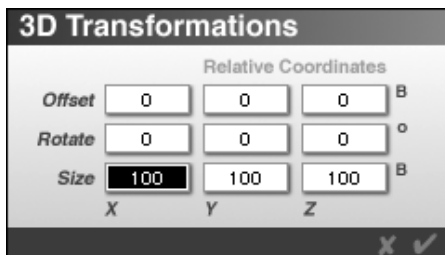

Use the 3D Transformation dialog to resize an object using numerical values.

- 4 Enter a percentage in one or all of the axis fields.

The percentage determines the new size of the object based on its original size. For example, to double the object's size in all directions, enter 200 in the X, Y, and Z fields. To resize along a single axis, enter values in only one axis field.

Since you are dealing with World Space transformations in this dialog, if you resize an object along only one or two axes you may unintentionally skew the object's shape.

To resize the object without skewing it, use the numeric entry fields in the Object Attributes dialog. Using this dialog can resize the object based on its original position, with no unintentional skewing. Refer to "Object Space Coordinates" on page 283 for more.

Interactive Resizing

While you can resize objects using the Resize tool or the 3D Transformation dialog, there are resize controls on the object's bounding box that let you resize objects directly in the Working window. You may find this a much more intuitive way of transforming your objects.

When you select an object, a bounding box appears surrounding your selection. At each corner of the box, and at the center of each face, is a control point.

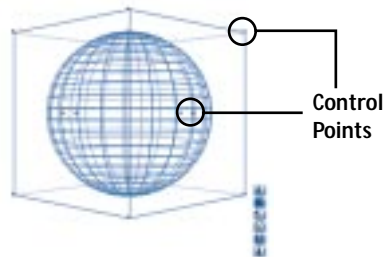

An object's bounding box has control points at the corners and at the center of each face that can be used to resize the object.

As your cursor passes over the corner control points, it changes to a generic Resize cursor. As it passes over the control points on the faces, it changes to an X, Y or Z. This indicates the axis along which you can resize the object by pressing and dragging at that point.

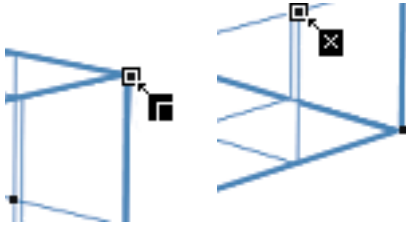

The corner control points resize the object along all three axes. The control points on the faces of the bounding box resize the object along a single axis.

To resize an object along a single axis interactively:

- 1 Select an object.
- 2 Drag one of the control points at the center of a bounding box face.

As you pass your cursor over the face, the cursor changes to an X, Y or Z to indicate the axis you're resizing along.

To enlarge or shrink an object interactively:

- 1 Select an object.
- 2 Drag one of the control points on the corners of the bounding box.

Drag right to enlarge it, or left to shrink the object.

- Hold down Command/Ctrl while dragging to resize in the opposite direction from the selected corner point.
- Hold down Option/Alt while dragging to resize from the center of the object.

- Hold down Shift to constrain resizing to 50% increments.

To resize an object from the bottom center:

- 1 Select an object.
- 2 Click the Y facial control point and hold down the mouse button, then press Command-Option/Ctrl+ Alt and drag the point.

The object resizes in all directions from the bottom center of the object. This transformation may be useful if the object is on the ground and you want it to remain there.

Using the Keyboard

You can also use the keyboard keys to resize objects:

*doubles a selected object's size.

/halves a selected object's size.

=returns the object to unity size and snaps it to the Grid.

Rotating Objects

Most objects have a specific up, down, left, right, back and front associated with them when you create them. When you place the object in a scene, its orientation may need to be altered to achieve a desired effect. For example, an airplane that's taking off should be tilted upwards, or tilted downwards when it's landing.

There are three ways of rotating objects in Bryce:

- Using the Rotate tool to rotate an object along different axes.

- Using the 3D Transformation dialog, which lets you enter precise rotation angles.
- Using the object's control points to interactively rotate the object.

Using the Rotate tool

The Rotate tool lets you rotate a selected object along any axis. Objects can be rotated in World Space, Object Space or Camera space.

The Rotate tool has three different states. As you move the pointer over the tool, each state becomes active.

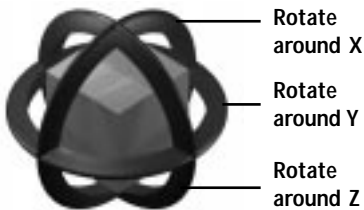

As you move your cursor over the tool each rotation state becomes active.

To rotate an object around a specific axis:

- 1 Make sure the Edit palette is visible. If it's not, click the Edit button at the top of the Bryce window.
- 2 Move the cursor over the Rotate tool.
- 3 When the state you want to use becomes active, drag in the direction you want to rotate the object.

Hold down the Shift key while dragging to constrain rotation operations to 45 degree increments.

You can rotate an object using any of the three spatial options (World Space, Object Space, Camera Space.)

To choose a spatial option for rotation

- 1 Make sure the Edit palette is visible. If it's not, click the Edit button at the top of the Bryce window.
- 2 Click the triangle icon next to the Rotate tool and choose an option from the menu:

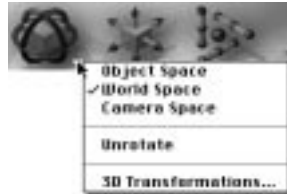

Object Space rotates your selection relative to itself (see “Object Space” on page 281).

World Space rotates your selection in absolute world coordinates (see “World Space” on page 280).

Camera Space rotates your selection relative to the camera (see “Camera Space” on page 282).

The three spatial options are also available for the Resize and Reposition tools. When you select Object, World, or Camera space for the Rotation tool, it is also set for the other two tools. Spatial options are global for all transformation. The option you choose in the Edit palette does not affect the 3D Transformations dialog.

To undo rotation operations:

- 1 Make sure the Edit palette is visible. If it's not, click the Edit button at the top of the Bryce window.
- 2 Click the triangle icon next to the Rotate tool and choose Unrotate from the menu.

Numerical Rotation

In a complex scene, orienting objects may require more precision than the Rotation tool offers. The 3D Transformations dialog lets you enter specific rotation angles for a selected object.

All transformations performed using this dialog use World Space coordinates regardless of the spatial option you chose for the Rotate tool.

Rotation values are expressed as degrees, with 360° being a single full rotation. Since rotations are relative, you may enter negative values and cumulative values (greater than 360° or less than -360°).

In this dialog, Bryce units have been transposed for the sake of simplicity. For instance, an object at Unity size of 2048x2048x2048 is seen in the 3D Transformations dialog box as 20.48x20.48x20.48.

Moving the decimal two points to the left lets you have a full range of resolutions without having to enter either excessive integer values or values with excessive places to the right of the decimal point.

To rotate an object numerically:

- 1 Make sure the Edit palette is visible. If it's not, click the Edit button at the top of the Bryce window.
- 2 Select an object.
- 3 Click the triangle icon next to the Rotate tool and choose 3D Transformations from the menu. The 3D Transformations dialog appears.

- 4 Enter a degree value in one or all of the Rotate fields.

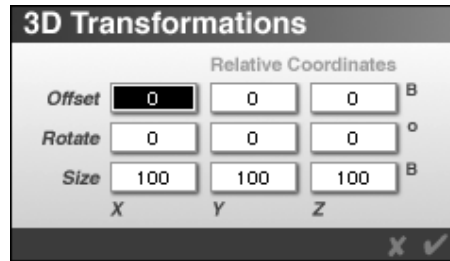

Enter a degree value in the Rotate fields to rotate objects by a specific angle.

The degrees determine the angle of rotation. For example, to rotate an object 45° around Y, enter 45 in the Rotate Y field. To rotate around other axes, just enter values in the appropriate fields.

Since you're dealing with World Space transformations, objects are rotated with respect to the World Space X, Y, and Z axes.

You can also rotate an object numerically using the Object Attributes dialog. The values in the Attributes dialog rotate the object using either Absolute coordinates or Object space coordinates. Refer to "Absolute Coordinates" on page 283 and "Object Space Coordinates" on page 283 for more on these coordinate systems.

Interactive Rotation

Using the control points on an object's bounding box, you can freely rotate an object directly in the Working window.

Rotation control points appear when you hold down Command /Ctrl and pass your cursor over the object's bounding box. The corner

control points let you free-rotate your object. The control points at the center of each face rotate the object along a single axis.

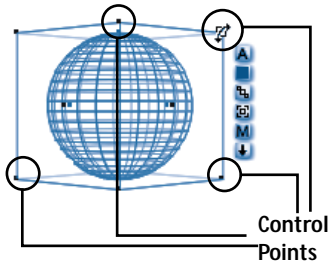

An object's bounding box has control points at the corners and at the center of each face that can be used to rotate the object.

To rotate around a single axis:

- 1 Select an object.
- 2 Hold down Command /Ctrl and drag on any face control point.
You can tell which axis you're rotating around by releasing the Command /Ctrl key for a moment. The cursor changes to an X, Y or Z.

To free rotate an object:

- 1 Select an object.
- 2 Hold down Command /Ctrl and drag on any corner control point.
 - Hold down Option/Alt to rotate in very fine increments
 - Hold down Shift to constrain rotations to 45° increments.

Positioning Objects

The composition of your scene depends on the position of the objects relative to other objects. In most cases, you'll need to use the Reposition tool in conjunction with the Resize and Rotation tools to create the desired relationships.

Positioning applies to objects, groups and families as well as lights and the camera. In this section the term "object" also refers to the camera and lights.

Bryce lets you position objects in four ways: using the Position tool to move objects along a specific axis, using the 3D Transformation dialog to enter specific offset positions, by dragging the object to a different location, or by using the arrow keys to nudge objects.

Using the Reposition Tool

The Reposition tool has six different states. As you move the pointer over the tool each state becomes active.

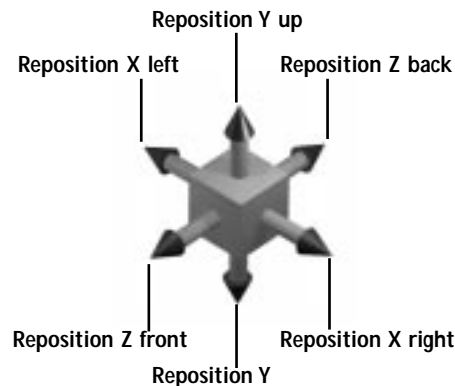

The rotate tool has six states. As you move your cursor over the tool each state becomes active.

To position an object along a specific axis:

- 1 Make sure the Edit palette is visible. If it's not, click the Edit button at the top of the Bryce window.
- 2 Move the cursor over the Reposition tool.
- 3 When the state you want to use is active, drag in the direction you want to move the object.

To choose a spatial option for repositioning:

- 1 Make sure the Edit palette is visible. If it's not, click the Edit button at the top of the Bryce window.
- 2 Click the triangle icon next to the Reposition tool and choose an option from the menu:

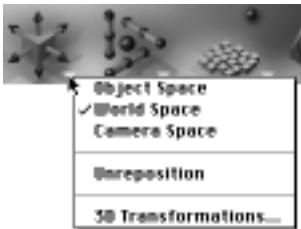

Object Space moves your selection relative to itself (see “Object Space” on page 281).

World Space moves your selection in absolute world coordinates (see “World Space” on page 280).

Camera Space moves your selection relative to the camera (see “Camera Space” on page 282).

The three spatial options are also available for the Resize, and Rotate tools. When you select Object, World, or Camera space for the Rotation tool, it is also set for the other two tools. Spatial options are global for all

transformation. The option you choose in the Edit palette does not affect the 3D Transformations dialog.

To undo position operations:

- 1 Make sure the Edit palette is visible. If it's not, click the Edit button at the top of the Bryce window.
- 2 Click the triangle icon next to the Reposition tool and choose Unreposition from the menu.

Numerical Repositioning

The most precise method of positioning objects is by using the 3D Transformations dialog. This dialog lets you enter specific offset values for a selected object.

All transformations performed using this dialog use World Space coordinates regardless of the spatial option you chose for the Reposition tool.

Offset values are expressed in Bryce units of measure (refer to “Bryce Units” on page 282). You may enter negative numbers in the Reposition fields.

In this dialog, Bryce units have been transposed for the sake of simplicity. For instance, an object at Unity size of 2048x2048x2048 is seen in the 3D Transformations dialog box as 20.48x20.48x20.48.

Moving the decimal two points to the left lets you have a full range of resolutions without having to enter either excessive integer values or values with excessive places to the right of the decimal point.

To reposition an object numerically:

- 1 Make sure the Edit palette is visible. If it's not, click the Edit button at the top of the Bryce window.
- 2 Select an object.
- 3 Click the triangle icon next to the Reposition tool and choose 3D Transformations from the menu. The 3D Transformations dialog appears.
- 4 Enter a value in one or all of the Offset fields.



Enter a value in the Offset fields to move objects by a specific number of units.

The value determines the number of Bryce units the object is offset from its current position.

Remember that since this dialog only performs transformations in world space, you are moving the object relative to world X, Y, and Z coordinates.

You can also position an object numerically using the Object Attributes dialog. The values in the Attributes dialog position the object using either Absolute coordinates or Object space coordinates. Refer to “Absolute Coordinates” on page 283 and “Object Space Coordinates” on page 283 for more on these coordinate systems.

Interactive Repositioning

The simplest way of positioning objects is by dragging them to different locations in your scene.

When you drag an object, you're repositioning it with respect to the camera.

To reposition objects by dragging:

- Pass your cursor over an object. When it changes to a crossed arrow, drag the object to a new location.
 - Hold down Command-Option / Ctrl+Alt while dragging to constrain movement to the X axis.
 - Hold down Option/Alt while dragging to constrain movement to the Y axis.
 - Hold down Command /Ctrl while dragging to constrain movement to the Z axis.

You can change modifiers mid-drag as you like.

Nudging Objects

Nudging lets you move objects by pressing the arrow keys and the PageUp and PageDown keys.

Nudging uses World Space coordinates to reposition objects. Each time you press a key, the object is moved in 1/4 unity size increments (512 Bryce units). Refer to “Bryce Units” on page 282 for more on Unity.

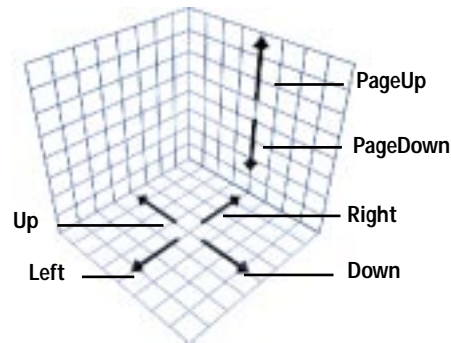

Use the Arrow, PageUp and PageDown keys to nudge objects in World Space.

To nudge an object along the X axis:

- 1 Select one or more objects.
- 2 Press either the Right or Left arrow keys.
 - Hold down Shift to nudge objects in 1/2 unity size increments (1024 Bryce units)
 - Hold down Option/Alt to nudge objects in 1/256 unity size increments (8 Bryce units).

To nudge an object along the Y axis:

- 1 Select one or more objects.
- 2 Press either the PageUp or PageDown arrow keys.
 - Hold down Shift to nudge objects in 1/2 unity size increments (1024 Bryce units)
 - Hold down Option/Alt to nudge objects in 1/256 unity size increments (8 Bryce units).

To nudge an object along the Z axis:

- 1 Select one or more objects.
- 2 Press either the Up or Down keys.
 - Hold down Shift to nudge objects in 1/2 unity size increments (1024 Bryce units)
 - Hold down Option/Alt to nudge objects in 1/256 unity size increments (8 Bryce units).

Aligning Objects

Bryce's alignment features let you position several object with respect to each other.

Alignment transformations are performed with respect to the Grid. Bryce maintains an internal grid that is comprised of 3D cube increments, 2048x2048x2048 Bryce units in size.



The Grid gives you a common reference for all alignment operations. If all your objects are at unity size you can use grid units to precisely align objects.

The Grid is used for Snap To operations and acts as common reference for alignment operations. One grid unit is equal to unity size, and unity position is always snapped to a position on the grid.

Using the Grid

The Grid can be used as a guide to help you precisely position objects in your scene.

The following example illustrates how the grid can be used to position a pyramid beside a cube:

To precisely position objects using the grid:

- 1 Make sure all the objects are unity size.
 - When you create primitives like cubes or spheres, they are unity size (2048x2048x2048 Bryce units).

- You can return existing objects to unity by holding down Command-Option/ Ctrl+Alt and clicking one of its control points.

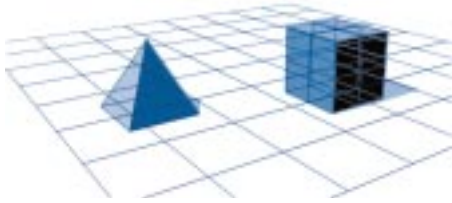

First, return all the objects you're aligning to unity, they fill exactly one grid unit...

This returns the objects to a perfect multiple of Bryce's grid units.

- 2 Determine the objects' positions relative to the grid.
 - When you create an object, it usually appears at World center or 0, 0, 0.
 - For existing objects, use the Snap to Grid option in the Edit palette to move the object to a point on the grid.

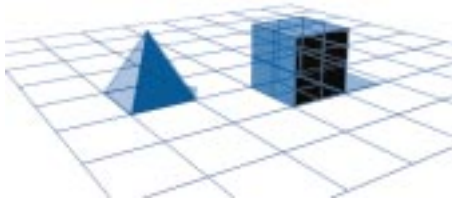

...then move the objects to grid using the Snap To Grid option...

- 3 Use the nudge controls to move the object. Nudging moves objects in grid increments.

To place the sphere precisely on top of the cube, press the up arrow four times. The cube moves up exactly 1 grid unit.

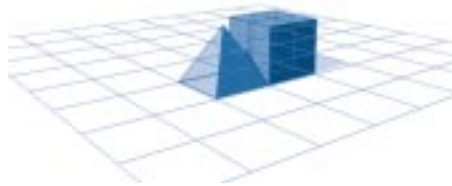

Finally, use the Nudge controls to move in precise increments along the grid.

Using the Align Tool

The Align tool has ten different states. As you move the pointer over the tool each state becomes active.

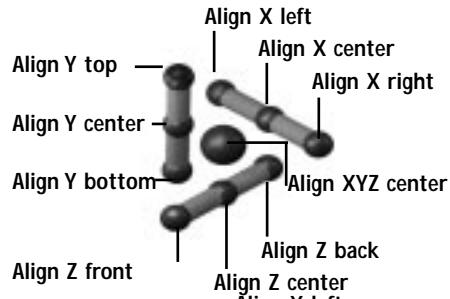

As you move your cursor over the Align tool each of its states becomes active.

To align objects along a specific axis:

- 1 Make sure the Edit palette is visible. If it's not, click the Edit button at the top of the Bryce window.
- 2 Select two or more objects.
- 3 Move the cursor over the Align tool.
- 4 When the state you want to use is active, click the mouse button.

Anchor Objects

An anchor object is the object in an alignment operation that does not move. All the other objects move in relation to the anchor object. The anchor object is the first object you selected.

Snap To Options

Bryce's snap to options let you automatically align objects to the grid, world center, ground or a land object.

To snap objects to the Grid:

- 1 Make sure the Edit palette is visible. If it's not, click the Edit button at the top of the Bryce window.
- 2 Select an object.
- 3 Click the triangle icon next to the align tool and choose Snap to Grid.
Refer to "Using the Grid" on page 297 for more on the grid.

To snap objects to the center of the anchor object:

- 1 Make sure the Edit palette is visible. If it's not, click the Edit button at the top of the Bryce window.
- 2 Select an object.
- 3 Click the triangle icon next to the align tool and choose Snap Together.
The X, Y, and Z centers of all selected objects are aligned the X, Y, and Z center of the anchor object in the selection.

To snap object to the World Center:

- 1 Make sure the Edit palette is visible. If it's not, click the Edit text button at the top of the Working window.
- 2 Select an object.
- 3 Click the triangle icon next to the Align tool and choose Snap to World Center.
The selected objects move to coordinate X=0, Y=0, Z=0, or World Center.

To drop or lift objects to ground level:

- 1 Make sure the Edit palette is visible. If it's not, click the Edit button at the top of the Bryce window.
- 2 Select an object.
- 3 Click the triangle icon next to the Align tool and choose Snap to Ground.

Landing Objects

The Land Selection align option lets you snap an object to any object directly below it, much like creating a gravity effect.

When you activate the Land Section option, Bryce looks snaps the selected object to the top of any object directly below its center “Y” control handle.



Using Land Selection, a selected object snaps to the top of any object that’s directly below its Y control handle.

The second object must be directly below the Y control handle, otherwise the object lands on the ground plane



In this example, a corner of the selected object is over the “land” object, but since there are not objects directly under its Y control handle, the selected object lands on the ground.

If the selected object is below the ground plane, it snaps up to the bottom of any object directly above its top center Y handle.



When the selected object is below ground, it snaps up to the bottom of an object directly above its Y control handle.

Landing operations work best with objects that have not been rotated, and that have no sloped characteristics.

This option can create many interesting effects. For example, you can quickly create falling rock animations by placing rock objects throughout your scene with a terrain below them in one frame. Then, in a different frame, select all the rocks and choose the Land Selection option. When you run the animation, all the rocks will appear to fall onto the terrain. Refer to “Animating” on page 353 for more on animation.



These objects were aligned using the Land Selection option.

To snap object to the top surface of an object below it:

- 1** Make sure the Edit palette is visible. If it's not, click the Edit text button at the top of the Working window.
- 2** Select an object.
- 3** Click the triangle icon next to the Align tool and choose Land Selection from the menu.

or

Click the Down arrow icon that appears next to the object's bounding box.

Anchor and Non-Anchor Based Aligning

Bryce provides two ways to align multiple objects: anchor-based aligning and non-anchor-based aligning.

Anchor-based aligning considers the first selected object to be the anchor of the aligning operation. All other objects are aligned to this object.

With non-anchor-based aligning, objects are aligned to the bounding box of all the selected objects.

Aligning Numerically

The most precise method of aligning objects is by using the 3D Transformations dialog. The dialog uses Bryce units for positioning, so you can use these increments to align objects based on grid increments (20.48=one grid unit).

In this dialog, Bryce units have been transposed for the sake of simplicity. For instance, an object at Unity size of 2048x2048x2048 is seen in the 3D Transformations dialog box as 20.48x20.48x20.48.

Moving the decimal two points to the left lets you have a full range of resolutions without having to enter either excessive integer values or values with excessive places to the right of the decimal point.

Randomizing Objects

The Randomize tool is a great way of randomly dispersing objects throughout your scene without having to manually position each object.

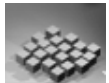

2D Disperse



2D Disperse/Rotate



2D Disperse/Size



2D Disperse/Size/Rotate



3D Disperse

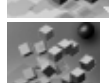

3D Disperse/Rotate



3D Disperse/Size



3D Disperse/Size/Rotate



As you click the Randomize tool each of its states becomes active.

Using the Randomize Tool

The Randomize tool has eight different states. When you click on the tool, it cycles through its different modes.

To randomize objects:

- 1 Make sure the Edit palette is visible. If it's not, click the Edit button at the top of the Bryce window.
- 2 Select a number of objects.
- 3 Click the Randomize tool repeatedly until the mode you want to use is active.

There are eight modes available:

2D Disperse scatters your selection randomly along the horizontal (X and Z) plane.

2D Disperse/Rotate scatters and rotates your selection randomly along the horizontal (X and Z) plane.

2D Disperse/Size scatters and resizes your selection randomly along the horizontal (X and Z) plane.

2D Disperse/Size/Rotate scatters, resizes and rotates your selection randomly along the horizontal (X and Z) plane.

3D Disperse scatters your selection randomly in 3D space.

3D Disperse/Rotate scatters and rotates your selection randomly in 3D space.

3D Disperse/Size scatters and resizes your selection randomly in 3D space.

3D Disperse/Size/Rotate scatters, resizes and rotates your selection randomly in 3D space.

- 4 Click the Randomize Sphere.
- 5 The selected objects are randomized.

To randomize objects interactively:

- 1 Select a number of objects.
- 2 Drag over the Randomize sphere. Release the mouse button when you achieve the desired effect.

Object Hierarchies

An object hierarchy lets you create relationships between objects, by grouping a linking object together.

A hierarchy adds structure to the objects in your scene. This can make arranging and animating objects much easier. When you're arranging objects a hierarchy can make positioning and rotating easier since you can transform an entire hierarchy all at once instead of separately. The same is true for animating. You can quickly create motion animations by changing the position of a parent object, since all its children will move with it.

Hierarchies can be created by either grouping or linking objects.

Grouping vs. Linking

Both grouping and linking let you create functional or spatial relationships between objects. The difference is how the objects within each hierarchy work. Within a group all the objects act as one. If one moves they all move. If one object is rotated, they all rotate. This type of hierarchy is good for creating complex objects with static parts, like a tree or a large terrain.

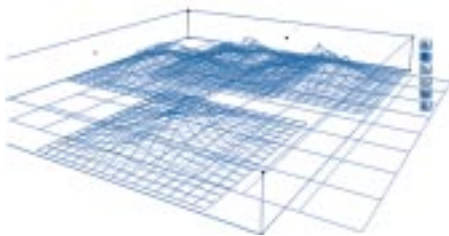

Group hierarchies are good for creating complex objects that have no moving parts like this terrain group. As you move the group all the objects in the group move.

Within a linked hierarchy objects behave differently depending on which object within the hierarchy is being transformed. Any transformation you apply to the parent object is applied to all its children. However, transformations applied to a child object do not affect the parent. This type of hierarchy is good for creating objects that have moving parts or animating two objects with the same motion.



Linked hierarchies are good for creating objects that have moving parts like this grandfather clock. As you move the parent all the objects in the hierarchy move, as the child moves the parent remains unchanged.

You can control exactly which transformations are applied to a child object using the options on the Linking tab in the Object Attributes dialog.

Hierarchical Structure

A hierarchical structure consists of a parent object or objects and its descendants. In the case of linking, the parent object is at the top of the hierarchy and its children are below it. Children in the hierarchy can also have children creating a branched hierarchy.

In a hierarchy created using links, the parent object is obviously the parent object in the link. The children are any object linked to the parent. If you have multiple linked objects in a

hierarchy, the parent object at the top of the hierarchy is the parent object in the first link you created.

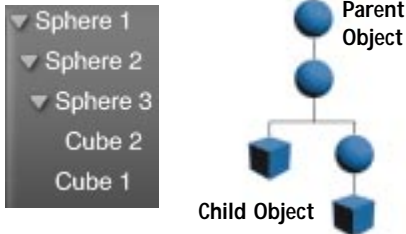

In this link hierarchy the parent object has one child and that child has two children one of which also has a child. So if you were to transform this hierarchy, any operation you perform on the Parent at the top of the hierarchy is applied to all its children.

In a hierarchy created using groups, the parent object is the group. All the objects within the group are the children. If you have multiple groups within a group, the parent object is the final group you create.

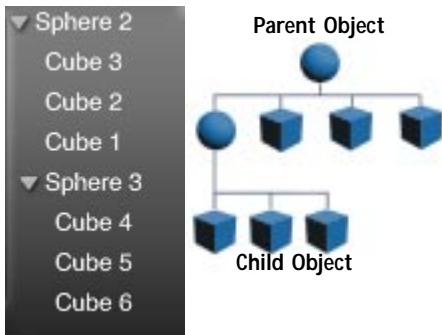

In this group hierarchy the parent group has four children one of which is a group that contains four children. If you were to transform this hierarchy, any operation you perform on the parent group would be applied to all the children.

A hierarchy can be made up of both linked and grouped objects. One way of creating this type of hierarchy is by grouping the parent objects

from different link hierarchies together. In this case, the final group you create would become the parent object of the hierarchy.

You cannot create a group using a child object. Only parent objects can be part of a group. When the parent is in a group all its children are also part of the group since they must follow the parent.

You could also create a hierarchy where a group is linked to a parent object. In this case, the parent object of the hierarchy would be the parent from the first link you created.

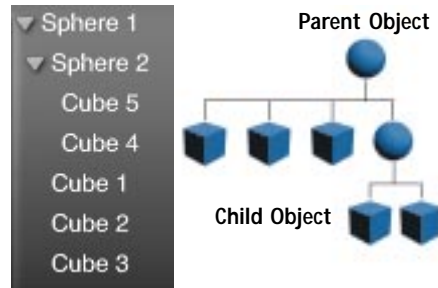

In this hierarchy the parent object is a group that has four children one of which is the parent object of a link hierarchy that has two children.

Viewing Object Hierarchies

The Hierarchy list area of the Advanced Motion Lab lets you see a list of all the objects in your scene. Object hierarchies are indicated by indents. A parent object is listed at the far left of the area; its children appear indented beneath it.

The name of an object that appears in the Hierarchy listing can be set using the Object Attributes dialog. If no name is set, a default name is used (for example Sphere 1).

These names are unique for each item in the scene, and are not reused regardless of the number of objects you create or whether the object has been deleted.

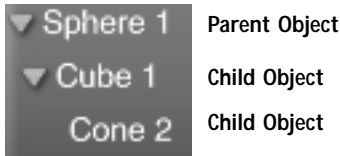

An indented listing indicates that there is a parent-child relationship between objects.

To view a listing of the hierarchy:

- 1 In the Working window, make sure there are no objects selected. This will let you see all the hierarchies in your scene.
- 2 Click the Advanced Motion Lab button at the bottom of the window. The Advanced Motion Lab appears.



The Advanced motion Lab buttons displays the Advanced Motion Lab where you can see the hierarchy listing for your scene.

The Hierarchy List area, located along the bottom-left side of the lab, displays all the hierarchies in your scene.

Expanding and Collapsing a Hierarchy

The arrow buttons next to an object's listing indicate whether the hierarchy is expanded or collapsed. A collapsed hierarchy shows only the parent objects in the hierarchy. An expanded hierarchy shows a listing for all the children.

Expanded Hierarchy

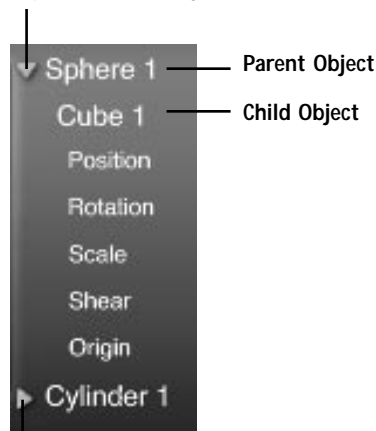

Collapsed Hierarchy

The arrows along the left side of the hierarchy list indicate whether the hierarchy is open or closed.

To expand/collapse a hierarchy listing:

- Click the arrow icon that appears next to a listing's name to expand it.
Click the arrow again to collapse the listing.

Linking Objects

When you link two objects, you connect them so that when one object moves, so does the other. This is called a *Parent/Child link*.

In a parent-child link, the parent controls the actions of the child. This means that when the parent object moves, so does the child object. However, when the child object moves, the parent object does not.

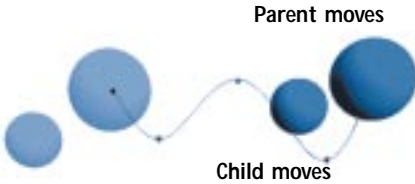

In a parent-child link, the movement of parent object dictates the movement of the child.

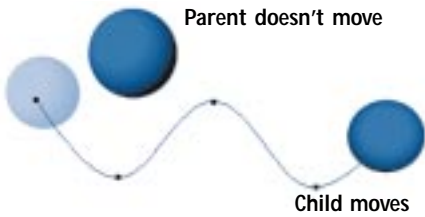

However, the parent object is unaffected by the child object.

A child object will start its movement from its original position and always maintain a constant distance from the parent. The distance is determined by the original positions of the objects before they were linked.

The movement of the child object depends entirely on the type of transformations you apply to the parent object.



If you rotate the parent, the child will orbit around it like a moon around a planet.



If the parent is moving along a path, the child will match the trajectory of the parent's path, but maintain a constant distance from the parent object.

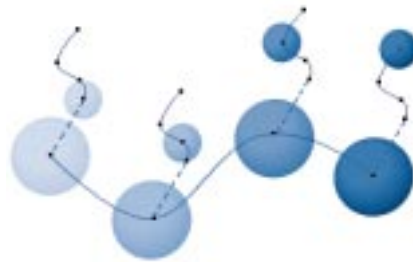

If both the parent and the child are moving along a path, the child object moves along its path while matching the trajectory of the parent object's path.

To link objects in the Working window:

- 1 Select the object you want to set as the child object. A series of icons appear next to the object's bounding box.

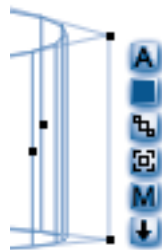

The icons along the right side of the object's bounding box let you interactively link objects.

- 2 Click the Link icon and drag the linking line to the object you want to use as the parent object.

You cannot create a link where the parent object is the child of its own child object (i.e.; a loop).

The parent object turns blue.

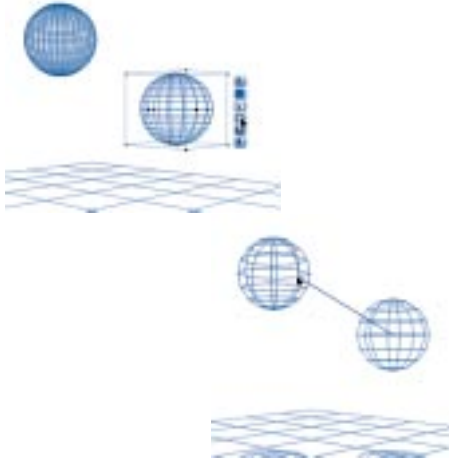

The object you select first becomes the child object. The object you drag the link line to becomes the parent object.

To link objects using the Object Attributes dialog:

- 1 Select the object you want to use as the child object.
- 2 Click the A icon that appears next to the object's bounding box. The Object Attributes dialog appears.

- 3 Click the Linking tab.

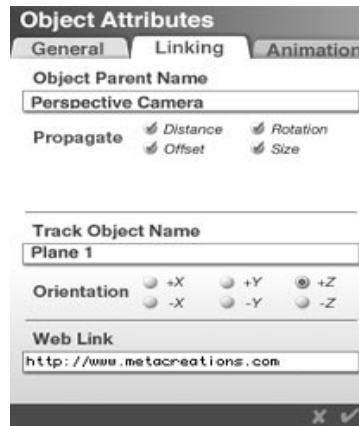

Use the options on the Linking tab of the Object Attributes dialog to setup the linking relationships between objects.

- 4 Click the Object Parent Name menu and choose the name of the object you want to use as the parent object.
- 5 Click the OK icon to link the two objects.

To break a link:

- 1 Select a child object.
- 2 Click the A icon that appears next to the object's bounding box. The Object Attributes dialog appears.
- 3 Click the Linking tab.
- 4 Click the Object Parent Name menu and choose None.
- 5 Click the OK icon to unlink the two objects.

Linking Options

Using the options available in the Linking tab on the Object Attributes dialog, you can control which parent object transformations are applied to child objects and how objects are constrained when they're linked to a path.

Parent to Child Transformations Options

Once you've created a link you can determine exactly which transformations applied to the parent will affect the child.

To set which parent object transformations are applied to a child:

- 1 Display the Object Attributes dialog.
- 2 Click the Linking tab.
- 3 Disable the buttons for the transformation you don't want applied to the child.

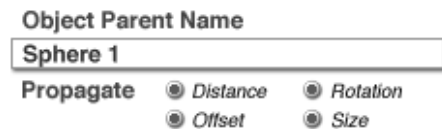

The enabled buttons on the linking portion of the Linking tab represent the transformations that will be applied to child object.

Geometric Path Linking Options

A Geometric path is an object that acts a kind of track for controlling the motion of objects. Normally when you link an object to a Geometric Path it is constrained to the path. However, using the linking options in the dialog you can disable or enable constraining.

When an object is constrained to the path, it can only move along the path. When its not constrained it acts like a regular child of the path. Its movement is not constrained to the path.

The options in this dialog also let you set where on the path a object begins its motion.

Refer to "Creating Geometric Paths" on page 117 for more on Geometric Paths.

To constrain/unconstrain an object to a geometric path:

- 1 Select an object linked to a geometric path.
- 2 Display the Object Attributes dialog.
- 3 Click the Linking tab.
- 4 Enable the Constrain to path button to constrain the object to the path.
 - Disable the button to unconstrain it.

To set where the object sits on the path:

- 1 Select an object linked to a geometric path.
- 2 Display the Object Attributes dialog.
- 3 Click the Linking tab.
- 4 Enter a percentage in the Position field.
 - 100% places the object at the end of the path, and 0% places it at the beginning.

Grouping Objects

As your scene becomes more complex you'll want to group objects. Grouping lets you control a set of objects as a single unit. When you perform a transformation on a group all the objects are equally affected. If you scale a

group, all the objects change size, or if you rotate a group, all the objects rotate around a single axis.

The objects you place in a group depend on how you want to organize your scene. You may want to group the objects that comprise more complex objects, like the walls and turrets of a castle.

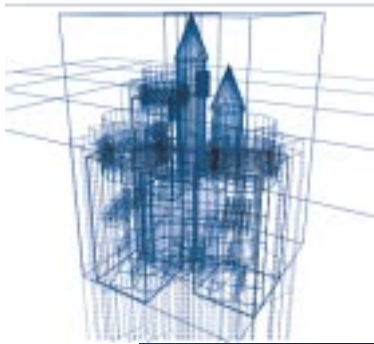

You can group objects to keep all the components of a complex object like this castle together.

You can also create groups to maintain the spatial relationships between objects as you transform them.



You can also create a group to maintain the spatial relationships between objects as you transform them, like the boards in this fence.

You can place as many objects as you like in your group. You can even nest groups within groups. Nesting can be an easy way of managing more complex scenes.

Groups are essential to creating Boolean objects. Boolean operations will not work unless the objects are part of a group. Refer to “Creating Boolean Objects” on page 114 for more on Booleans.

You cannot create a group using a child object. If a child object is part of your selection the “G” icon will not appear, meaning that you can’t create a group from the objects.

To create a new group:

- 1 Select all the objects you want to group.
- 2 Choose **Objects menu>Group**, or press Command/Ctrl-G. You can also click the G button next to the selected objects’ bounding box.



Click the G button next to a selection’s bounding box to create a group.

To select objects within a group:

- Hold down Control/Ctrl and click on the object inside the group bounding box.

Families

Families are a way of creating “logical groups.” Unlike regular groups, families are not treated as a single unit for transformations. Families help you keep track of elements in you scene, and can be used for selection purposes. For example, you can put all the elements that make up the background of your scene in to one family, all the items with a particular material in an another, all trees in another and so on.

Each family has a different object color. The color appears only when the object is not selected, since a selected object’s bounding box appears red.



You can easily see which objects belong to the same family when there no objects selected in the Working window.

To create a new family:

- 1 Select all the objects you want in the family.

- 2 Click the colored box next to the selection’s bounding box. The Family dialog appears.



Click the gray box next to a selection’s bounding box to create a family.

- 3 Click on a color. The color is applied to the bounding box of all the objects in the family.
- 4 You adjust these colors by dragging the rectangular color swatch at the bottom of the dialog. It’s best not to use black or white since they are difficult to see, or red since it’s the color of a selected object.
- 5 Enter a name for the family in the text field.

To select a family:

- 1 If the Animation controls are visible at the bottom of the Bryce window, click the Time Selection Palette toggle to display the Selection palette.
 - If there is nothing at the bottom of the window, move your cursor over the bottom area. The Selection palette appears.
- 2 Click the Family button and choose the name of the family you want to select from the menu.



The Families button in the selection palette displays a list of all the families in your scene.

A vertical blue-tinted photograph of a landscape. In the foreground, there is a grid floor with several benches and small, dark, tripod-like objects. In the middle ground, there are several tall, thin, conical trees. In the background, there are rolling hills and a clear sky.

12

Editing Objects

Overview

Every object in Bryce has attributes that allow you to control everything from its position in the scene to how it animates along a path. Some objects have special editors that are specifically designed to adjust the attributes that are unique to the object type.

This chapter describes how you edit object properties and also covers how to use the Torus and Mesh editors.

Restoring Objects

Every object in Bryce has a default size and shape. When you create an object, the default size is used to define its size and placement.

As you transform and edit objects these default properties are discarded and replaced. However, you can return an object to its original state at any time.

The restore control returns the object to its default size and orientation, regardless of the number of transformations you've applied to it.

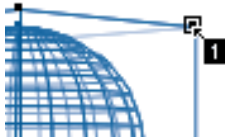

When you use the restore control, the cursor changes to a 1 when passed over the object's bounding box.

To restore an object:

- Hold down Control-Option/Alt+Shift (PC) or Control (Mac) and click one of the bounding box handles.

Editing Object Attributes

Every object in Bryce has several attributes that let you control the object's size, position, rotation, Boolean state, preview and whether or not it's locked.

There are two ways of editing an object's attributes: the Object Attributes dialog and the Object Controls that appear next to the object's bounding box.

Object Attributes Dialog

The Object Attributes dialog contains three tabs which let you set various object properties:

- **General** contains options that let you set the object name, position, size, rotation and display quality.
- **Linking** contains options that let you set up a link between two objects. You can also use this tab's options to set up a tracking link.
- **Animation** contains options for controlling the display of motion paths and setting motion path type.



Use the Object Attributes dialog to set transformation, linking and animation object properties.

To display the Object Attributes dialog:

- 1 Select an object.
- 2 Choose **Objects menu > Edit Attributes**, or press Command-Option-E/Ctrl+Alt+E, or click the A button next to the object's bounding box.

Object Attribute Icons

The Object Attribute icons appear as a list of buttons along the right side of an object's bounding box. The icons that appear in this list vary depending on the type and number of objects selected.

These icons let you:

- Access the Object Attributes dialog, the Material Composer and any editors associated with the object
- Group objects in a selection
- Add objects to families
- Align objects
- Link objects
- Set up object tracking



The Object Attribute icons that appear next to an object's bounding box let you access different editors and set object attributes.

If your selection falls outside of your Working window, the icons appear in the rightmost area available on the screen.

To display Object Attribute icons:

- Select an object or group of objects.

Object Attributes Icon



This control displays the Object Attributes dialog. When the dialog opens, it shows the cur-

rent name, position, orientation and scale of the object.

To display the Object Attribute dialog:

- 1 Select an object or group of objects.
- 2 Click the A icon that appears next to the object's bounding box.

Families Icon



This control indicates the family to which the object belongs. It also displays the Family dialog. Refer to "Families" on page 310 for more information.

To add selected objects to a family:

- 1 Select all the objects you want to add to the family.
- 2 Click the Family icon that appears next to the object's bounding box. The Family dialog appears.
- 3 Choose a color that represents an existing family, or enter a name to create a new family.

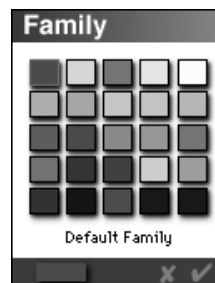

Use the Families dialog to add an object to an existing family or create a new one.

- 4 Click the OK icon. The color you select becomes the object's wireframe color.

Linking Icon



This control lets you set up a parent-child link between two objects. When the objects are linked, the transformations you apply to the parent object affect the child. Refer to “Linking Objects” on page 305 for more information.

To link one selected object to another:

- 1 Select the object you want to be the child object within the link.
- 2 Click the Link icon and drag it to the object you want to be the parent object. Release the mouse button when the parent object turns blue.

A link line extending from the child object to the parent appears as you drag.

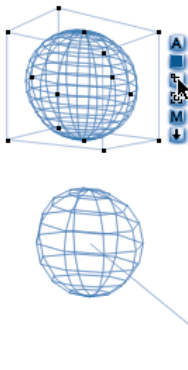

As you drag the Link icon, a link line extends from the child object.

Tracking Icon



This control lets you set up a Tracking link between two objects. When an object tracks

another, the selected object pivots as the target object changes position so it's always faces its target. Refer to “Tracking Objects” on page 382 for more on tracking.

To set a selected object to track another:

- 1 Select the object you want to be the stationary object.
- 2 Click the Tracking icon and drag it to the object you want to be the target object. Release the mouse button when the target object turns blue.

A tracking line extending from the stationary object to the target appears as you drag.

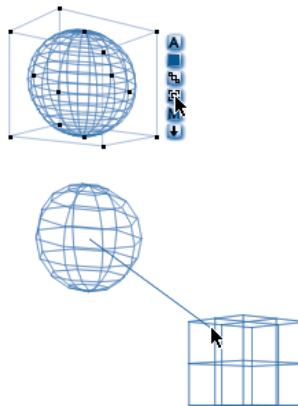

As you drag the Tracking icon, a tracking line extends from the stationary object.

Group Icon



This control appears only if your selection contains multiple objects. When you click this control all the objects in the selection are grouped. Refer to “Grouping Objects” on page 308 for more on grouping.

If this icon does not appear when you have a multiple selection, it means that you can't group the selected objects because of some kind of object hierarchy conflict. Refer to "Object Hierarchies" on page 303 for more information.

To group selected objects:

- 1 Select all the objects you want grouped.
- 2 Click the G icon that appears next to the object's bounding box. A group bounding box appears around all the objects.

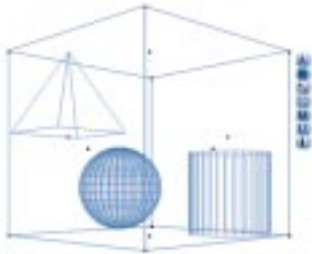

A large bounding box around a number of objects indicates a group.

Ungroup Icon



This control only appears if you've selected a group or a number of objects contained in a group. When you click this control, any group in the selection is ungrouped. If the selection contains nested groups, you can continue clicking this control until all the groups are ungrouped, or until the control disappears.

To ungroup a selected group of objects:

- 1 Select all the objects you want ungrouped.
- 2 Click the U icon that appears next to the object's bounding box.

Material Icon



This control displays the Materials Lab. Refer to "Materials" on page 189 for more on Materials. When you use this control, the Materials Lab displays the material currently applied to the selected object, and the object appears in the Material Preview area of the lab.

To display the Materials Lab:

- 1 Select an object or group of objects.
- 2 Click the M icon that appears next the bounding box.

Edit Object Icon



This control only appears if the object you selected is a terrain, a symmetrical lattice, a torus, a stone, an imported polyhedron object or a light. When you click this control, the editor for the object type you have selected opens.

To display an object's editor:

- 1 Select an object or group of objects.
- 2 Click the E icon that appears next to the bounding box.

Land Object Icon



This control appears as either an arrow pointing up or down, depending on the position of the object selected.

When you click this control, the object snaps to the top of the object below it. This control works like the Land Selection option available

in the Edit palette. Refer to “Landing Objects” on page 299 for more.

To land a selected object:

- 1 Select the object you want to land.
- 2 Click the Arrow icon that appears next to the object’s bounding box. The object snaps to the top of the object directly below it.

If the selected object is below ground, it snaps to the bottom of the object directly above it.

Editing Object Names

The Object Name field in the General tab of the Object Attributes dialog lets you name a selected object. An object’s name identifies it within the scene.

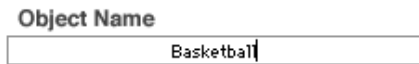

The Object Name Field lets you enter a name for the selected object.

When you have many objects of the same type, object names are used to select a specific object. The name is also used to identify an object in a hierarchy. Object hierarchies appears in the Hierarchy List area of the Advanced Motion Lab. Refer to “Object Hierarchies” on page 303 for more on hierarchies.

Editing Boolean Attributes

Boolean attributes, listed in the General tab of the Object Attributes dialog, control how an object acts in a Boolean operation. For exam-

ple, if a boolean attribute is set to Negative, the object subtracts an area from a positive object.



These are examples of some of the objects you can create using Boolean operations.

Refer to “Boolean Operations” on page 115 for a complete discussion of Boolean operations.

To set an object’s Boolean attributes:

- 1 Display the Object Attributes dialog.
- 2 Make sure the General tab is displayed.
- 3 Enable one of the checkboxes at the top of the dialog:

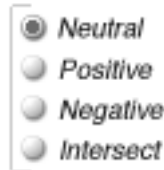

The four options on the top right side of the General tab let you set an object’s Boolean attributes.

Neutral defines any selected object, objects, or group as non-Boolean. No Boolean operation can be performed on a neutral object. This is the default setting for all objects

Positive defines any selected object, objects, or group as solid when grouped.

Negative defines any selected object, objects, or group as negative when grouped. Think of a negative object as a “cutting object.”

Intersect defines any selected object, objects, or group as an intersecting object when grouped.

Editing Display Quality Attributes

The display options available in the General tab of the Object Attributes dialog let you control how the object appears in the Working window. Some of these options can speed up the redraw of your scene.

- Hidden
- Locked
- Show As Box
- Show Origin Handle

The four options on the top left side of the General tab let you set how the object is displayed in the Working window.

Hidden

When you apply this option to an object, it is not rendered when you render your scene. The object remains visible in the Working window, where you can still select and edit it, but it will not be visible in the final render.

To hide an object:

- 1 Display the Object Attributes dialog.
- 2 Make sure the General tab is displayed.
- 3 Enable the Hidden button.

Locked

This option locks any selected object, objects, or group, preventing unintentional changes to size, position, rotation, or material assignment. Locked objects appear grayed-out in your wire-frame view.

To lock an object:

- 1 Display the Object Attributes dialog.
- 2 Make sure the General tab is displayed.
- 3 Enable the Locked button.

To unlock an object:

- 1 Click the Time Selection Palette toggle at the bottom of the Working window to display the Selection palette.



Use the Time Selection Palette toggle to switch between the Animation controls and the Selection palette.

- 2 Click an object type button or hold down the mouse while passing the pointer over an object type button and choose the desired object from the menu that appears.

Show as Box

This option displays any selected object, objects, or group as a box. This is useful when you just want to work with the object's position, but don't need more details. It can speed up work in a complex scene because it displays simpler objects. You can still manipulate your object using the bounding box control points.

To display an object as a box:

- 1 Display the Object Attributes dialog.
- 2 Make sure the General tab is displayed.
- 3 Enable the Show as Box button.

Show Origin Point

This option displays the selected object's origin point. Once its displayed, you can edit the posi-

tion of the point to change the object's center of rotation. Refer to "Object Origin Points" on page 286 for more on origin points.

To display an object's origin point:

- 1 Display the Object Attributes dialog.
- 2 Make sure the General tab is displayed.
- 3 Enable the Show Origin Point button.

Editing Transformation Attributes

The numeric entry fields on the General tab of the Object Attributes dialog describe an object's position, orientation, and size in 3D space. You can adjust these attributes by entering values in one or all of the numeric fields.

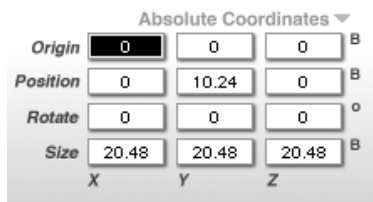

The Offset, Rotate and Size fields let you numerically transform the selected object.

The values in this dialog use either Absolute or Definition coordinates for transformations. Absolute coordinates use the World Space X, Y, and Z axes as a reference for transformations. Definition coordinates redefine how the object is created in Object Space. Refer to "Coordinate Systems" on page 283 for more on these coordinate systems.

Using Definition coordinates can create some unpredictable results because you're redefining the entire object when you change the Offset, Rotate and Size values.

To set an object's origin point:

- 1 Display the Object Attributes dialog.
- 2 Make sure the General tab is displayed.
- 3 Enter values in the Origin X, Y and Z fields.

To set an object's position:

- 1 Display the Object Attributes dialog.
- 2 Make sure the General tab is displayed.
- 3 Enter a value in the Position X field to set the object's position on the X axis. This axis moves the object left or right.
- 4 Enter a value in the Position Y field to set the object's position on the Y axis. This axis moves the object up or down.
- 5 Enter a value in the Position Z field to set the object's position on the Z axis. This axis moves the object backwards or forwards.

When you select multiple objects and access this dialog, there are no values displayed in the Position fields. If you then enter a value in any offset field, the selected objects are moved to the new coordinate, essentially aligning them in the same place relative to the designated axis or axes.

To rotate an object:

- 1 Display the Object Attributes dialog.
- 2 Make sure the General tab is displayed.
- 3 Enter a value in the Rotate X field to set the object's rotation around the X axis.

You can enter negative values, values greater than 360 or values less than -360. Bryce reduces the value to an absolute value within a range of 0-360.

- 4 Enter a value in the Rotate Y field to set the object's position on the Y axis.
- 5 Enter a value in the Rotate Z field to set the object's position on the Z axis.

To set an object's size:

- 1 Display the Object Attributes dialog.
- 2 Make sure the General tab is displayed.
- 3 Enter a value in the Size X field to set the object's size in the X axis.
You can enter negative values here if you need to.
- 4 Enter a value in the Size Y field to set the object's size in the Y axis.
- 5 Enter a value in the Size Z field to set the object's size in the Z axis.

When you select multiple objects and access this dialog, there are no values displayed in the Size fields. If you then enter a value in any Size field, the selected objects are scaled to the new coordinate.

Editing Link Attributes

Link attributes control how an object is linked to another. The controls on the Linking tab of the Object Attributes dialog let you set parent-child link attributes and tracking attributes.

Linking

When you link an object to another, you create a parent-child relationship. Transformations applied to the parent object affect the child, but transformations applied to the child object do not affect the parent. Refer to "Linking Objects" on page 305 for more on linking.

The Link options let you set the parent object for the selected object and choose which parent object transformations will affect the child.

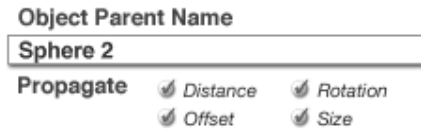

The Link options let you set up the attributes of a parent-child link.

To link objects:

- 1 Display the Object Attributes dialog.
- 2 Click the Linking tab.
- 3 Click the Object Parent Name field and choose a name from the menu that appears.
Choose None to break a link.
- 4 Enable a Propagate option. These options control which Parent object transformations affect the child.

Tracking

When you set up a tracking link, the stationary object tracks the target object as it moves or rotates. Whenever the target object moves, the stationary object pivots so that its always facing the target.

The Tracking options let you set the target object for the selected object and define which axis of the stationary object will face the target.



The Tracking options let you set the attributes for a link between a stationary object and its target.

To set an object to track another:

- 1 Display the Object Attributes dialog.
- 2 Click the Linking tab.
- 3 Click the Track Object Name field and choose a name from the menu that appears.
Choose None to break a tracking link.
- 4 Enable one of the Orientation options. These options set which object axis will track the target.

Editing Animation Attributes

Animation attributes control the display of an object's motion path. A motion path is a graphical representation of an object's trajectory over the course of the animation. Refer to "Motion Paths" on page 376 for more on motion paths.

The options on the Animation tab of the Object Attributes dialog let you control how an object's motion path is displayed in the Working window and how that path is drawn.

Motion Path Display Options

Normally, a motion path is displayed as it is being drawn and when the object is selected. The motion path display options on the Anima-

tion tab of the Object Attributes dialog let you control when the motion path is displayed.



The Motion Path Display options let you control when an object's motion path appears.

To set motion path display options:

- 1 Display the Object Attributes dialog.
- 2 Click the Animation tab.
- 3 Enable one or all of the display options:

Show Trajectory enables or disables the display of the motion path. When it is disabled, no motion path is drawn.

Show When Selected displays the motion path only when the object is selected.

Show Always displays the motion path at all times, even when the object is not selected.

Motion Path Attributes

When a motion path is created, it looks like a curve that extends out from an object. The motion path attributes let you display additional information on a motion path.



The Motion Path Attributes let you control the appearance of an object's motion path.

To set motion path attributes:

- 1 Display the Object Attributes dialog.

- 2 Click the Animation tab.
- 3 Enable one or all of the attributes:

Show Handles displays or hides the path's control handles. The handles represent key frames.

Show Tangents hides or displays lines extending from each control handle. Tangents help you see the slope of the curve.

Show as Ribbon displays the motion path as a flat ribbon in the working window. This makes the path easier to see when you move the camera.

Align Options

Normally, unless you apply a rotation, an object's orientation remains constant as it moves along a motion path. The align options let you force the object's orientation to match the slope of the motion path so that as the path curves up, the object tilts up.

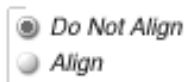

The Align options let you control how an object is aligned to its motion path.

To set align options:

- 1 Display the Object Attributes dialog.
- 2 Click the Animation tab.
- 3 Enable one of the following options:

Do Not Align disables aligning. The shape of the curve has no effect on the object's orientation. This is the default setting.

Align adjusts the object so that its orientation matches the shape of the path.

Motion Path Geometry Options

The shape of a motion path is determined by the position of the object as it moves through the animation. The motion path geometry options let you change the shape of the path to create different effects.

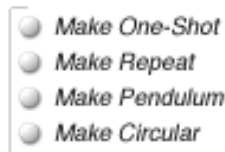

The Motion Path Geometry options let you control the shape of an object's motion path.

To set motion path geometry options:

- 1 Display the Object Attributes dialog.
- 2 Click the Animation tab.
- 3 Enable one or all of the options:

Make One Shot restores the path to its original shape, meaning the shape created by changes in the object's position.

Make Repeat creates a loop in the action. The motion on the path will continuously repeat.

Make Pendulum creates a repeating cycle in the action along a path. The object will move forward on the path and then back.

Make Circular closes the path to create a circular path. The object will move along the path until it reaches the end. It then swings around to the front of the path and starts over. You must have at least four position key frame points for this feature to work.

Editing Toruses

A torus object is any pre-made donut-shaped object in Bryce. The Torus editor lets you adjust the inner radius of any torus object.

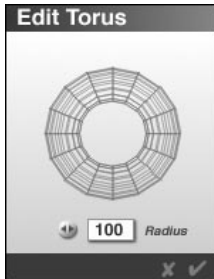

Use the Torus editor to adjust the inner radius of a torus object.

To display the Torus editor:

- 1 Click a Torus object.
- 2 Click the E button that appears next to the object's bounding box.

To adjust the inner radius:

- Press and drag on the spinning Torus. Release the mouse when the radius is the size you want.

To accept your changes and exit the Torus Editor:

- Click anywhere outside the Torus Editor, or press the Return/Enter key.

To exit the Editor without accepting any changes:

- Press the Escape key.

Editing Imported Meshes and Stones

Imported objects (such as DXF or 3DMF objects) and Bryce's Stone objects are both treated as meshes inside Bryce.

The Mesh Editor lets you adjust the smoothness of an object's surface. You can smooth objects that are very rough or remove the smoothing previously applied to DXF objects.

It is not a good idea to smooth or unsmooth Stones. These objects are highly dependent upon the clumpiness of the polyhedral shape as well as the bumpiness in the assigned procedural texture to retain their realism. Smooth stones look very unnatural.

To smooth imported objects or stones:

- 1 Click the imported object or stone.
- 2 Click the E button that appears next to the object's bounding box.
- 3 Adjust the value of the smoothing range by dragging the gauge along the left side of the dialog.

The gauge sets the maximum angle you wish to be smoothed.

For instance, you may wish to smooth all angles under 90° (to preserve the sharpness of cubes, perhaps). In that case, set the maximum angle to 85 before smoothing.

- 4 Click the Smooth button until you achieve the desired effect. The more you click, the smoother the object becomes.

To unsmooth imported objects or stones:

- 1 Click the imported object or stone.
- 2 Click the E button that appears next to the object's bounding box.
- 3 Adjust the value of the smoothing range by dragging the gauge along the left side of the dialog.

The gauge sets the maximum angle you wish to be unsmoothed.

For instance, you may wish to unsmooth all angles under 90°. In that case, set the maximum angle to 85 before unsmoothing.

- 4 Click the Unsmooth button until you achieve the desired effect. The more you click, the sharper the object becomes.

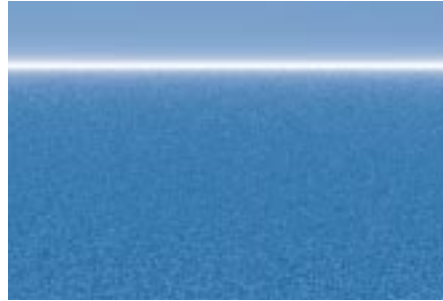

...to a rocky desert by converting the pyramid primitive into a plane.

Conversions cannot be animated. You can't have a box that turns into a cone over time.

Converting Objects

The Convert tool in the Edit palette lets you convert any type of object into another type of object with a single click. So you can change a square into a light, a terrain into a sphere, or an infinite plane into a cone.

Any transformations you applied to the original object are preserved through the conversion.

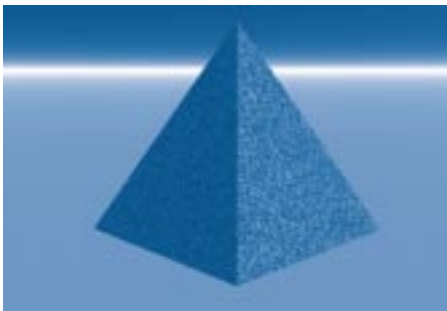

The Convert tool lets you quickly turn any object into any other. In this example, the object changed from an Egyptian pyramid...

To convert an object to another type of object:

- 1 Select the object you want to convert.
- 2 Click the Edit button at the top of the Bryce window to display the Edit palette.
- 3 Click the double-headed arrow in the top left corner of the palette and choose an object type from the pop-up palette that appears.



The pop-up palette that appears in the Edit palette displays all the object types you can convert your selected object to.



13

The Camera and Lights

The View of Your Scene and Lighting in Bryce

You can think of the view of your scene as the view seen through a window onto a whole new world. The view you see through this virtual window is determined by the orientation and position of a camera. As you move the camera, you get a different view of your world.

How much of the world is visible is determined by the lighting. The position of the light sources in your scene can determine everything from visibility to the time of day to the color of the atmosphere.

The View of Your Scene

The view of your scene refers to the portion of the scene visible in the Working window. There are eight views of your scene available in Bryce: the *Camera View*, which is the view produced by the Camera in the scene, the *Director's View*, which shows your scene from the perspective of a director sitting outside of the scene, and the *orthogonal projections* (Top, Bottom, Left, Right, Back and Front) which are perspective-free views of your scene.

Camera View

Camera View is produced by the Camera which exists in 3D space, meaning that you can view your scene from anywhere within your Bryce environment—even underneath it. The Camera View can be positioned using the positioning tools or by repositioning the Camera in the scene.

The Camera has a wireframe which can be dragged in the Working window and its motions can be recorded as an animation. However, the wireframe is only visible in the Director's View or one of the orthogonal views.

Director's View

The Director's View gives you the freedom to look at your scene from any perspective, while still being able to manipulate the Camera as an object.

The Director's View motions are not recorded as part of an animation. This means that you can move to any position without inadvertently changing the view of your scene in the animation. The Director's View can also be an invaluable tool for animating the view of your

scene. While in this view, you can select the Camera and reposition it anywhere in the scene to create camera motions.

Director's View is the default view of the scene.

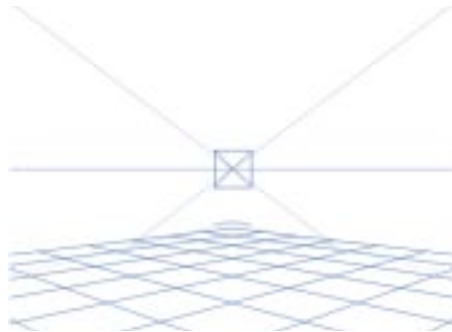

This is what your scene looks like when you view it in Director's View.

Orthogonal Views

These six views let you see the scene from all sides. They do not show you any perspective, but you can see all the objects in the scene including the camera.

These views are only flat projections of the scene, so you can't move around them using the camera controls.

Lights

Lighting is what makes your scene visible. Different types of lighting can dramatically alter the appearance of your scene and the objects in the scene.

In Bryce, most of the lighting in your scene is provided by either the sun or the moon. As in nature, the position of the Bryce sun controls the general brightness and ambient color of scenes. However, you can add additional light

sources to create a variety of effects, like adding headlights to a car, or creating the glare of a distant city.



You can use light sources to shine light from areas where sunlight couldn't shine, like the light from inside a lighthouse.

Refer to “Working with the Sun” on page 145 for more on positioning and setting up the sun.

Viewing Lights

In Wireframe mode, lighting effects are not visible. Instead, all objects are displayed as wireframes to make it easier and faster for you to edit and position objects. Lighting appears in three places: the Shaded Preview mode, the final rendered scene, or in the Nano-Preview.

In Nano-Preview, you can see a small preview of your lighting effects. This is the only preview available in Wireframe mode.

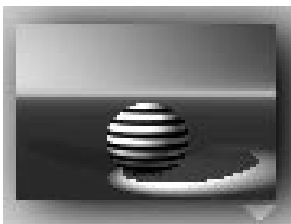

Lighting effects also appear in the Nano-Preview.

In Shaded Preview mode, all the objects in your scene appear as flat solids. Any lighting you apply creates simple highlights on the surface of the object. This mode does not show materials.



In Shaded mode the objects in your scene are displayed as solids. You can also see the effects of different lighting.

Shaded Preview mode is only available if you have a system that supports OpenGL. Refer to “Display Modes” on page 17 for more on this mode

If you want to see the effects of lighting on object materials, you’ll need to render the final image.



When you render your scene you can see the effects of light position and color on your object's materials.

Visible Lights

One of the most spectacular uses of light sources is visible light. Visible light effects are like cones of light that appear in your scene, like a searchlight cutting through the fog.



The effect of a searchlight cutting through the fog can be created using a visible light.

There are two types of visible lights: surface visible lights and volume visible lights.

Surface visible lights make the light object visible in the scene, but the light does not interact with the environment, so you get a light cone or sphere. Volume visible lights interact with the environment, affect all the objects that they strike, and are directly affected by environment color and brightness. For instance, volume visible lights can show shadows thrown through the air that the light illuminates. Surface visible lights cannot.



The volume visible light source interact with the other light sources in the scene.

Refer to “Creating Visible Lights” on page 348 for more on setting up surface and volume visible lights.

Setting Up the View of Your Scene

There are eight different views of your scene available in Bryce: Camera View, Director’s View, and the six orthogonal views. The Camera View and Director’s View let you see the scene from any perspective, while the orthogonal views let you see projections of the scene from the top, bottom, left, right, front and back.

Camera View

This view of your scene in the Working window is as seen through the lens of the Camera object in your scene.

Since your scene exists in 3D, you can view it from any vantage point: above, below, or even from inside an object. To see these different perspectives, you change the position of the

Camera. The positioning tools available in the Control palette let you position the Camera along specific axes and change its orientation.

As you create and position the objects in your scene, you can use the position and orientation of the camera (called Camera Space) as a reference for several transformation operations. You can rotate, position and resize objects using Camera Space. Refer to “Camera Space” on page 282 for more information.

When you’ve completed your scene, the Camera View can be used to create the final rendered image or animation. You can reposition the camera again and render the scene from several different viewpoints.

The camera can also be animated just like any other object. You can record changes in its position at different points along the timeline. When you run the animation, the view from your camera appears to change like the view seen from an airplane as it flies through a landscape. Refer to “Animating the Camera” on page 383 for more on animating the camera.

When you’re in Camera View, a small camera icon appears in the View control.



The camera icon in the View Control indicates that you’re in Camera View.

To switch to Camera View:

- Click the triangle icon next to the View Control icon and choose Camera View from the menu.
- or
- Click and drag over the View Control until the Camera icon appears.

Setting Camera Object Properties

Since the Camera acts as an object, there are several object properties you can use to set how it’s displayed, linked or animated.

Refer to “Editing Link Attributes” on page 319 for more on linking properties and “Editing Animation Attributes” on page 320 for more on Animation properties.

To hide the camera wireframe:

- 1 Switch to Director’s View or an orthogonal view so you can see the camera’s wireframe.
- 2 Select the camera in the Working window.
- 3 Click the A icon that appears next to it. The Camera & 2D Projection dialog appears.
- 4 Enable the Invisible option.
- 5 Use the Selection palette to re-select the camera once it is hidden. Refer to “Selection Palette” on page 12 for more information on reselecting the camera.

To display the camera’s field of view:

- 1 Switch to Director’s View or an orthogonal view so you can see the camera’s wireframe.
- 2 Select the camera in the Working window.
- 3 Click the A icon that appears next to the camera object. The Camera & 2D Projection dialog appears.
- 4 Enable the Show FOV option.

To lock the camera position:

- 1 Switch to Director's View or an orthogonal view so you can see the camera's wireframe.
- 2 Select the camera in the Working window.
- 3 Click the A icon that appears next to its bounding box. The Camera & 2D Projection dialog appears.
- 4 Enable the Locked option.

Director's View

Director's View lets you view your Bryce environment through the eyes of a director sitting outside the scene directing the action of all the objects—including the camera. The camera that generates the Director's View cannot be seen or positioned like an object. You have to use the positioning controls to move this view. As well, the motion of this view is not recorded as part of an animation.

When you're working on a still image, you can use Director's View to get a second perspective on your scene. You can also render your image from either camera.

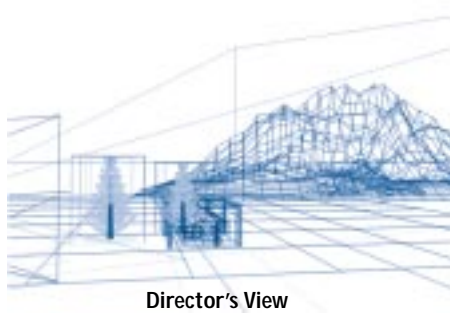
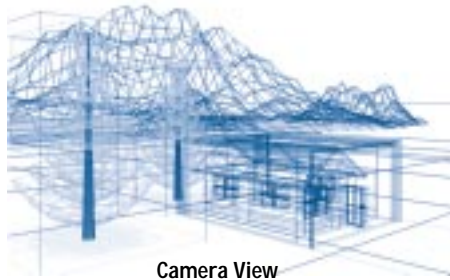

In a still image, you can use both the Director's View and the Camera View together to get different perspectives on your scene.

The real power of the Director's View becomes obvious when you're working on camera animations. Animating camera motions while in Camera View can be tricky at best and very unpredictable at worst. However, in Director's View you can see the camera as an object, which means that you can set up camera motion just like you would any other object.

To switch to Director's View:

- Click the triangle icon next to the View Control icon and choose Director's View from the menu.

Swapping Director's Views for Camera View

The Director's View and the Camera View are interchangeable. So you can move the Camera View to the position of the Director's View, or vice versa.

Even though you can't directly position the camera that produces the Director's View in the Working window, you can set up a Director's camera position by dragging the Camera to a position in the scene and then swapping the Camera position with the Director's View position.

To swap the Director's View position for the Camera View position:

- Click the triangle icon next to the Camera controls and choose either Camera->Director or Director->Camera from the menu.

Orthogonal Views

There are six other views available through the View controls, but these views are not generated by any camera. The other views (Top, Bottom, Left, Right, Back and Front) are perspective-free views of your scene called

orthogonal projections. When you're using one of these views you cannot use the Camera controls.

Refer to "Orthogonality and Views" on page 25 for more on orthogonal views.

The orthogonal views are another way of seeing the camera as an object in the scene. This can be invaluable when you're animating the camera, or setting up a complex scene.



Using the orthogonal views, you can quickly move to different views of your scene. These views also let you see the camera as an object.

If you hit the Render button while in an orthogonal view, Bryce moves the camera to the position you need, and renders your image. Refer to "Rendering" on page 403 for more on rendering.

Positioning the View of Your Scene

When you position a view, you're affecting the position and orientation of a camera, not the scene. The scale and position of objects remains constant; only your view of the scene changes.

The controls described in this section can be used to position either the Camera View or the Director's View. However, some controls, like the Trackball, are limited when you're in Camera View.

The controls behave differently depending on the Camera Mode you select.

Bryce has two sets of controls for positioning your view of the scene: the Trackball and the Camera controls.

The Trackball lets you adjust the position of the camera, as well as its orientation.

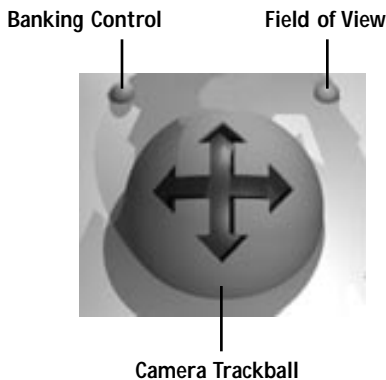

The Trackball lets you adjust the position and orientation of the camera.

The Camera controls change the position of the camera along the X, Y and Z axes.

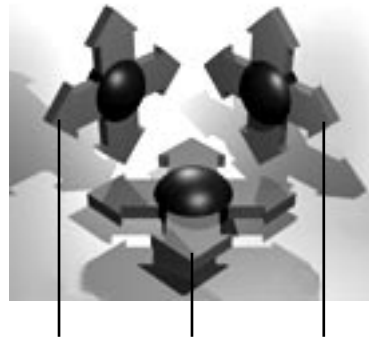

Y-Z Control X-Z Control X-Y Control

The Camera controls let you adjust the position of the camera in the X, Y and Z axis.

Camera Modes

The cameras in Bryce have four modes that affect the behavior of all the positioning controls. Three of the modes are only available when you're in Director's View. The only mode available in Camera View is Free.

Trackball Mode

In this mode the camera orbits around your scene. The center of the orbit, or origin, is the center point of a box which encompasses all the objects in your scene.



In Trackball mode the camera orbits around the center point of a box that surrounds all the objects in your scene.

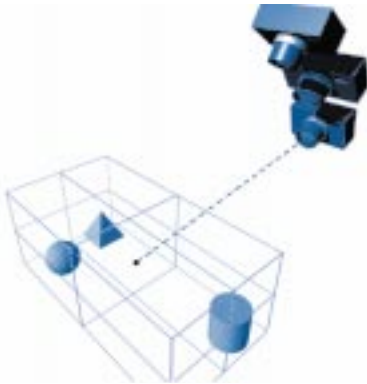

When the size of your scene changes, so does the center of rotation of the camera.

As the size of your scene changes, so does the size of the box, which changes the box's center point. As a result, the center of rotation for the camera also changes as you change the size of your scene. In fact, in this mode the camera's center of rotation is constantly updated so that it always remains in the center of the scene.

Center to Selection Mode

In this mode the camera also orbits around the scene. The center of the orbit, in this mode, is a selected object. The selected object becomes the pivot point for the camera. As the object moves so does the camera's center of rotation. This mode is the best way of making sure that specific objects always remain in view.

Tripod Mode

In this mode the center of rotation is fixed at the center of the camera, so it actually pivots in place. As its name suggests, the camera acts like it's on a tripod. It can rotate around, or tilt up and down, but it always remains in place.

Use the Tripod mode in conjunction with the Eye Level Camera command to get a sense of height. Refer to "Camera Control Options" on page 336 for more on this command.

Free Mode

In this mode the camera is completely unconstrained. Its center of rotation can exist anywhere, from its center to a point somewhere in the scene. Since the placement of the camera's center of rotation is not limited, this mode can simulate any of the other modes. For example, if you place the camera's origin point in its center, it acts like its on a tripod.



In Free mode the camera can move to any point and can rotate around its center or any other point in the scene.

Refer to “Manually Positioning the Camera” on page 339 for more on positioning the camera’s origin point.

To choose a camera mode:

- 1 Double-click either the Trackball or one of the Camera controls. The Camera & 2D Projection dialog appears.
- 2 Make sure the General tab is visible.
- 3 Click one of the mode buttons at the top of the dialog.

You can also switch between modes by clicking the triangle icon next to the Trackball and choosing a mode from the menu.

Using the Trackball

The Trackball lets you rotate the camera around its origin point. The position of the origin depends on the Camera mode you select. Refer to previous sections for more on these modes.

The Trackball doesn’t rotate the scene, it only changes the camera’s location (Offset) and orientation (Rotation) relative to your scene.

To move the camera using the Camera Trackball:

- Drag the mouse over the Camera Trackball control. The view of your scene moves in the direction you drag.

Using the Camera Controls

Camera controls let you move the view of your scene along specific axes. When you’re using these controls, the view does not tilt or rotate from its original position. It only moves up, down, back or forward.

Camera controls are not available if you are in any Orthogonal View. When unavailable, these controls turn white. If you are in an Orthogonal View, you must use the Zoom and Pan tools for navigation. Refer to “Orthogonality and Views” on page 25 for more on these views.

The Camera controls behave differently depending on Camera Mode selected:

- In Trackball and Center to Selection modes the Camera controls change the position of the camera, but the origin point remains the same. So in this mode the controls are actually adjusting the radius of the camera’s orbit.
- In Tripod mode the controls change both the position of the camera and the origin point.
- In Free mode, the controls change position of the camera and its origin point at the same time. In this mode the relative positions of the camera and the origin point remain the same. So, if the camera’s origin point is offset, it will remain offset when you use the Camera controls.

If you hold down Option/Alt while in this mode, the origin point will remain fixed.

There are three Camera controls available:

X-Y Camera Control

The X-Y Camera control provides control for horizontal and vertical motion. The sphere at the center of the camera control lets you move the camera in both the X and Y axis. The arrows let you constrain movement either horizontally or vertically.

This control affects your camera's position (Offset) only, not its orientation (Rotation).

X-Z Camera Control

The X-Z Camera control provides control for horizontal and depth motion. The sphere at the center of the camera control lets you move the camera in both the X and Z axis.

This control affects your camera's position (Offset) only, not its orientation (Rotation).

Y-Z Camera Control

The Y-Z Camera control provides control for vertical and depth motion. The sphere at the center of the camera control lets you move the camera in both the Y and Z axis.

This control affects your camera's position (Offset) only, not its orientation (Rotation).



Use these controls to move the camera along the Y axis.



Use these controls to move the camera along the X axis

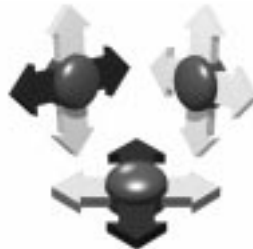

Use these controls to move the camera along the Z axis

To move the camera in two axes at once:

- Drag the sphere at the center of one of the Camera controls. The cursor becomes a four-way arrow.

The motion of your mouse determines the direction of the camera movement:

X-Y Camera control: moving up, down, left and to the right, moves the camera up, down, left and to the right.

X-Z Camera control: moving up, down, left and right moves the camera forward, backward, left and to the right.

Y-Z Camera control: moving up, down, left and right, moves the camera up, down, forward, and backward.

To move the camera along a single axis:

- Drag along the tip of an arrow.

When you move the cursor over an arrow point, it changes to a letter to identify the axis of constraint.



When you pass over a the tip of an arrow, the cursor changes to a letter to identify the axis of constraint.

Camera Control Options

The Camera controls have options that lets you move the camera to create specific views.

To use a Camera control option:

- Click the triangle icon next to the Camera controls and choose an option from the menu:



Click the triangle icon next to the Camera controls to display the options menu.

Center Scene rotates the camera so that all items in your scene are centered in the Working window. This option only affects the camera's rotation, not its offset. If you can't see all the objects in your scene after using this option, try pulling your camera back a bit with one of the Z controls.

Center Selection rotates your camera such that any selected object or objects will be centered in your view. This option does not reposition the object itself, only the camera's rotation relative to the selected object.

Eye Level Camera repositions the camera to just above ground level. Use this command (especially in conjunction with the Trackball's Tripod mode) to create the feeling of large, looming mountains or other objects. This is also effective in concert with the Field of View control.

Choose **Camera>>Director** or **Director>>Camera** to select either the Director or Camera View.

Edit Current Camera brings up a dialog box that allows you to enter current camera information. "Positioning the Camera Numerically" on page 338

Banking Controls

The Banking control sphere tilts your Camera (really rotating the camera on the Z axis), creating the effect of a tilted horizon. This control is great for creating tilted airplane cockpit views. Banking simulates a Roll action.

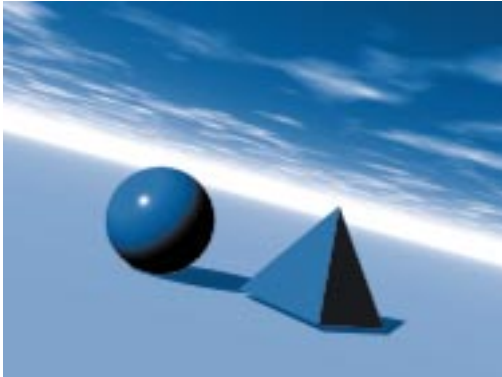

This scene was created by banking the camera.

To bank the camera:

- Drag the Bank control. Drag right to bank to the right and left to bank to the left.
Press Option/Alt-click in this control to reset to normal. The normal, or default, setting is zero.

Field of View

The Field of View control sphere acts like a wide-angle lens control. The higher the setting, the wider the field of view for your lens.

Because you are admitting more information into your lens, it will create the illusion that objects are receding from view, or getting smaller. That is not the case. Since you're

admitting more information, existing objects necessarily occupy a smaller percentage of space within your field of view.

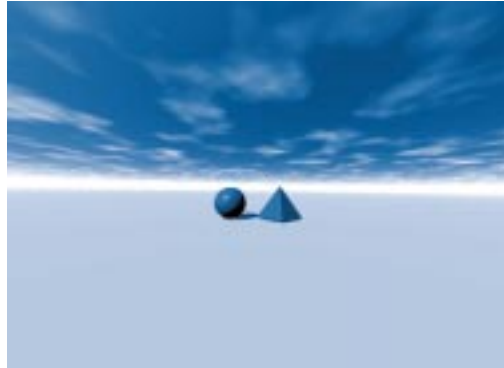

This scene was created by increasing the camera's field of view.

If you drag the Camera Z control to bring your "receding" objects back up to a larger area in your view, perspective distortion effects appear. This is particularly effective for creating broad, swooping cloud scenes.

When you view the camera in Director's View or one of the orthogonal views, you'll be able to see the camera's Field of View displayed as a 3D pyramid that extends out from the camera wireframe.



The large triangle that extends out from the camera's wireframe represents its field of view. As the field of view changes so does the shape of the triangle.

To increase/decrease the camera's field of view:

- Drag the Field of View control. Drag right to increase the field of view and left to decrease it.
Option/Alt-click on this control to reset to normal. The normal, or default, setting is 60°.

Positioning the Camera Numerically

The most precise way of positioning the view of your scene is by using the Camera & 2D Projection dialog. This dialog lets you enter values to set the camera position, the position of the camera's origin point, rotation and field of view. The dialog can be used to adjust either the Camera View or the Director's View.

When you display the dialog, you can see the numerical position of the camera and the position of its origin point. You can also see the currently active Camera Mode.

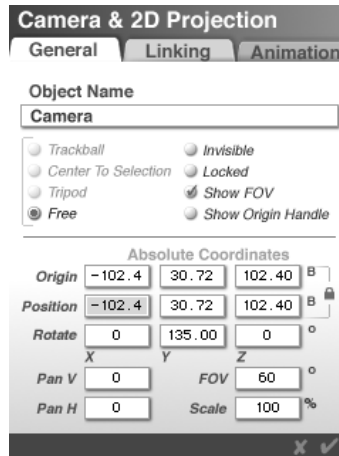

The Camera & 2D Projection dialog lets you view and set position, camera mode and origin point position options for the current camera.

The dialog uses either Absolute or Relative coordinates for positioning values.

There are different options available in the dialog depending on whether you're in Camera View or Director's View. When you're in Camera View, the only Camera Mode available is Free. As well, the Origin fields are only available if you're using Free Mode.

Since the camera is an object, there are several more controls available when you're in Camera View. These controls let you set linking and animation options. Refer to "Setting Camera Object Properties" on page 329 for more.

To position the camera's origin point numerically:

- 1 Double-click either the Trackball or one of the Camera controls. The Camera & 2D Projection dialog appears.
- 2 With the Camera View active, make sure the General tab is visible.

- 3 Click the Free Mode button.
- 4 Enter values in the Origin X, Y and Z fields.

To set the position of the camera numerically:

- 1 Double-click either the Trackball or one of the Camera controls. The Camera & 2D Projection dialog appears.
- 2 With the Camera View active, make sure the General tab is visible.
- 3 Enter values in the Position X, Y and Z fields.

You can enter negative values here. Technically, since the Bryce environment is infinite, the range is infinite as well, but higher values can create unpredictable results. The default values are 102.40, 30.72, and 102.40.

To rotate the camera numerically:

- 1 Double-click either the Trackball or one of the Camera controls. The Camera & 2D Projection dialog appears.
- 2 With the Camera View active, make sure the General tab is visible.
- 3 Enter values in the Rotate X, Y and Z fields. Values are expressed in degrees.

X, Y and Z rotations are also known as Yaw, Pitch and Roll. The Z rotation, or Roll, field, describes the current value for the Banking control.

You can enter negative values in these fields. The effective range is +/- 999. Default values are 0, 135, and 0°.

To set the Field of View numerically:

- 1 Double-click either the Trackball or one of the Camera controls. The Camera & 2D Projection dialog appears.
- 2 With the Camera View active, make sure the General tab is visible.
- 3 Enter a value in the Field of View field.

The value in this field, expressed in degrees, describes current settings for the Field of View control. The effective range is 1 to 180°, and the default value is 60°.

Manually Positioning the Camera

You can manually position the camera by adjusting the position of the camera wireframe in the Working window. The camera wireframe is only visible when you're in Director's View or one of the orthogonal views.

In the Director's View, top, right, front, left, back and bottom views (also known as orthogonal), you will see a blue Camera wireframe, which represents the location of

your Camera. You can then drag the Camera wireframe to change Camera position. The Nano-Preview updates to reflect your changes.

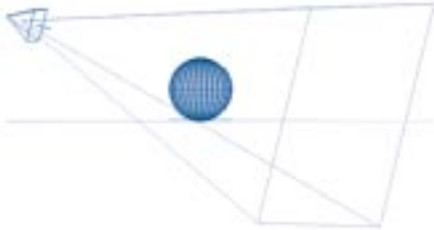

The camera indicator only appears in either the orthogonal views or the Director's View. Drag the indicator to adjust the camera's position.

Camera Origin Point

In its default state, the Camera's origin point is not visible and is located at its center.

When the Camera's origin point is visible, it appears as a green dot in the center of camera's wireframe.

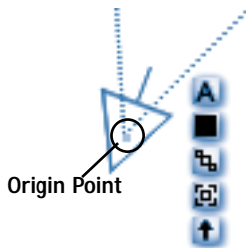

The green dot in the center of the camera wireframe represents its origin point.

You can simulate any of the camera modes by dragging the camera's origin point to different locations in the scene:

- If you position the origin point in the center of the scene, the camera acts like it's in Trackball mode. When you rotate the camera, it moves around the position of the origin point.

- If you position the origin point over an object in the scene, it acts like it's in Center to Selection. When you rotate the camera object, it will pivot around the object under the origin point.
- If you leave the origin point positioned at the center of the camera object, it acts like it's in Tripod mode.

Once you offset the origin point, all the camera's movements will be altered, so when you switch to Camera View, the camera may not move as expected.

To display the camera's origin point:

- 1 Switch to one of the orthogonal views or Director's View.
- 2 Click the camera wireframe.
- 3 Click the A icon that appears next to the camera's wireframe. The Camera & 2D Projection dialog appears.
- 4 Click the General tab and enable the Show Origin Handle option.

To position the camera manually:

- 1 Switch to Director's View or an orthogonal view.
- 2 Drag the camera wireframe to a location in the scene.
or
 - Click the camera wireframe and use the tools in the Edit palette to move, or rotate it.

To position the camera's origin manually:

- 1 In the Camera & 2D Projection dialog, display the camera's origin point.

- 2 Drag the green point to a location in the scene.
 - Hold down Shift and click the origin point to reset it to the center of the camera object.

Aiming the Camera

The only problem with positioning the Camera using the Orthogonal, or Director's Views is that the view from the Camera remains fixed as you adjust its location, so you may inadvertently lose the objects you were looking at when the position of the Camera changes.

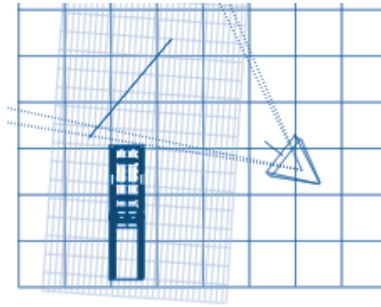
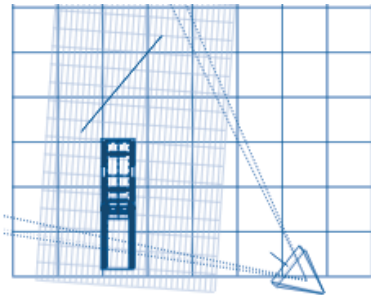

When you move the Camera, it's still pointing in the same direction but from its new position, only one of the objects in the scene is visible.

To solve this problem, Bryce lets you adjust the aim of the camera as you adjust its position.

When you look at the Camera as an object, you'll see that there is a control handle extending out from the front of the object. This



For example, at the beginning of this animation the Camera is pointing at the object in the center of the scene. The view from the Camera shows all the main objects in the scene.

handle represents the Camera's current aim. By dragging this handle to a point in your scene, you can change the Camera's aim.



The handle that extends out from the front of the Camera, lets you aim the camera.

When you change the aim of the Camera, it rotates to face the new target, but remains in the same position.

To change the Camera's aim in an orthogonal view:

- 1 In the Working window, click the triangle icon next to the View Control and choose top, left, right, bottom, front or back from the menu.
- 2 Drag the end of the control handle to the point in you scene where you want the camera to aim.

As you drag, the end of the handle changes to a red dot so you can see the aiming point better.

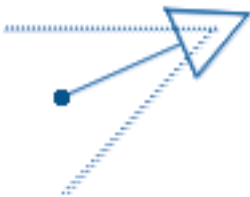

As you drag the end of the camera's control handle, it changes to a red dot. The dot represents the point where the camera will aim.

Saving Camera Positions

You can save your favorite camera positions using the Memory dots. The dots let you store up to seven different views of your scene

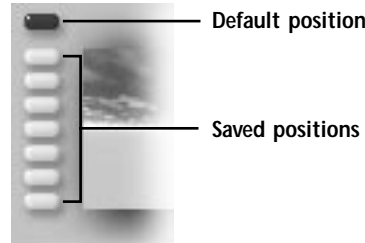

Memory dots let you save views of your scene for later use.

The uppermost dot, slightly separated from the rest, is a quick way to return to the default Bryce camera position. There is no way to clear this dot. It will always contain the default Camera settings.

Dot settings are saved with your scene file, so if you open a previously saved scene, your dot settings from the previous session remain in place.

When you click on a full dot to activate it, the saved position becomes the current Camera View. If you switch to an active dot, and then want to return to your previous Camera View, undo the operation.

To return to the default camera position:

- Click the top memory dot.

The view returns to the default, regardless of how many changes you've made.

To save a camera position to a memory dot:

- Click an empty dot. Empty dots appear gray. Full dots appear turquoise.

To switch between saved positions:

- Click a full (turquoise) dot.
Active dots appear turquoise with a white dot in the middle.

To clear a full dot:

- Option/Alt-click a full dot. The dot turns gray.

To switch between positions using the keyboard:

1 Press the numbers indicated to activate the saved memory dots. Press 1 through 4 for different camera views.

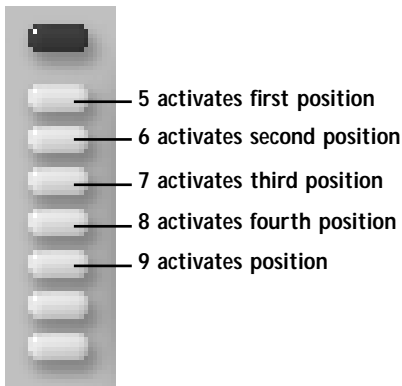

There are no keyboard shortcuts for the remaining two dots.

Setting Up Lights

There are two types of lights in Bryce—natural and direct. Natural lighting is provided by the Sun. By default every scene contains a sun. Direct light is provided by light sources.

The light from direct light sources can be used to either add hyperrealism to natural scenes, or add light to objects that cast light in the scene, like lamps. The lighting setup you choose can greatly affect the look of your scene, so experiment with various lighting setups.

Creating Direct Light Sources

There are five types of direct lights you can create: Radial, Spot, Square Spot, Parallel and Cylindrical Parallel

You can create as many light sources as you need. The only limit is your system's memory. Creating additional lights (or light sources) may add significantly to the render time of your scene.

The size, position, and orientation of a light source can be edited exactly like any other object. Refer to "Transforming Objects" on page 285 for more on transforming objects.

You can also link lights to specific objects so that a light source moves as the object moves, or you set a light to track an object. When it's tracking an object, the light reorients itself so

that it's always facing the object no matter where it moves. Linking and tracking are quick ways of animating light positions.



The motion of all the light sources in this example were animated using the track feature.

Light attributes can be edited in the Edit Lights dialog.

Radial Light

Radial Lights throw light equally in all directions. Use this as a general light source, and remember that you can make these lights as tiny as you like, as many as you need.



The lighting in this scene was created using a Radial Light.

Spotlight

Spotlights throw light along a cone-shaped path, creating the classic “stage spot” effect.



The lighting in this scene was created using a Spotlight.

Square Spotlight

Square Spotlights are the same as spotlights, except they cast light along a pyramid-shaped path, creating a square spot where the light falls.



The lighting in this scene was created using a Square Spotlight.

Parallel Light

Parallel Lights cast parallel rays, resulting in no spatial distortion of shadows. This type of light is very useful for creating specific shadow patterns, or when used with gels, for creating a slide projector.



The lighting in this scene was created using a Parallel Light.

Cylindrical Parallel Light

Cylindrical Parallel Lights work exactly like parallel lights except that they produce cylindrical tubes of light and cast circular spots where the light falls.



The lighting in this scene was created using a Cylindrical Parallel Light.

To create a light source:

- 1 Make sure the Create palette is visible. If it's not, click the Create button at the top of the Bryce window.

2 Click one of the create light tools:



Creates Radial lights



Creates Spotlights



Creates Square Spotlights



Creates Parallel lights



+ Ctrl
Creates Cylindrical
Parallel lights

Note that Cylindrical Parallel lights are the only lights that require a modifier (Ctrl) key.

Editing Light Attributes

You can edit the attributes of any light using the Edit Lights dialog. This dialog lets you control the color, intensity and sharpness of a light source.

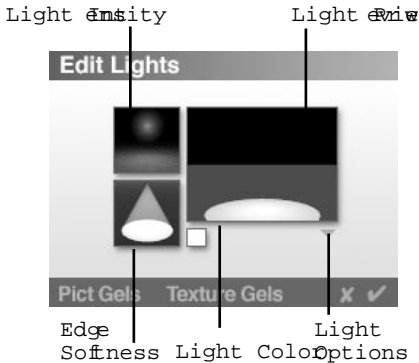

Use the Edit Lights dialog to adjust the brightness, color and hardness of a light.

To access the Edit Lights dialog:

- 1 Select a light. The Object Controls appear next to the light's bounding box.
- 2 Click the E button.

To adjust light intensity:

- In the Edit Lights dialog, drag the Light Intensity control.
Drag right to increase light intensity and left to decrease intensity.

To set a light's color:

- In the Edit Lights dialog, click the Light Color control and choose a color from the picker.

To disable shadow casting for a light source:

- In the Edit Lights dialog, click the triangle icon at the bottom right corner of the preview area, and choose Disable Cast Shadows option.
The light from this source can illuminate the surface of an object, but does not create shadows.

Light Preview

The Light Preview area displays the effects of your changes to the intensity and edge softness of a light.

You can have this preview display the light against a neutral background, or show the light in the scene.

To set the preview options:

- In the Edit Lights dialog, click the triangle icon at the bottom right corner of the preview area, and choose a preview option:
Render in Scene displays your scene in the Preview area. This lets you see how the changes you make to the selected light will impact your entire scene.
Render Against Neutral displays the light against a flat background. This lets you isolate the light so you can clearly see subtle changes.

Light Attributes

The light editor lets you adjust three attributes which let you create more realistic-looking light sources:

- The light's spread
- Edge Softness
- Falloff

The spread of the spotlight (also called the Half Angle) controls the size of the light cone projected. The size of the light's wireframe determines the spread of the light. The bigger the wireframe, the larger the spread.

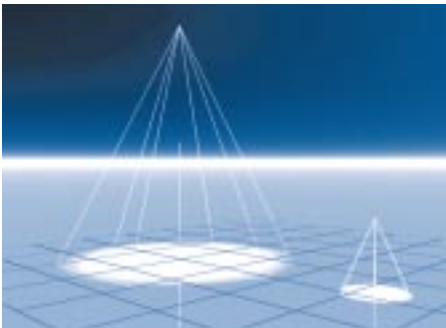

The size of a light's wireframe controls the light's spread.

To adjust the spread of a spotlight:

- 1 Select a spotlight.
- 2 Drag the one of its bounding box control points to set the wireframe's size.
Increase the size to increase the spread and decrease its size to decrease the spread.

The Edge Softness attribute lets you set the sharpness/softness of the edges of the spot projected by the light.

To adjust a light's edge softness:

- In the Edit Lights dialog, change the position of the Edge Softness control.
Drag left to sharpen the edges and right to soften the edges.

Light Falloff

Light falloff lets you control the relationship between the intensity of a light and the distance from the light. In the real world, the farther you are from a light source, the less influence it has on the illumination of your surrounding. In other words, the greater the distance, the weaker the light.

In Bryce there are four types of falloff you can apply to a light:

- Linear Falloff causes the light's intensity to fall off at a constant rate. When you use this type of falloff the light's range is rather large. This type of falloff is good for outdoor lights like searchlights.
- Squared Falloff causes the light's intensity to fall off rapidly. When you use this type of falloff, the light's range is quite limited. This is useful for indoor lights, like lamps.
- Ranged Falloff causes the light to change abruptly from full intensity to zero (no

illumination) after a defined distance range.

- No Falloff causes the intensity of the light to stay the same regardless of the distance.

To adjust a light's falloff:

- 1 In the Edit Lights dialog, click the triangle icon at the bottom of the dialog and choose either Linear Falloff, Ranged Falloff, Squared Falloff, or No Falloff from the menu.
- 2 A dialog box appears into which you enter a distance or range if appropriate for the type of falloff you selected.

Creating Visible Lights

Visible lights make your light source visible in the scene, like the ball of light that appears around a lamppost on a foggy night.

There are two types of visible lights:

- Surface Visible Lights
- Volume Visible Lights

When you create a surface visible light, the light from the object appears as a semi-transparent shape extending out from the light source.

Surface Visible lights have the same attributes as a non-visible light, so you can use the Edge Softness control to make the shape that extends from the light fuzzier at the edges, to give it a more realistic feel, or the Falloff options to adjust the range the light.

The properties within the light are controlled by the default Surface Material applied to the light object. The material can be edited in the

Materials Lab. By changing the material, you can change the color of the light, the intensity of the light's color and many other properties.



When you create a surface visible light source, it appears as a semitransparent object in the scene.

When you create a Volume Visible light source, a preset Light-sensitive Volume Material is applied to the light source. This makes the light coming from the light source appear visible in the scene, so in the case of a spotlight, the light would appear as cone. The light also becomes volumetric and reacts to other lights around it. Objects within the cone interact with the light. They can block it, reflect it, etc. Any textures applied to the light also have volume.

The material applied to the object is pre-defined for you, but you can edit its properties in the Materials Lab. By editing the material you can change the light's intensity, color and transparency.



When you create a volume visible light source, the light emanating from the light source is visible in the scene. This light has volume and interacts with the object inside it.

The real difference between the two types of lights becomes apparent when you apply a gel to the light. In Surface Visible lights, the gel texture is wrapped around the light cone like a skin. Making it semitransparent makes it look more real, but it doesn't make it interact with objects inside the cone.

On the other hand, volume visible lights create a real illuminated volume. The texture gel exists everywhere inside the cone, and the objects within the cone are directly affected by the texture. The light also interacts with the surrounding light sources.



In this example, the same objects were illuminated by first a surface visible light...

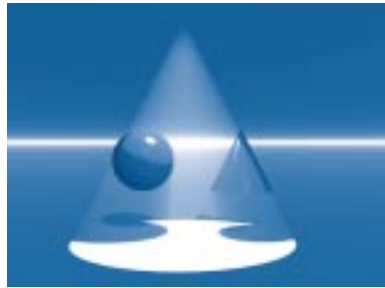

...and then a volume visible light.

It's a good idea to choose to apply the Infinite Light option to both types of visible lights, as this option extends the light's range. This gives the light a more realistic look.

To create a surface visible light:

- 1 Create a light source.
- 2 Select the light in the Working window.
- 3 Click the E button that appears next to the light's bounding box. The Edit Lights dialog appears.
- 4 Click the triangle icon below the light preview and choose Surface Visible Light from the menu.

A number of preset Surface material properties are applied to the light.

- Click the triangle again and choose Infinite light from the menu if you want to extend the light's range.

To create a volume visible light:

- 1 Create a light source.
- 2 Select the light in the Working window.
- 3 Click the E button that appear next to the light's bounding box. The Edit Lights dialog appears.

- 4 Click the triangle icon below the light preview and choose Volume Visible Light from the menu.

A number of default Volume material settings are applied to the light source.

- Click the triangle again and choose Infinite light from the menu if you want to extend the light's range.

Editing Visible Light Materials

The materials applied to a visible light control many of its properties. Although these materials can be edited, just like any other object's material, you should keep in mind that when you're editing a light's material in the Materials Lab, you're changing how the light source will appear in the scene.

Any texture components you apply to the light's material will appear as gels.

For Surface Visible lights, the light's material is a Surface material. For a Volume Visible light the material is a Volume Material.

Refer to "Surface Material Channels" on page 196 for more on editing Surface materials, and "Volume Material Channels" on page 206 for more on editing Volume materials.

Applying Gels

Gels are filters which are placed directly in front of lights to change the colors cast by the light, or to cast specific kinds of shadows.

In Bryce, you can use any picture or procedural texture as a gel. Once you've assigned a gel to a light source, you'll be able to see the pattern of the gel on any object it shines on. For example, if you apply a picture to a Square Spotlight, you

can create a slide projector, or you can throw a wild texture across your entire scene by assigning a Texture gel to a Radial Light.



This lighting effect was created using a gel.

When you apply a gel to a visible light, the texture's pattern is visible throughout the visible light.

To use a picture as a gel:

- 1 In the Edit light dialog, click on the Pict Gels text button at the bottom of the dialog. The Pictures dialog appears.
- 2 Choose a picture from the preset library, or click the Load button and load a picture. Refer to "Working with Pictures" on page 108 for more on the Picture dialog.
- 3 Click the checkmark. The picture is applied as a gel.

To use a texture as a gel:

- 1 In the Edit Light dialog, click on the Texture Gels text button at the bottom of the dialog. The Preset Materials Library appears.
- 2 Select a material from one of the categories available.

Refer to “Using the Preset Materials Library” on page 232 for more on the Preset Materials Library.

- 3 Click the checkmark. The texture in the material is applied as a gel.

To use a texture as a Gel, you must select a preset that contains a texture. Preset materials that contain only color or optic information (such as many found in the Simple & Fast category) will have no effect.

If you selected a color other than white in the Edit Light dialog, that color overrides colors from Texture gels. However, the luminance patterns are still used.

Positioning Lights

Light wireframes can be edited exactly like any other object, either directly in the scene using its bounding box, or indirectly using the tools in the Edit palette.

Refer to “Positioning Objects” on page 294 for more on positioning objects.

Linking and Tracking with Lights

Since lights act just like other objects, you can link them to other objects, or have them track other objects in the scene.

In an animation, lights that track an object can create some very complex lighting effects.

Refer to “Linking Objects” on page 305 for more on linking, and “Tracking Objects” on page 382 for more on Tracking.



14

Animating

Key Event Animation and Bryce

Animation is process of simulating time. In the real world, we perceive time through the changes in our environment. The most obvious type of change is motion. When an object changes position at different points in time, it appears to be moving. But, an object doesn't have to be moving to indicate the passage time. A change in color, texture or geometry also indicates that time is passing. These changes in the environment are called *key events*.

You create an animation, in Bryce, by moving to different points in time and changing the properties of a scene to define the action at

that point in time. Bryce automatically fills in the gaps between these key events to create the illusion of time passing.



Animation can simulate the passage of time by changing the position of an object at different points in time. Here an airplane is at the top of the scene at one point in time...

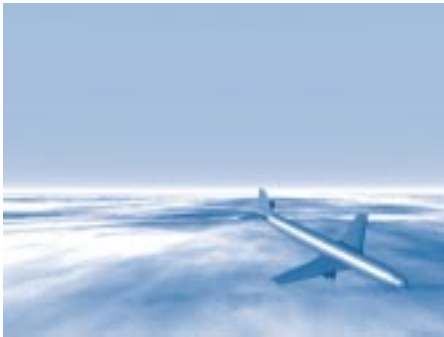

...and at the bottom of the scene at another point...



...by filling in the gaps between the two points, or key events, Bryce simulates motion.

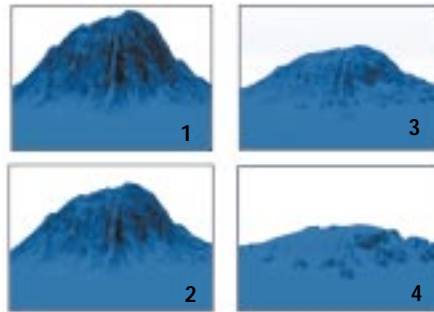

The same principle applies to other scene properties. Here, the illusion of time is created by changing the geometry of a terrain object at two different points in the animation.

You can use key event animation to animate most of the properties in your scene:

- The motion of object, lights and the camera.
- Object size, shape and orientation.
- Camera and light parameters.
- Object Material properties.
- Terrain object geometry.
- Environment properties.

Previewing Your Animation

Any time you make a change to your animation, you can see it immediately in the nano-preview window as a movie, or preview it in the working window. See “Previewing Animations” on page 363.

Time-Based Animation

In Bryce, key events are tied to real-world time increments (minutes and seconds) rather than individual animation frames. This means that you can create key events at specific points in time without worrying about the number of frames in your final animation.

Bryce automatically creates all the frames necessary to move from one key event to another. If you change the frame rate, Bryce adjusts the number of the frames between key events to match the new frame rate.

For example, let's say your frame rate is set to 15 fps (frames per second) and then you set up two key events, one at 1 second and the other at 2 seconds. Bryce automatically fills in the 15 frames necessary to move from the key event at 1 second to the key event at 2 seconds. If you change the frame rate to 30 fps, Bryce will add another 15 frames between the two key events to match the new frame rate.

Animation and Motion Paths

As you change the position, of an object, Bryce creates a motion path which shows you the path the object will take as it moves from one key event to another.

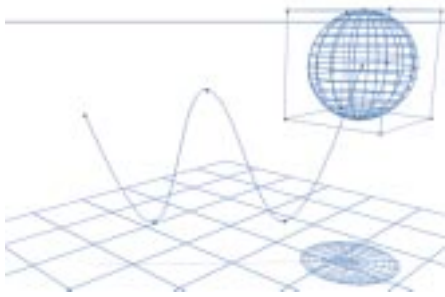

An object's motion path shows you the trajectory of the object as it moves from one key event to another.

You can edit an object's motion path to adjust its trajectory throughout the course of the animation.

Refer to "Editing Motion Paths" on page 378 for more on motion paths.

Animatable Properties

Each characteristic of an object or effect that can be animated is called a property. Most objects have many animatable properties. Properties like position, size and orientation are common to all objects. Other properties are specific to certain types of objects.

Lights have special properties like brightness, falloff and gels.

Skies have their own set of properties that control everything from cloud coverage to the time of day.

The properties of individual objects can change depending on the material you apply. The color, texture, and density of an object can also be animated.

Some properties can be animated directly in a specific editor. Object material properties can be animated from within the Materials Lab and terrain geometries can be edited from within the Terrain Editor.

Properties in the Sequencer

Every time you change an object's property, it appears as a key event in the animation's Sequencer. In the Sequencer, each property of an object can be viewed on a separate timeline. You can expand an object's listing to see all the transformations or changes that have been applied to its properties. If you have not performed any transformations on the object, it cannot be expanded.

Refer to “Editing Property Timelines in the Sequencer” on page 368 for a complete discussion of the Sequencer.

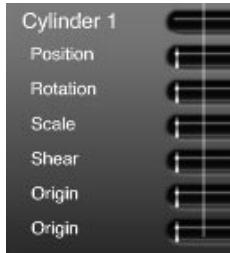

You can expand an object’s listing to see the timelines for the transformation applied to it.

To expand a listing in the Sequencer:

- 1 Make sure the Advanced Motion Lab is visible. If it’s not, choose **Objects menu> Advanced Motion Lab**.
- 2 Click the object’s listing.

Creating Animations

The Animation controls are the tools you’ll use most often when creating animations. The palette provides tools for most of the basic animation functions:

- viewing the timeline
- moving the current time
- setting the length of the animation
- specifying the Working Area
- previewing the animation
- recording key events
- adding/deleting key frames

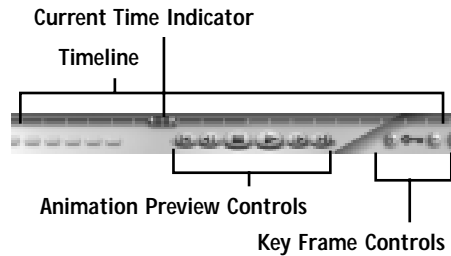

The Animation controls let you move through the timeline of your animation and create key frames.

The Animation controls appear at the bottom of the Working window as well as in the Terrain Editor and the Materials Lab.



Besides the Working window, the Animation controls also appear at the bottom of the Terrain Editor...



...and at the bottom of the Materials Lab.

The Animation controls are made up of three areas:

The Timeline, located at the top of the palette, displays a visual representation of the time in your animation. The indicator on the timeline (called the *Current Time Indicator*) represents the current time.

The Animation Preview Controls, located below the Timeline, let you preview your animation in the Working window.

The Key Frame Controls, located at the right edge of the palette, let you add and delete key frames.

To display the Animation controls in the Working window:

- By default the Animation controls are located at the bottom of the Working window. If the Selection palette appears the bottom of the window, click the Time/Selection Palette toggle in the bottom-right corner of the Bryce window (or press S).



Use the Time/Selection Palette toggle to switch between the Animation controls and the Selection palette.

The button switches between the Selection palette and the Animation controls.

Setting Up an Animation

Before you start setting up key frames or adjusting the timeline, you should set up some general parameters for your animation.

The Animation Setup dialog lets you set up the duration, the frame rate and whether you want to display animation time as SMPTE (i.e.; hours:minutes:seconds:frames) or Frame numbers.

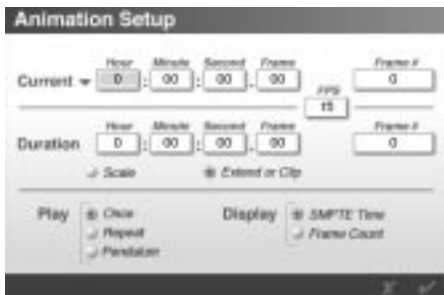

The Animation Setup dialog can be used to set the duration of your animation or to move to a specific point in the timeline.

To set the duration of your animation numerically:

- 1 Choose **File menu > Animation Setup** or double-click the Current Time Indicator. The Animation Setup dialog appears.
- 2 Click the Scale Timeline button. This switches the Duration fields to set the duration of your animation.
- 3 In the Duration fields, enter the total length of your animation in hours, minutes, seconds and frames.

When you enter a duration, Bryce automatically calculates the number of frames in the animation, based on the current frame rate. The number of frames is displayed in the Frame # field.

Setting the Frame Rate

The Frame rate for your animation can have a large impact on the final quality of your rendered movie. A low frame rate, is faster to render but may produce more jumpy-type motion, while a higher frame rate produces much smoother motion.

Bryce displays frames as Frames per Second (fps). 15fps is usually good enough for motions displayed on a computer. 30fps is video quality.

To set the frame rate for your animation:

- 1 Choose **File menu > Animation Setup** or double-click the Current Time Indicator. The Animation Setup dialog appears.
- 2 Enter a frame rate in the FPS field.

Working with the Timeline

The Timeline for your animation shows you:

- A graphical representation of time.
- The total length of the your animation within that time.
- The current time.
- The Working Area.

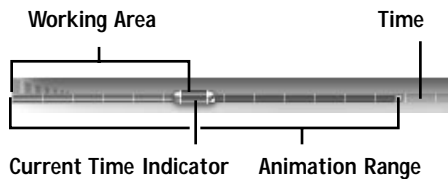

Current Time Indicator **Animation Range**

The timeline represents time in your animation. It can be used to set the length of the animation and to move the current time.

The Timeline appears in three places in Bryce: the Working window, the Terrain Editor and the Materials Lab.

All three timelines represent the same time. The only difference is that when you're in an editor, you can only add frames for properties associated with the editor. For example, in the Terrain Editor you can only add key frames associated with terrain properties.

Refer to "Animating Terrains" on page 396 for more on working with the timelines in Terrain Editor and "Animating Materials" on page 388 for more on working with the timeline in the Materials Lab.

When you preview a timeline in the Working window, you'll be able to see all the changes in your scene, including any changes you may have made in other editors or the Advanced Motion Lab.

Working with Time

The light gray area in the Timeline is called the Available Time Area and it represents all time. This area is unlimited, you can scroll the time area infinitely.

The white tick marks within the time are visual cues that let you know when the time area is moving. If you move the Current Time Indicator off the screen you'll see these white ticks move along the time area.



The light gray area in the timeline represents time. The white tick marks in the time area are visual cues to let you know when the area is being scrolled.

To scroll the time area:

- Drag the Current Time Indicator off the screen to the right.
You'll see the white tick marks move along the time area to the left.

Setting the Animation Range in the Timeline

The dark gray within the light gray area of the Timeline represents the total length of your animation. This area is usually hidden by the Working Area, so you may need to shorten the Working Area to adjust the Animation Range.

This area is automatically generated as you set up key events. The time of the final key event automatically creates the limit of the animation

range. However, you can manually extend or shorten the area to set the range of your animation.



The dark gray area of Timeline represents all the range of your animation.

You cannot shorten the Animation Range below the last frame in the scene since you can't have frames outside the animation range.

To manually set the Animation Range:

- In the timeline, drag the light green handle that appears at the end of the Animation range to the point where you want the animation to end.

The handle may be obscured by the Current Time Indicator, so you might have to move the indicator to a different position.

Setting the Current Time for an Animation

The large green handle in the Timeline is called the Current Time Indicator (commonly called a scrubber). It sets the current time of the animation.

The Current Time Indicator is the most important tool of the Animation controls. When you're creating key events, the Current Time Indicator controls when the key event occurs in the animation.

Refer to "Recording Key Events" on page 362 for complete instruction on creating key events.

As you move the Current Time Indicator the Text Display Area shows you the current time. If you're using SMPTE time, the current time is displayed as:

00:00:02.13
Hours Minutes Seconds Frame #

The Frame # changes as you change the frame rate for the animation. For example, at 15fps Bryce will insert 15 frames within each second.

If you're using Frame number, the number of the current frame is displayed.

You can also move to a specific point in time using the Animation Setup dialog. In this dialog, you can move to either a specific time or frame.

To move to a specific frame manually:

- Drag the Current Time Indicator along the Timeline.

As you drag, watch the Text Display Area. You'll notice that the final number cycles through each frame in the second of animation time. So at 15fps the final number will cycle through frame 0-14 between seconds.

Release the mouse button when the Frame # reaches the desired frame.

The Current Time Indicator also controls which portion of your animation is being displayed in the Working window.

When the indicator is at the beginning of the animation, you're seeing the first frame of the animation in the Working window. When you move the indicator, the Working window displays a different portion of the animation.

So, when you move the indicator to the center of your animation range, you're seeing what the animation looks like at the middle of the movie.

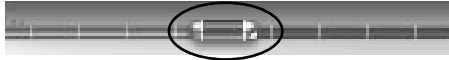

Use the Current Time Indicator to move the current time to different points along the timeline.

To move the current time manually:

- 1 Make sure the Animation controls are visible. If it's not, click the Time/Selection Palette toggle.
- 2 Drag the Current Time Indicator along the Timeline. Release the mouse button when the Text Display Area shows the desired time.

To move the current time numerically:

- 1 Choose **File menu > Animation Setup**. The Animation Setup dialog appears.
- 2 In the Current fields, enter the hour, minutes, seconds and frame you want to move to.

The Frame # field displays the number of the frame located at the specified time.

To save the position of the Current Time Indicator:

- 1 Make sure the Animation controls are visible. If it's not, click the Time/Selection Palette toggle.
- 2 Move the Current Time Indicator to the position you want to save.
- 3 Click on an empty Memory Dot at the bottom of the Animation controls.

A dot is empty when it appears gray.



Use the Memory Dots to save the position of the Current Time Indicator.

To move the Current Time Indicator to a saved position:

- 1 Make sure the Animation controls are visible. If it's not, click the Time/Selection Palette toggle.
- 2 Click the Memory dot for the position you want to use.

To delete a saved position:

- 1 Make sure the Animation controls are visible. If it's not, click the Time/Selection Palette toggle.
- 2 Option/Alt+click on a full memory dot. A full dot appears teal.

Setting Up the Working Area

The green portion of the Timeline represents the Working Area. This area highlights the portion of the timeline you're currently working on.



Use the Working Area to isolate the portion of the timeline you're currently working on.

When you're previewing your animation, only the portion of the timeline within the Working Area is previewed.

The Working Area is most useful when you're working on a long animations as it saves on preview time, or when you're refining a specific portion of your animation.

When you're rendering the animation, you can choose to render the entire animation, or just the Working Area portion.

You can also use the Working Area to render out sections of the timeline while your setting up the animation, and then render the entire Animation Range when you're creating the final animation.

To set the range of the Working Area manually:

- 1 Make sure the Animation controls are visible. If it's not, click the Time/Selection Palette toggle.
- 2 Drag either end of the existing Working Area. Release the mouse button when the Working Area is the desired length.

The Working Area cannot be extended past the end of the Animation Range.

To set the range of the Working Area numerically:

- 1 Choose **File menu**> **Animation Setup** or double-click the Current Time Indicator. The Animation Setup dialog appears.
- 2 Click the word "Current" at the top of the dialog and choose Working Range Low from the menu.
- 3 Enter the starting time for the Working Range.
- 4 Click the word again and choose Working Range High.
- 5 Enter the ending time for the Working Range.

Setting Timeline Scale

The scale indicator at the right edge of the timeline let you adjust the scale the timeline.

If you have a very long timeline, you can use this controls to scale it down so you can see the whole timeline at once. If you have a very short timeline, you can use the control to scale it up so it extends across the length of the palette.



Use the scale indicator to scale the timeline.

To set the scale of the timeline:

- 1 Make sure the Animation controls are visible. If it's not, click the Time/Selection Palette toggle.
- 2 Drag the scale indicator.
Drag right to increase the scale and left to decrease it.

The scale of the timeline does not affect its length, only how its displayed in the Animation controls.

Scaling Animation Duration

You can adjust the length of your animation, by scaling its duration to fit within a certain amount of time. For example, you created an animation that's 5 seconds long, but only want it to take up 3 seconds, you can scale the entire animation to last only three seconds.

When you scale the animation, all the events in the animation are compressed or stretched to fit within the desired amount of time. If you increase the scale, the events are stretched out,

so they take longer to complete. If you decrease the scale, the events are compressed to the action speeds up.

To set the scale of the entire animation manually:

- 1 Make sure the Animation controls are visible. If not, click the Time/Selection Palette toggle.
- 2 Hold down Option/Alt and drag the animation range handle. Release the mouse button when the duration of the animation is the desired length.



Option/Alt-drag the animation range handle to scale the animation down or up.

To scale the animation numerically:

- 1 Choose **File menu > Animation Setup** or double-click the Current Time Indicator. The Animation Setup dialog appears.
- 2 Click the Scale Animation button.
- 3 Enter the desired animation duration in the Duration fields.

Recording Key Events

You can record key events by enabling Auto-Record mode. The Timeline options menu, located at the right edge of the controls, lets you enable or disable Bryce's automatic animation system.



Use the Timeline options menu lets you to enable or disable animation.

When you enable Auto-Record mode every object transformation, or change of property you perform is recorded as a key event.

A key event can store any change in size, position, orientation, material property, sky property, light property or geometry.

However, a key event can only store one change per property at specific point in time for each object in the scene. This means that at a single point in time, you can only have one change in position, size, material or geometry per object recorded as a key event.

If you keep changing the same properties at the same point in time, the changes are recorded on top of existing changes. Only the last change you perform is recorded as the key event.

To record more than one change in the same object's property you have to move to a different point in time. Then each change can be recorded as a separate key event and applied to the animation.

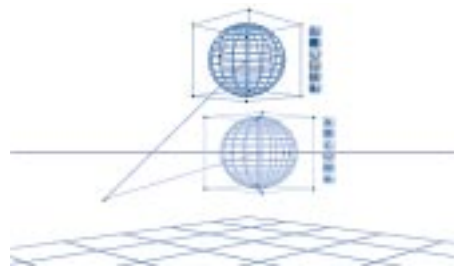

For example, if you move an object up and down at the same point in time, only the last transformation is recorded as the key event...

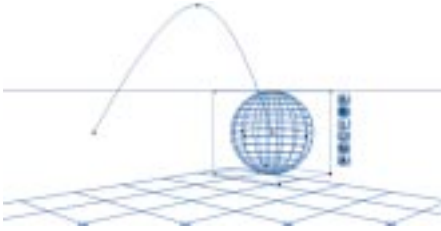

...but if you move the object up at one point in time and then move the object down at a different point in time, both transformations are recorded.

When Auto-Record mode is disabled, the animation system is off. This means that your changes are not recorded as key events, and changes in the timeline do not effect your view in the Working window.

You can continue changing object and scene properties, but they won't be recorded as key events. If you want to record a setting or transformation you'll have to manually add a key frame using the Add Frame button. Refer to "Adding and Deleting Key Frames" on page 365 for more on adding frames.

To enable or disable Auto-Record mode:

- 1** In the Working window, make sure the Animation controls are visible. If it's not, click the Time/Selection Palette toggle.
- 2** Click the triangle icon to the right of the controls and choose Auto-Key. The animation system is on when the option has a checkmark next to it.

Choose Auto-Key again to turn off the animation system.

Recording Key Events in the Editors

When you record a key event in either the Materials Lab or the Terrain Editor, you're only recording a change to the properties associated with the editor.

- In the Materials Lab only changes to an object's material properties are recorded.
- In the Terrain Editor only changes to a terrain object's geometry are recorded.

Previewing Animations

You can preview your animations using either the mini-preview in the movie nano-preview window or by using the Animation Preview controls. Both of these methods allow you to see either a rendered preview or a storyboard.

Using the Movie Preview Window

Using the movie preview window, you can see a rendered version of your animation quickly.

To preview your animation:

- 1** Create an animation.
- 2** Click the Animation Preview Button.

Using the Storyboard Preview

Using the storyboard preview feature, you can review or navigate your animation, frame-by-frame.

To view your storyboard:

- 1** Create an animation.
- 2** Click and hold down on the Animation Preview button.

- 3 Select Storyboard.
- 4 Click on the Animation Preview button.

All of the frames appear in a grid pattern as they are rendered. When the rendering is finished, the movie plays in the movie nano-preview.

To stop the movie preview:

- You can stop the preview at any time by clicking the mouse.

To exit movie preview mode:

- To exit movie preview mode completely, press the Esc key or redraw/render your scene.

Additional Features of the Storyboard

If you pause in the storyboard portion of the animation preview, you can perform various manipulations on your animation. You can:

- Click on a frame to select it.
- Set the current time to that frame.
- Drag the scrubber and move forward or backwards through the animation.
- To render any of the frames, double-click the corresponding storyboard image.

As you perform these manipulations, the animation updates in realtime in the movie preview window.

Using the Animation Controls

When you play an animation, all the frames in the animation within the Working Area are displayed. The preview is shown in Wireframe display mode.



Plays the animation. Click during play to pause the animation.



Stops the animation.



Moves to the beginning of the Recorded Area.

+ Shift moves to the beginning of the animation.



Moves to the end of the Recorded Area.

+ Shift moves to the end of the animation.



Moves one key frame forward in the animation.

+Shift moves one frame forward.



Moves one key frame backward in the animation.

+Shift moves one frame back.



Starts a quick animation preview.

Setting Previewing Options

There are three options you can use to alter the preview of your animation. You can preview the animation only once. You can play the animation continuously, or you cycle forward through the animation, and then back.

To set a preview option:

- 1 Choose **File menu > Animation Setup**. The Animation Setup dialog appears.
- 2 Enable a Play option:
 - Once** plays the animation only once.
 - Repeat** plays the animation continuously.
 - Pendulum** plays the animation forwards then backwards, then forwards, continuously

Adding and Deleting Key Frames

Usually you use the Auto-Record mode to add key frames to your animation, but there are some cases when you would need to force the system create a key frame. For instance, if you accidentally make a number of changes while Auto-Record mode is disabled, you'll have to create a key frame to store your changes, or they'll be discarded when you move to a different point in time.

The Key Frame controls let you add or delete key frames from the timeline. The key Frame indicator changes color when the Current Time Indicator is over a key frame.

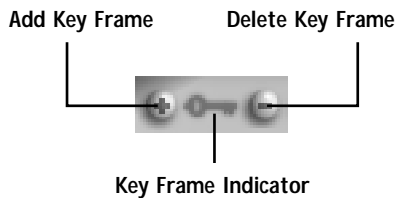

The Key Frame controls let you add and delete key frames from your animation.

Adding Frames

Bryce adds keys frames differently depending on what your selection in the Working window.

If you have an object selected, Bryce only records the changes in property for the selected object. If you have nothing selected, Bryce only records the changes in the sky (i.e. changes you make in the Sky & Fog palette).

You can also modify the add key frame operation so that, for a selected object, only a specific property is recorded as a key event.

To add a key frame:

- 1 Move the Current Time Indicator to the point where you want to add a key frame or
If you need to force Bryce to overwrite an exiting key frame, leave the Current Time Indicator where it is.
- 2 Click the Add Key Frame button.



Any changes you made at this point are recorded in the key frame.

To add a frame for a certain type of property:

- 1 Select an object.
- 2 Hold down the mouse button over the Add Key Frame button and choose an object property from the menu that appears.

To add a key frame for sky properties:

- Make sure there is nothing selected, and click the Add Key Frame button.

or

- Hold down the mouse button over the Add Key Frame button and choose Sky from the menu.

Deleting Frames

As with adding frames, Bryce deletes frames differently based on your current selection.

If you have an object selected, Bryce only deletes the changes in property for the selected object. If you have nothing selected, Bryce deletes the changes recorded for your scene's sky.

You can modify the Delete Key Frame button's function so that only a certain type of object property is deleted.

Adding or deleting frames will effect the shape of an object's motion path.

To delete a key frame:

- 1 Use the Animation Preview controls to move through the key frames until you find the frame you want to delete.
- 2 Click the Delete Key Frame button.



All the properties recorded at that point in time are deleted.

To delete a frame for a specific object property:

- 1 Select an object.
- 2 Hold down the mouse button over the Delete Key Frame button and choose the object property from the menu that appears.

Adding and Deleting Frames in the Editors

When you add a frame in the editors, only the properties associated with the editor are recorded as a key frame.

When you delete a frame in the editors only the properties associated with the editor are deleted. For example, if you delete a frame that contains position, material and scale data in the Materials Lab, only the material data is removed from the key frame.

Advanced Motion Lab

The Advanced Motion Lab provides tools for refining your animations. In this window you can:

- view the hierarchical structure of your scene
- rearrange the sequence of key events for individual object properties
- remap the time it takes to move from one key event to another
- preview your animation.

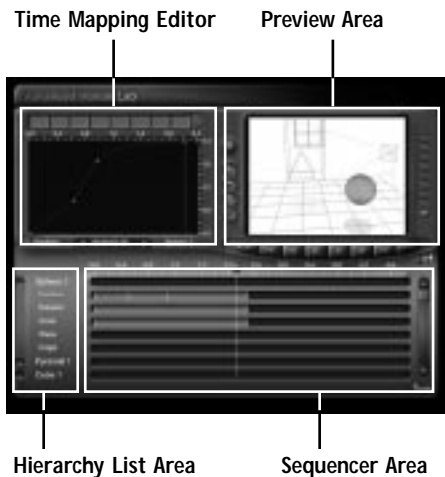

The Advanced Motion Lab lets you adjust the hierarchy of your scene, the speed of objects, and preview the results.

The Advanced Motion Lab is divided into four areas:

The Hierarchy List area, located in the bottom-left corner of the window, displays a visual representation of the object hierarchies in your scene.

The Sequencer area, in the bottom-center of the window, displays timelines containing all the key events in your animation. A timeline is displayed for each object or scene property in the animation.

The Time Mapping Curve Editor, located at the top-left of the window, displays a curve for each object or scene property that represents the time mapping filter applied to the property. You can adjust how long it takes to complete an action by changing the shape of the curve.

The Preview Area, located at the top right of the window, contains tools for previewing your animation.

All the changes you make in the Advanced Motion Lab are automatically applied to your animation.

Viewing Object Hierarchies

The Hierarchy List area displays the hierarchical structure of your scene. The term “hierarchy” refers to the structure of object links and groups in the scene.

The Hierarchy List area is used to control the display of both the object hierarchies and object property timelines. If you want to view only your scene’s object hierarchies you’ll have to hide all the properties for all objects. You can hide each object individually or select from the menu to the right of the Preview Area to display or not display the hierarchy.

Refer to “Object Hierarchies” on page 303 for more on object hierarchies.

To hide an object’s property timelines:

- To hide an individual object’s property timelines, click the name of the object whose properties you want to hide.
- To hide all the property timelines in the Hierarchy List area, either hold down Option/Alt while you click,
 - or
 - select Collapse all timelines from the menu to the right of the Preview Area.

When all the object timelines are hidden, the only thing displayed in the Hierarchy Area is the hierarchical structure of your scene.

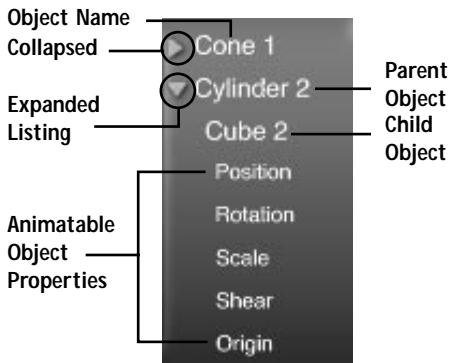

This is what the Hierarchy List area looks like when you've hidden all the property timelines.

The hierarchy list can be viewed in two ways: collapsed or expanded. You can use the arrow icons to expand or collapse the Hierarchy. When the Hierarchy list is collapsed you can only see the Parent objects in the object hierarchies.

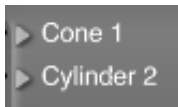

When the Hierarchy listings are collapsed, you can only see the names of the Parent Objects in the scene.

When its expanded you can see all child objects in the hierarchy.



When the Hierarchy listings are expanded, you can view the parent objects and their children.

The indents indicate Parent-child links or groups. The parent is align to the far-left, and its children are indented from there.

To display or hide the hierarchical relationship:

- To display the hierarchical relationship in the hierarchy list area, select Display Hierarchy from the menu to the right of the Preview Area.
- To hide the hierarchical relationship in the hierarchy list area, deselect Display Hierarchy from the menu to the right of the Preview Area

To expand/ collapse the hierarchy list:

- To expand or collapse individual items in the hierarchy list, click the Arrow icon beside an object's listing.
- To expand the entire hierarchy, hold down Option/Alt and click an arrow, or select Expand all hierarchies from the menu to the right of the Preview Area.
- To collapse all hierarchies, select Collapse all hierarchies from the menu to the right of the Preview Area.

A right facing arrow indicates a closed hierarchy, and a down-facing arrow indicates an expanded listing.

Editing Property Timelines in the Sequencer

Each object in the Hierarchy list has a number of timelines associated with it. When you display an object's properties you can see the timelines associated with each object.

To display object's property timelines:

- To display an individual object's property timelines, click the name of the object whose properties you want to display.

- To display all the property timelines in the Hierarchy List area, either hold down Option/Alt while you click, or select Expand all timelines from the menu to the right of the Preview Area.

These timelines represent the various animatable properties for an object type. Different types of objects have different animatable properties.

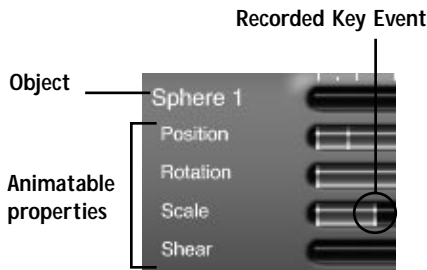

For example, this is the listing for a sphere object. When the object's property timelines are displayed, you can see the key events recorded for each property.

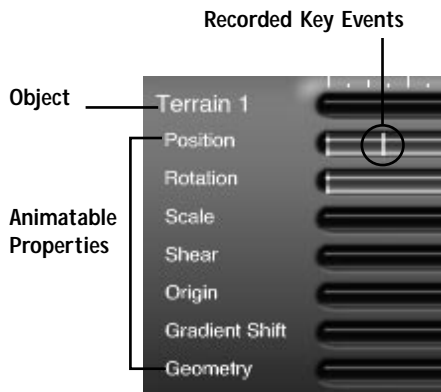

This the listing for a terrain object. Here you can see that there are several different animatable properties. Some properties like position, size, and rotation are common to all objects.

The white tick on a property timeline indicates that a key event has been recorded for the property.

The ruler at the top of the Sequencer lets you see the exact point in time when the key event was recorded.

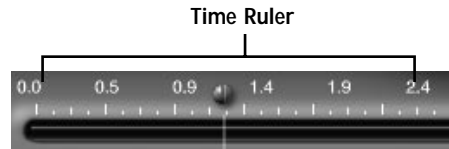

You can tell exactly when an event was recorded by lining the key event marker up with the ruler at the top of the Sequencer area.

In this example, a position key event was recorded at time 00:00:01.25 (or 1 second and 25 frames)

By moving these key events you can control precisely when events occur.

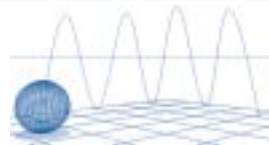
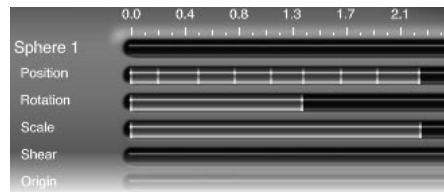

This sequence represents an animation where a ball moves up and down four times, rotates as it makes its third jump and shrinks when its done bouncing.

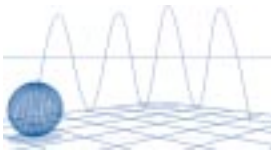
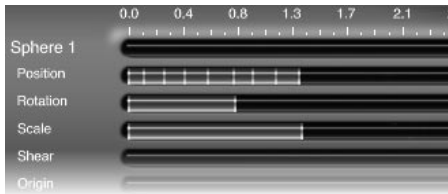

If you move the position key events closer together the bounces occur faster, but the timeline remains the same.

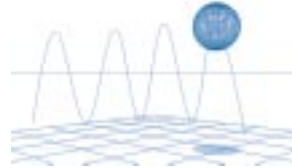
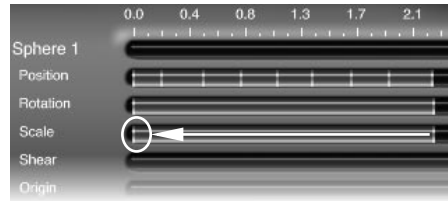

Position is not the only key events you can arrange, here both the rotation and scale key events have been repositioned. Now, the ball grows large as it bounces and rotates only at the end of the animation.

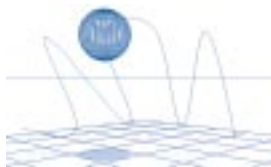
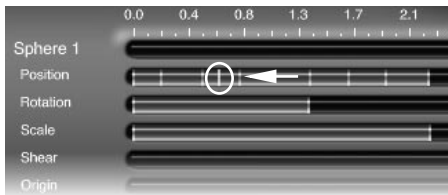

If you move the fourth position key event in front of the third event, you're changing the shape of the motion path, because the ball bounces up before it bounces down.

You should take care when rearranging Position key events as they can greatly alter the trajectory of your object, resulting in unpredictable results.

It's a good idea to activate the continuous preview while your editing the timeline, so you can quickly see the effects of your changes. Refer to "Previewing Animations" on page 363 for more on previewing.

The amount of time available in the Sequencer area is not limited by the current Animation Range. If you position a key event past the current limit of your animation, the Animation Range is automatically extended.

To display an object's property timelines:

- To see specific property timelines, click the name of the object whose properties you want to display, or,
- To display all property timelines, disable Show Selected from the menu at the right of the Preview Area.
- To see property timelines for all animated objects, enable the Show Animated

selection in the menu to the right of the Preview Area.

To move a key event on a timeline:

- 1 Expand the listing you want to edit.
- 2 Click the white tick mark on the listing's timeline.
- 3 Drag the key event to a new position.

To move a group of key events:

- 1 Drag a marquee around all the key events you want to select or hold down Shift and click each of the key events you want to move.
You can select key events on different timelines.
- 2 Drag one of the selected key events. All the other selected key events move also.

To delete a key event from a timeline:

- 1 Select the key event, or group of events you want to delete.
- 2 Press Delete. The key event is removed from the timeline.

To copy a key event on a timeline:

- 1 Hold down Option/Alt and drag a key event. The original remains in the same place, but the copy moves as you drag.

Time Mapping Curves

The Time Mapping editor displays a curve which represents the time mapping curve applied to the events in a property timeline. Each property in the Hierarchy List can have its own time mapping curve. By adjusting the

shape of this curve you can change when events occur and how long it takes to complete an event.

The curve acts like a filter. Time from the actual animation is remapped according to shape of the curve to produce the final time. Depending on the shape of the curve, events can occur faster, or slower.

Time Mapping curves can only remap the time available in the animation. You cannot add more time, or reduce the amount of time in an animation.

Editing Time Mapping Curves

The horizontal axis in the editor displays all the time in the animation. The vertical axis displays the time map for the properties' timeline. The key events recorded for an object property are displayed as horizontal dotted lines. The curve in the middle represents the time mapping filter. The point where the curve intersects a key event line tells you exactly when an event occurs.

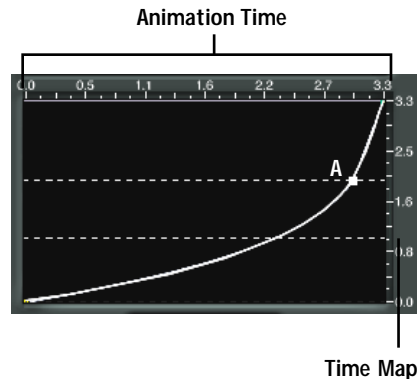

At point A in this timeline, an event that occurred at 2 seconds in the original animation, will occur at 3 seconds after it's passed through the filter.

The default time mapping curve for any property is a diagonal line. In this curve, time is not being remapped since events occur at the same time along both the horizontal and vertical axes.

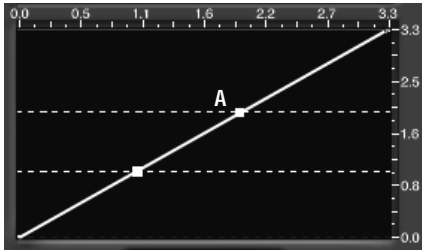

At point A in the default timeline, an event that occurred at 2 seconds in original animation, also occurs at 2 seconds in the time map.

When you change the shape of the default curve, you're remapping time.

For example, if you make the curve convex, events occur later in the animation, but they're closer together which means the action in your animation will speed up.

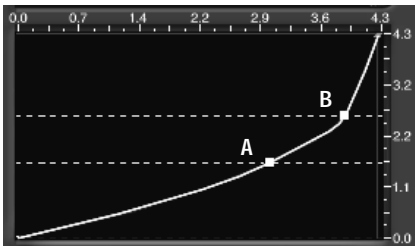

In this example you can see that at point A an event that occurred at 1.5 seconds now occurs at 3.1 second. At point B an event that occurred at 2.5 seconds now occurs at 3.9 seconds.

Although both events now occur later, there's much less time between them, so the action in your animation occurs later but faster.

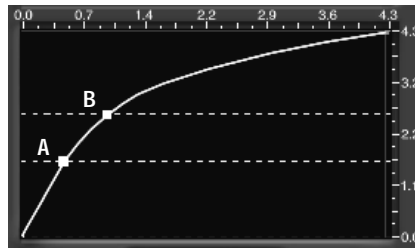

A concave curve would create the same type of effect, except that the events occur earlier. Here, event A and B occur much earlier, within the first second, and the amount of time between them is much shorter.

Different curve shapes represent different time mapping effects. A flat curve means that no motion is occurring since all the events on the curve are happening at exactly the same point in time.

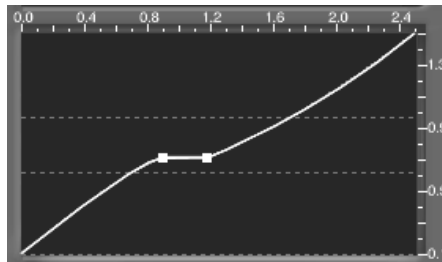

This curve indicates that a pause, or stop of motion occurs during the course of the animation.

A steep jump in the curve indicates a sharp increase in speed, as many events occur in a very short time.

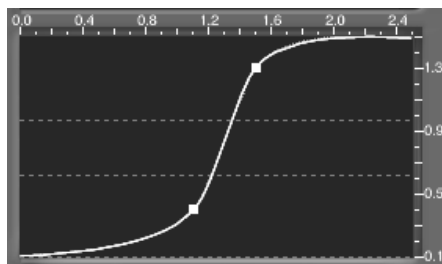

This curve indicates a sharp increase in speed.

An oscillation in the curve, indicates that events repeat, since they intersect the curve more than once.

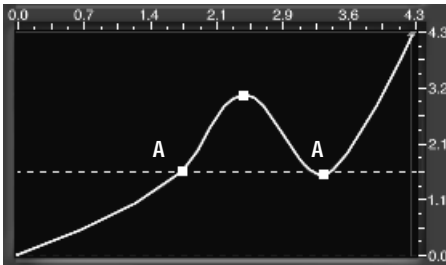

In this curve event A occurs once at 1.5 seconds and again at 3.5 seconds.

You can combine any variation of curve slopes to create different velocity effects.

While you're editing a Time Mapping curve, you may want to continuously run the animation preview. As the preview runs, the cross-hairs in the Time Mapping editor moves from the beginning or the animation to the end. This way you can quickly see the effects of your edits. Refer to "Previewing Animations" on page 363 for more on continuous preview.

The counter at the bottom of the editor shows you the current time of the animation. As the animation runs, the counter updates to continuously show the current time.



Watch the counter as you preview your animation to see the current time.

You can also move the current time by dragging the Current Time bar in the Hierarchy area.

To edit a Time Mapping curve:

- 1 Display the Advanced Motion Lab.
- 2 Click the name of the object whose properties you want to remap

- 3 Click the name of the property you want to remap.
- 4 In the Time Mapping Editor, click a point on the curve and drag it to a new location.
 - If you move over an existing point the cursor changes to a cross-hairs.
 - If there is not point on the curve, the cursor turns into a pen.
- 5 Continue dragging points until you achieve the desired shape.

To zoom into an area of the Time Mapping curve:

- 1 Move the cursor over the curve in the Time Mapping Editor.
- 2 Click and drag over an area of the curve. When you release the mouse, the area is enlarged.

To zoom out of an area in the Time Mapping curve:

- Hold down the Shift key and click inside the Time Mapping editor.

To pan the Time Mapping curve:

- To pan, press the Spacebar and drag the curve in the editing window.
- To reset the view in the Curve Editor, press Cmd/Ctrl + Shift + Click.

Using Presets

Above the Time Mapping Curve Editor are eight time mapping curve presets.

You can create a preset of the current curve then apply it to a different attribute of the same object or to another object.

To add, apply, or remove a preset:

- To add a preset, click in one of the blank squares.
- To apply a preset, click in the square that displays the present you want to apply.
- To remove a present, press Option/Alt and click on the square that displays the preset you want to delete.

When all the preset slots are filled, a new one is automatically generated when you click on the right arrow.

- To scroll to the newest present or to the next preset in line, click on the end of the present container.

Previewing the Animation

The Preview Area in the Advanced Motion Lab lets you see a preview of your animation as you edit the Hierarchy or the Time Mapping curves.

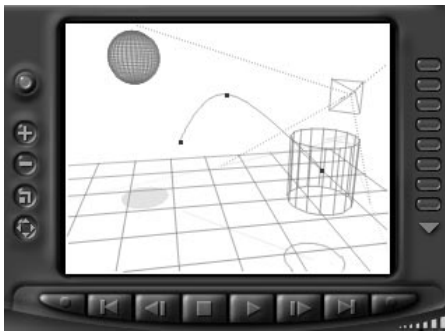

The Preview Area in the Advanced Motion Lab displays the results of your changes to the Hierarchy or Time Mapping curves.

Any change you make in the lab is automatically applied to the preview. When you play the preview you see the effects of your changes.

Once a start playing the animation, it will run continuously until you press the Stop button. Running the preview also moves the Current Time Bar in the Sequencer area and the cross-hairs in the Time Mapping editor. As well, the counter at the bottom of the Time Mapping editor displays the current time of the animation as it plays.

To preview an animation:

- Click the Play button in the Preview Area controls.



The animation starts running. It will continue playing until you press the Stop button.

Click the stop button to stop the preview.



The controls along the left side of the Preview Area control several options for your animation preview.

To switch between Camera View and Director's View in the preview:

- Click the Swap Views button next to the Preview Area.



When you first open the Advanced Motion Lab, the Preview Area displays the current camera view.

In Director's View you'll be able to see the camera in the scene.



Camera View



Director's View

When you switch to Director's View in the Preview Area you can see the camera in the scene.

- Click the button again to switch back to Camera View.

Changing views in the Preview Area doesn't affect the view in the Working window.

To render your preview:

- To render your preview, click the last VCR button under the Preview Area in the Advanced Motion Lab.



When you click on the last VCR button, your wireframe in the Preview Area is rendered.

To change the view in the Preview Area:

- To orbit around your scene, drag the preview in the direction you want to move the view of your scene.
- To change the position of camera, hold down Option/Alt and drag the preview.

To zoom in and out of the preview:

- Click the + button next to the Preview Area. The view of the scene enlarges.



- Hold down Shift and click the + button to zoom out.

To reset the view in the preview area:

- Click the Reset button next to the Preview Area.



The view switches back the view displayed when you first entered the Advanced Motion Lab.

To pan the Preview Area:

- Drag the cursor over the Pan button next to the Preview Area.



Hiding and Displaying Objects

The left side of the hierarchy area displays a list of all the objects in your scene. The icons on the left side of the listing indicates whether or not the object is displayed in the preview area.

Visible Object



Hidden Object

The eye icon indicates whether or not an object is hidden.

When you hide an object it does not appear in the Preview Area at the top of the Advanced Motion Lab. This setting has no effect outside the lab. Objects that are hidden in the lab will be visible in the Working window and will still render normally.

You can use this feature to isolate objects that your editing in the Sequencer or Time Mapping areas.

To hide/display an object:

- Click the Eye icon to hide the object.
Click the icon again to display the object.

Saving Preview Positions

The Memory dots next to the Preview Area let you save specific camera positions in the preview for later use.



The Memory Dots on the right side of the Preview Area let you save positions in the Hierarchy area and the animation preview.

To save a position:

- 1 Play the animation and then stop it at the point you want to save.
or
Move the Current Time bar in the Hierarchy area to the position you want to save.
- 2 Click on an empty Memory dot on the right side of the Preview Area.

A dot is empty when it appears gray.

To move to saved position:

- Click on a full Memory dot. A dot is full when it appears purple.

To delete a saved position:

- Option/Alt+click on a full Memory dot.

Motion Paths

A motion path is a visual representation of an object's trajectory as it moves through time.

An object's motion path is automatically generated as you create key events. Each new key event adds a new point to the path.

The shape of the curve is determined by the interpolation performed by Bryce. In most cases Bryce tries to create smooth motion so the path is drawn as a curve.

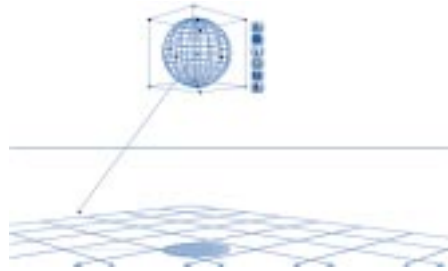

An object's motion path is automatically generated as you create key events. As you move the object at a specific point in time, the motion path line extends out from the object's wireframe.

As you add key events, the curve is adjusted to include the new motion.

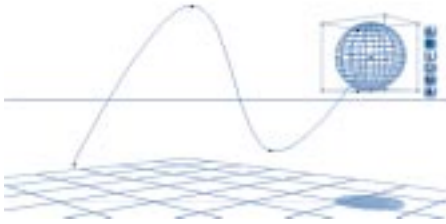

As you add more key events to your animation, the path changes shape to include the new motion. Bryce always keeps the motion smooth, so each new point is added as a curve.

Motion paths exist in 3D space so they can be viewed from any angle. If you move the camera, you can see how the object moves along the X, Y and Z axes.

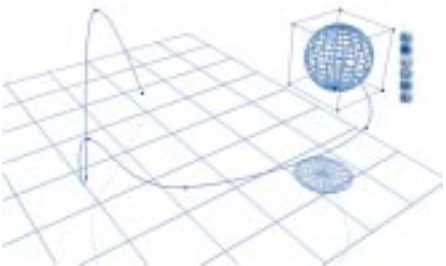
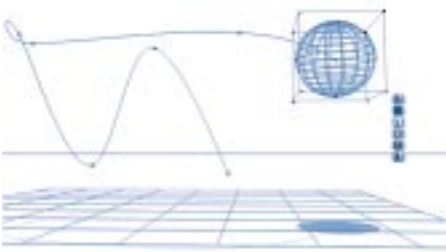

If you move the camera to different views, you'll be able to see the object's trajectory along all three axes.

The default state of the motion path can be difficult to see in a complex scene. You can give your motion path some extra depth by displaying it as a ribbon.

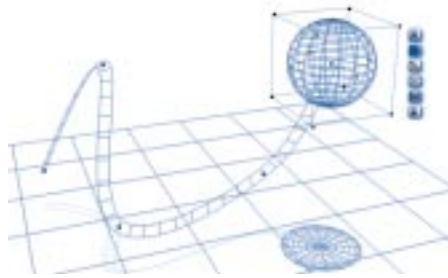

The ribbon lets you see the motion path as a flat track running through the scene.

By default, the motion path for an object only appears when the object is selected. Otherwise the path is invisible. As well, it does not render in the final animation.

You can change the display mode of the motion path in the Animation tab of the Object Attributes dialog.

To show the motion path as a ribbon:

- 1 Select the object.
- 2 Click the A icon that appears next to its bounding box. The Object Attributes dialog appears.
- 3 Click the Animation tab.
- 4 Enable the Show as Ribbon option and click the OK icon.

To display the path only when the object is selected:

- 1 Select the object.
- 2 Click the A icon that appears next to its bounding box. The Object Attributes dialog appears.
- 3 Click the Animation tab.
- 4 Enable the Show Only when Selected option and click the OK icon.

To display the path at all times:

- 1 Select the object.
- 2 Click the A icon that appears next to its bounding box. The Object Attributes dialog appears.
- 3 Click the Animation tab.
- 4 Enable the Show Always option and click the OK icon.

Editing Motion Paths

Changing the shape of the motion path changes the trajectory of the object. The path acts like a Bezier curve. You can change its shape by dragging its control points.

You don't have to be in Auto-Record mode to edit the path. The changes you make to the path's shape are applied directly to path the in real time.

Changing the shape of a path does not affect when key events occur. A key event that occurs at 00:00:01.00 will still occur at the same time regardless of where it

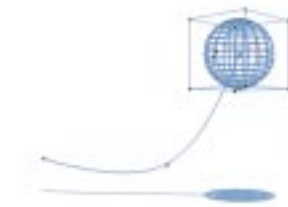

For example, the events on the path above occur at 00:00:00.01, 00:00:01.00 and 00:00:02.00. When you change the shape of the path, the direction in which the object travels changes, but all the events still occur at the same they did in the original path.

Since Bryce treats the motion path as a Bezier curve, you can edit it just as you would any curve in any 2D illustration application. You can also display the curves tangents which indicate the angle of the curve.



When you display the path's tangents you can see the angles of its curve points.

Motion Path Modifiers

There are a number of modifiers you can apply to the path change the way motion occurs along the path.

Normally an object moves from the first key event on the path to the last over the course of the animation. If you want the object to move backwards along the path, or repeat its action, you would have to reposition the object and set up new key events. The modifiers let you create these types of effects automatically.

For example, if you wanted to animate the motion of a grandfather clock pendulum, you have to set up the forward motion, and then the backward motion.

However, using the Pendulum modifier you just have to set up the forward motion path. Since the modifier changes the object's behavior so that it moves forward than back along the same path during the course of the animation. All you have to do to see the new motion is extend the duration of the animation.



The motion of this clock's pendulum was created using the Pendulum modifier.

There are four modifiers available:

- **Make One Shot** restores the motion of the path its original configuration, meaning the action along the path only occurs once.
- **Make Repeat** creates a loop in the action. The motion on the path repeats continuously.
- **Make Pendulum** creates a repeating cycle in the action along a path. The object will move forward on the path, then back and then forward continuously.
- **Make Circular** closes the path to create a circular path. The object will move along the path and when it hits the end, it'll swing around to the front of the path and start all over.

To apply a modifier to a motion path:

- 1 Select the object.
- 2 Click the A icon that appears next to its bounding box. The Object Attributes dialog appears.
- 3 Click the Animation tab.
- 4 Enable a modifier.
- 5 Extend the duration of the animation so you can see the change in motion.

Moving the Path

You can also move the path, by dragging it to a new location. When you drag the path, all the events on the path shift position. Changes in motion path position are not recorded as key events.

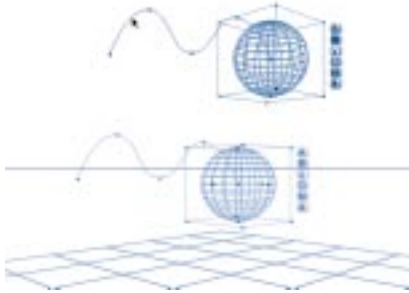

When you drag the motion path, you're not changing its shape, you're adjusting the position of all the events on the path, so this animated ball occurs at a higher altitude.

To move a motion path:

- Click on a section of the path that does not contain any control points and drag it to new location.

You have to click on a part of the path without control points, otherwise you'll change its shape.

Aligning Objects to the Path

Normally, the center of object remains perpendicular to the motion path as it moves from point to point. Using the aligning option you can have the object's center remain parallel to the path so that it reorients itself as moves from point to point

You can use this option to create more realistic motion for objects that have a distinct front and back.



For example, the motion of this airplane looks rather unrealistic since its rising and falling without tilting.



If you align the airplane to its path, the airplane's nose tilts down as it moves down and up as it moves up.

There are two align options available:

- **Do Not Align** disables aligning. The shape of the curve has no effect on the object's orientation.
- **Align** adjusts the object so that its orientation is matches the shape of the path.

To align an object to a motion path:

- 1 Select the object.
- 2 Click the A icon that appears next to its bounding box. The Object Attributes dialog appears.
- 3 Click the Animation tab.
- 4 Enable an alignment option and click the OK icon.



15

Animating Techniques

Introduction

Bryce has several features you can use to add realism to your animations. The techniques covered in this chapter can be used together to help you develop more exciting, natural and dynamic animations.

In this chapter you'll learn how to animate objects using the Tracking feature. You'll also learn how to animate several different properties of your scene like material channel properties, which can dramatically alter the look of your objects, and terrain object properties, which can alter the layout of your landscape.

Tracking Objects

Tracking lets you connect an object to another, called the *target*, so that the object remains pointed at the target throughout the animation.

As the target moves, the original object pivots around its origin so that it remains pointed at the target. Normally, the original object does not change position, only orientation. However, if you offset the object's origin point, it might change location as it rotates around the offset point.



When an object tracks a target object, it remains pointed at the target object no matter where it moves in the scene.

You can use tracking to quickly set up the animation of a number of objects at once. When an object is tracking another, you only have to set up the motion path of the target object. The motion of the objects tracking the target are automatically created.

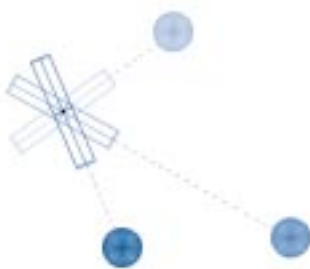

The original object pivots around its origin point so that it's always facing the target object.

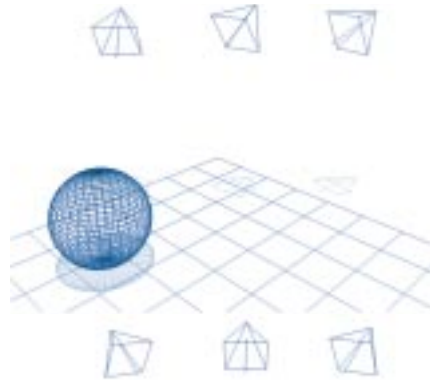

For example, in this scene the motion of all the lights is created when you move the target object.

You can also use this feature to ensure that a light or the camera remains pointed at an object during the entire course of the animation. You can also use it to create motions like a radar dish following a satellite or a sunflower following the sun.

A parent object cannot track its child object.

To set up object tracking interactively:

- 1 Select the object you want to remain stationary (that is, the one that tracks the target object).
- 2 Move the cursor over the target icon that appears next to the object's bounding box.
- 3 Drag the Target line from the icon to the target object. The target object turns blue.



As you drag the Tracking icon from the tracking object to the target, a tracking line appears.

To set up object tracking using the Object Attributes dialog:

- 1 Select the object you want to remain stationary.
- 2 Click the A icon that appears next to the object's bounding box. The Object Attributes dialog appears.
- 3 Click the Linking tab.
- 4 Click the Target Object Name menu and choose the name of the target object.

Animating the Camera

When you animate the camera, you're changing the view of your scene over the course of the animation. Since you're in 3D space you can move the camera to any position in the scene. You can have your camera circle around the scene, zoom into it or even fly under it.

There are two ways of animating the camera in Bryce: using the Camera Position controls, or by moving the camera as an object.

The easiest way of animating the camera is to use the Trackball, (or other Camera Position controls) in Camera View while Auto-Key mode is enabled. Any changes you make to the position of the camera are automatically recorded as part of a key event. When you play the animation, your camera changes are added to all the other changes in scene properties to create the action in your animation.

While working in Camera View may be the easiest way of animating the camera, it's not the most precise. Because of the view's first person perspective, it can be hard to see the exact path of the camera as it moves. This can make creating a precise motion difficult.

However, if you switch views, to an orthogonal view or the Director's View, you'll be able to see the camera as an object in the scene. Then you can select the camera and set up key events for its position, just as you would for any other object. Also, you can display the camera's motion path so you can make precise adjustments to its movements.

After you're done setting up the key events for the camera, you can see the changes in the Sequencer in the Advanced Motion Lab. There you can rearrange the order of events or change how long it takes to move between camera positions. Refer to "Object Hierarchies" on page 303 for more on working in the Hierarchy.

or “Time Mapping Curves” on page 371 for more on remapping time.

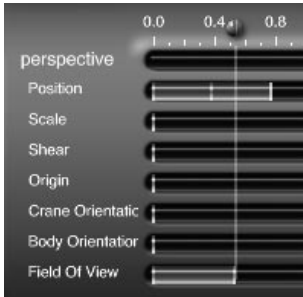

After you’re done adjusting the position of the camera, you can see the events recorded for the changes in the Hierarchy Area.

Camera Motion and Skies

The motion of sky elements can affect how fast the action in your animation appears. For example, in time-elapsed movies, the clouds and sun fly by quickly as the objects stay in the same position. You could inadvertently create this type of action in your scene if you move only the camera in the scene without considering the static nature of the sky elements. Since the clouds stay in exactly the same position as you move the camera, they’ll appear to be moving much faster than the objects in the scene.

To avoid this problem, Bryce lets you link the clouds to the camera. This way, whenever the camera moves, the cloud positions also move, so they look like they’re staying in the same position.

Although you can also link the sun to the camera, it’s not a very good idea to link the two during an animation since any change in the camera position will change the time of day.

To link clouds to the camera:

- 1 Display the Sky & Fog palette.

- 2 Click the triangle icon in the bottom right corner of the palette and choose Sky Lab from the menu. The Sky Lab dialog appears.
- 3 Click the Cloud Cover tab.
- 4 Click the Link Clouds to View button at the bottom of the palette.
- 5 Click the OK icon to exit the palette.

Using the Orthogonal Views

In Camera View you can’t see the physical position of the camera in the scene since you’re looking through it, but using one of the Orthogonal views (Top, Bottom, Left, Right, Front and Back) you’ll be able to see the camera as an object.



In this example, the scene is displayed in Top view. Here you can see the exact position of the camera in the scene.

In these view you can animate the camera by changing its position at different points in time. When you run the animation, Bryce fills in the gaps between positions to create smooth camera motion.

To animate the camera in an orthogonal view:

- 1** In the Working window, click the triangle icon next to the View Control and choose an orthogonal view from the menu: Top, Left, Right, Bottom, Front or Back.
- 2** Move the Current Time Indicator in the Timeline to the point where you want to start changing the Camera View.
- 3** Click the triangle icon in the Animation controls and make sure Auto-Key is enabled.
- 4** Drag the Camera wireframe in the Working window to a new position.
- 5** If you want to see the results of your changes, choose Camera View from the View Control menu and click the Play button in the Animation controls.

Using Director's View

Director's View is similar to Camera View, except that in this view, you can see the camera as an object in the scene and the movements of the Director's camera are not recorded as key events.

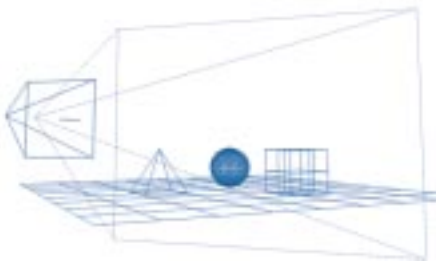

In Director's View you see the camera as an object in the Working window. You can change this view using any of the Camera Position controls in the Control Palette.

In Director's View, you can move the view of the scene using the Trackball or the Camera Position tools. The view of the scene changes in the Working window, but no new key events are created.

You can also preview the animation while in Director's View. In the Working window you can see all the object's moving along their motion paths— including the camera.

To animate the camera using Director's View:

- 1** In the Working window, click the triangle icon next to the View Control and choose Director's View from the menu.
- 2** Move the Current Time Indicator in the Timeline to the point where you want to start changing the position of the camera.
- 3** Click the triangle icon in the Animation controls and make sure Auto-Key is enabled.
- 4** Drag the Camera wireframe in the Working window to a new position.
- 5** If you want to see the results of your changes, click the Play button in the Animation controls.

Displaying the Camera's Trajectory

If you're setting up a precise path for the camera, you may want to display its motion path. Just like with other motion paths, you adjust the trajectory of the camera by adjusting the shape of the path. Refer to "Editing Motion

Paths” on page 378 for more on working with motion paths.

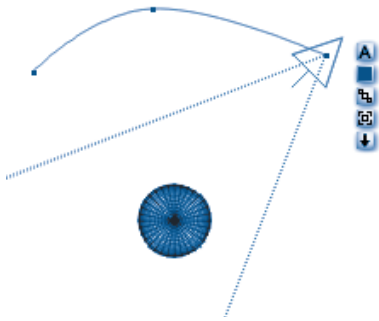

When you display the camera's trajectory, you can see the exact path it will take during the course of the animation.

To display the camera's trajectory:

- 1 In the Working window, click the triangle icon next to the View Control and choose: Top, Left, Right, Bottom, Front or Back from the menu.
- 2 Select the Camera in the Working window.
- 3 Click the A icon that appears next to the camera's bounding box. The Camera & 2D Projection dialog appears.
- 4 Click the Animation tab.
- 5 Click the Show Trajectory option and click the OK icon.

Linking and Tracking with the Camera

Since Bryce lets you treat the camera as an object, you can also link the camera to an object, or you can have it track an object.

When you link the camera to an object, the view of the scene changes as the position of the parent object changes.



For example, if you link the camera to an airplane, the view of the scene will follow the airplane's trajectory as it moves along its motion path.

When the camera is linked to an object, both its aim and position change as the object changes.

When you set the camera to track an object, the camera remains pointed at the target object no matter where the object moves in the scene. This means the Trackball is disabled because the orientation of the camera is controlled by the position of the target object. Also, you can't change the aim of the camera because it always aims at the target object.

However, you can position the camera using the Camera controls as these controls change the position of the camera not its orientation.



For example, if you link the camera to an airplane, the view of the scene will follow the airplane's trajectory as it moves along its motion path.

Linking the camera can cause unpredictable movements when you're in Camera View. If you change the position of the target object, the view of the scene will also shift.

To link the camera to an object using the Camera & 2D Projection dialog:

- 1 Switch to an orthogonal view or Director's View.
- 2 Select the Camera.
- 3 Click the A icon that appears next to the camera's bounding box. The Camera & 2D Projection dialog appears.

You can also access the dialog by double-clicking the Trackball, or choosing **Edit menu > Current Camera**

- 4 Click the Linking tab.

- 5 Click the Object Parent Name menu and choose the name of the object you want to use as the parent object.

- 6 Click the OK icon to link the two objects.

To link the camera to an object interactively:

- 1 Switch to an Orthogonal view or Director's View.
- 2 Select the Camera.
- 3 Move the cursor over the Link icon that appears next to the camera's bounding box.



- 4 Drag the linking handle from the icon to object you want to use as the parent object.

To force the camera to track an object using the Camera & 2D Projection dialog:

- 1 Switch to an orthogonal view or Director's View.
- 2 Select the Camera.
- 3 Click the A icon that appears next to the camera's bounding box. The Camera & 2D Projection dialog appears.
- 4 Click the Linking tab.
- 5 Click the Track Object Name menu and choose the name of the target object.
- 6 Click the OK icon.

To force the camera to track an object interactively:

- 1 Switch to an orthogonal view or Director's View.
- 2 Select the Camera.

- 3 Move the cursor over the Tracking icon that appears next to the camera's bounding box.



- 4 Drag the tracking handle from the icon to the object you want to use as the target object.

Creating Camera Orbits

The camera's origin point controls its center of rotation. When the origin point is at the camera's center, it rotates around in place. When the origin is positioned somewhere in the scene, it will orbit around the origin point. During an animation, the view of your scene will orbit around a specific point in the scene.



In this example, the camera's origin point was positioned in the center of the scene. During the course of the animation, the camera appears to orbit around the entire scene.

To create a camera orbit:

- 1 Switch to Director's View or one of the orthogonal views.
- 2 Click the triangle icon in the Animation controls and make sure Auto-Key is enabled.

- 3 Click the Camera wireframe in the Working window.
- 4 Click the A icon that appears next to the camera wireframe. The Camera & 2D Projection dialog appears.
- 5 Click the General tab.
- 6 Click the Show Origin Handle button and click the OK icon.
- 7 Drag the ring handle to a position in the scene.
- 8 Rotate the object using the Rotation tool in the Edit palette or the Trackball.

Animating Materials

The action in your scene can include much more than just motion. Many subtle or dramatic effects can be created by changing the properties of an object's surface over the course of the animation.

This section assumes that you're familiar with the concepts and procedures involved in creating material and textures. Refer to "Building Materials" on page 230 for more on creating materials and "Textures" on page 237 for more on editing textures.

By animating an object's texture you can create subtle effects like changing the color of an object to simulate things like a tomato ripening. You can also create more dramatic effects like changing all the properties of a material at

once. Using this technique you can change an object from marble to metal, or glass to wood.



In this animation, the illusion of a banana ripening was created by changing the color and texture of a material over time.

In Bryce, animating materials is a rather straight-forward process. Using the animation tools in the Materials Lab you set the properties of a material at different points along the Timeline. When you run the animation, Bryce interpolates between the properties to create a transition from one material to the other.

You can animate any property of a material:

- Colors
- Channel values
- Texture component usage (that is, switching between components A, B, C and D)
- Texture properties
- Volume Material properties

Take care when you're choosing which properties to animate. Some properties, like transparency, and volumetric effects can greatly increase the rendering time or your animation.

Material animations are created using the Animation controls at the bottom of the Materials Lab.

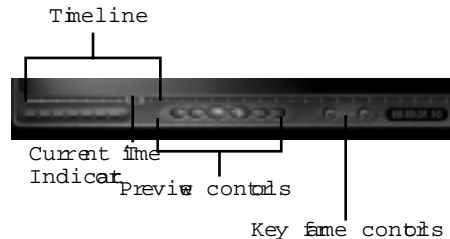

The Animation controls at the bottom of the Materials Lab lets you move along the Timeline and preview your animation.

These controls let you move along your animation's timeline. This timeline is the same as the one at the bottom of the Working window. It contains all the same key events as the Working window timeline. The Animation controls in the Materials Lab can perform all the same features as the Animation controls in the Working window.

Animating Material Channel Values

By animating the channels in a material you can alter the properties of a material without changing its basic function. Using this technique, a rock material would still look like a

rock, but change color, or glass would still look like glass except become shinier.



In this example, the effect of a cat's eyes growing brighter as the sunlight fades, was created by animating the Ambience channel value.

This is the simplest way of animating a material and it requires the least amount of processing time.

To animate a material's channel values:

- 1 Select an object.
- 2 Click the M icon that appears next to the object's bounding box. The Materials Lab appears.
- 3 Click the triangle icon in the Animation controls and make sure Auto-Key is enabled.
- 4 Move the Current Time Indicator to the point where you want to start changing the material.

- 5 Change the values of the material channels using the Value controls.

or

Change the color used for a channel by using the color picker.

- 6 Move the Current Time Indicator to a different point on the Timeline.

The current time appears in the counter next to the preview controls.

- 7 Change the channel values again.

- 8 Continue moving the Current Time Indicator and changing channel values until you achieve the effect you want.

- 9 Click the OK icon to exit the Materials Lab.

Animating Texture Components

Animating a texture component is an effective way of creating motion within a material. When you change the orientation, position or scale within a texture component, the texture elements, (like dots, checks or patterns) will appear to move.

You can use this technique to create realistic wave motion in a water texture. If you change the position of the texture pattern at different points in the Timeline, the waves will appear to move over the surface of the object.



This tide effect was created by changing the makeup of the water texture in the material applied to the water slab.

If you wish to avoid unexpected texture movement during a texture animation, use Object Space mapping mode for the texture. This way the texture moves as the object moves. However, you can create some very interesting effects using World Space.

You can also animate a texture component by altering the makeup of the texture using the Deep Texture Editor. Using the editor you can change the make-up of any or all of the four texture components in a material.

To animate a material's texture components:

- 1 Select an object.
- 2 Click the M icon that appears next to the object's bounding box. The Materials Lab appears.
- 3 Click the triangle icon in the Animation controls and make sure Auto-Key is enabled.

- 4 Move the Current Time Indicator to the point where you want to start changing the material.
- 5 Click the button in the upper left corner of the texture component window. The Edit Texture palette appears.



Click the button in the upper left corner of the Texture Component window to display its transformation controls.

- 6 Adjust the position, orientation or scale of the texture and click the OK icon to exit the controls.
- 7 Click the pink button in the upper-left corner of the texture component window. The Deep Texture Editor appears.



Click the pink button in the upper left corner of the Texture Component window to display the Deep Texture Editor.

- 8 Adjust the values of the texture's components and click the OK icon to close the editor.
- 9 Move the Current Time Indicator to a different point on the Timeline. The current time appears in the counter next to the preview controls.
- 10 Change the texture properties again.
- 11 Continue moving the Current Time Indicator and changing texture properties until you achieve the effect you want.
- 12 Click the OK icon to exit the Materials Lab.

Animating Between Materials

Animating channel values or texture components is a good way of creating subtle effects in a material, but to create more dramatic action, you'll need to animate between two completely different materials.

This is how you create a transition from rock to glass, or wood to metal.



The transition between rock and glass in these temple columns was created using two completely different materials.

Animating between materials is exactly like creating two different materials for the same object. As long as the Auto-Key mode is enabled, all your settings are recorded as key events, so you can set up a material at one point in time and then move to a different point on the Timeline and create a completely different material.

There are two quick ways of creating different materials:

- By switching the Texture Component used to set a material channel, you can completely change the color, pattern, or bumpiness of a texture.
- Using the Preset Materials Library, you can quickly apply a different material to the object.

To animate between materials:

- 1 Select an object.
- 2 Click the M icon that appears next to the object's bounding box. The Materials Lab appears.
- 3 Click the triangle icon in the Animation controls and make sure Auto-Key is enabled.
- 4 Move the Current Time Indicator to the point where you want to start changing the material.
- 5 Set up a material by setting channel values and texture components.
- 6 Move the Current Time Indicator to a different point on the Timeline.
The current time appears in the counter next to the preview controls.
- 7 Set up a different material by choosing different components or applying a preset.
- 8 Click the OK icon to exit the Materials Lab.

Previewing Material Animations

Any change you make to a material's properties are displayed in the Material Preview area. When you play a material animation, the same preview area shows you the transition of the material from one key event to the other.

This is not the most effective way to see a material animation. The best way of seeing a material transformation is by rendering the scene.



The Material Preview area displays the preview of your material animation.

To preview a material animation:

- Click the Play button in the Animation controls at the bottom of the Materials Lab. Click the Stop button to stop the preview.

Animating Skies

All the properties of a Bryce sky can be animated. This means that any attribute you can set in the Sky & Fog palette or the Skylab dialog can be animated using the Animation controls on the Timeline.

This section assumes that you're familiar with the concepts and procedures involved in creating skies. Refer to "Creating Skies" on page 123 for more on creating skies.

By changing the attributes in the Sky & Fog palette at different points in the time, you can

animate everything from the position of the sun to the color of the clouds.



For example, you can simulate changes in the time of day by changing the position of the sun over time.

There are several techniques you can use to add motion to your skies. You can animate all or some of the properties of your sky. You can activate and deactivate sky effects at different points in the animation. You can also animate the position of the sun or moon.

Sky animations are created using the Animation tools in the Working window and the Sky Lab dialog.

Animating Sky & Fog settings

Animating Sky & Fog settings changes the properties of a sky over time. For example a scene can become cloudier, or darker during an animation. The intensity of the change depends

on how many properties you adjust and the amount of each adjustment.



In this example, the animation of approaching storm clouds was created by changing the Cloud Frequency and Amplitude value and the Cloud Color at different points in the Timeline.

Most Sky & Fog properties can be changed using the thumbnail controls. Other settings are available in the Skylab dialog.

You won't be able to see the effects of a sky animation until you render the entire animation.

To animate Sky & Fog settings:

- 1 Click the triangle icon in the Animation controls and make sure Auto-Key is enabled.
- 2 Move the Current Time Indicator to the point in the Timeline where you want the sky to change.
- 3 Adjust the sky's properties using the Sky & Fog palette controls.

- 4 Move the Current Time Indicator to a different point on the Timeline.
- 5 Change the properties of the sky again.
- 6 Continue moving the Current Time Indicator and changing the sky's properties until you achieve the desired effect.

Animating Clouds

You can create the effects of wind in your environment by setting up cloud motion parameters. Based on your settings, Bryce automatically moves the clouds in your environment to create motion.

Cloud motion parameters are set in the Sky Lab dialog.

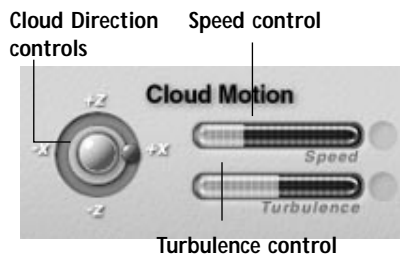

The Cloud Direction control lets you set the direction for cloud motion, while the other controls set the speed and distortion of the clouds.

To animate clouds:

- 1 Click the triangle icon in the Animation controls and make sure Auto-Key is enabled.
- 2 In Sky & Fog palette, click the Sky Lab button. The Sky Lab dialog appears.
- 3 Click the Cloud Cover tab.
- 4 Move the direction indicator in the Cloud Motion controls to set a direction for the clouds as they move in the animation.

- 5 Adjust the speed control to set how fast the clouds move. You can also enter a speed value.
- 6 Adjust the Turbulence control to set how much the clouds will distort as they move. You can also enter a turbulence value.

Animating Environmental Effects

Many environmental effects like rainbows and fog are not permanent features of sky. They appear for a brief time and then fade way. You can simulate this action by changing the properties of the environmental effects at different points along the Timeline.



The natural appearance and disappearance of this rainbow was created by changing the rainbow density over time.

Environmental effects controls are located on the Atmosphere tab of the Sky Lab dialog. You can also animate the various settings for an

effect. For example, the radius of moon rings can increase or decrease during the course of your animation.

To animate environmental effects:

- 1 Click the triangle icon in the Animation controls and make sure Auto-Key is enabled.
- 2 Move the Current Time Indicator to the point in the Timeline where you want the sky to change.
- 3 Display the Sky Lab dialog: Atmosphere tab and change the properties of an effect.
- 4 Move the Current Time Indicator to a different point on the Timeline.
- 5 Change the properties of the effect again.
- 6 Continue moving the Current Time Indicator and changing the effect's properties until you have the desired effect.

Animating Sun or Moon Position

One of the most spectacular effects you can create using the scene's sky is elapsed time. In the great outdoors we perceive time in relation to the position of the sun and the brightness of the sky. By changing the position of the sun or

moon you can simulate time passing in terms of days or months.



In this example, the passage of time is simulated by the change in the sun's position.

Since all the elements in the sky are linked, the other properties of the sky like Ambient Light change as the position of the sun changes, adding to the realism of the effect.

For the moon, you can also change its phases, so you simulate the passage of an entire month just by adjusting the moon attributes.

To animate Sun or Moon position:

- 1 Click the triangle icon in the Animation controls and make sure Auto-Key is enabled.
- 2 Move the Current Time Indicator to the point in the Timeline where you want the sky to change.

- 3 Adjust the position of the sun or moon using the Sun Position control in the Sky & Fog palette.
- 4 Move the Current Time Indicator to a different point on the timeline.
- 5 Change the position of the sun or moon again.
- 6 Continue moving the Current Time Indicator and changing the sun or moon position until you achieve the desired effect.

Animating Terrains

Terrain objects are animated by changing their properties in the Terrain Editor.

This section assumes that you're familiar with the concepts and procedures involved in creating terrains. Refer to "Creating Terrains" on page 164 for more on creating and editing terrains.

By changing the shape of your landscape at different point on the Timeline you can simulate geological events like earthquakes or erosion.

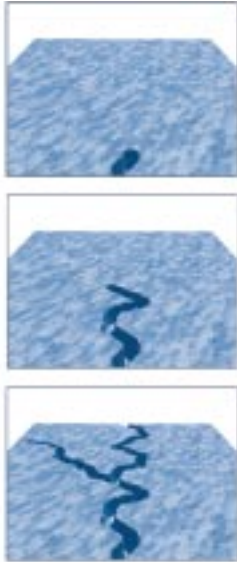

The appearance of cracks in the earth during an earthquake, can be created by animating the geometry of the terrain.

There are several techniques you can use to control how the shape of your terrain changes. You can use the grayscale paintbrush to totally change the geometry of the terrain by adding new peaks and valley, or you can use the Filtering tools to add small changes in elevation to the terrain.

Terrain animations are created using the Animation controls that appear at the bottom of the Terrain Editor.

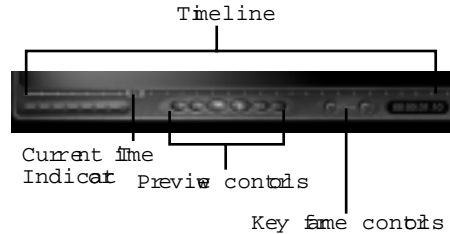

The Animation controls at the bottom of the Terrain Editor lets you move along the Timeline and preview you animation.

The Timeline in the Terrain Editor is the same as the one in the Working window. All the key events recorded for object transformations and material changes are displayed in the Timeline. The Animation controls in the Terrain Editor can perform all the same functions as the those in the Working window. Refer to “Creating Animations” on page 356 for more on using the animation controls.

Animating Terrain Geometry

There are two ways of changing the geometry of a terrain object: by painting directly on the Terrain Canvas or by applying an elevation effect. When you paint on the canvas you create large changes in the terrain like the creation of new mountains or valleys.



The violent motion of great rock columns shooting up from the ground was created by painting a new peak onto an existing terrain at different points along the timeline.



The appearance of foot prints in the sand was created by painting dark footprint shapes in the Terrain Canvas at different points in the Timeline.

When you apply an effect you create smaller more subtle changes like a mountain eroding over time.



The rolling motion in this terrain was created by applying the erode effect at one point in the Timeline and then undoing it in another.

You can also use this technique to record how a terrain object was formed. By adjusting the Current Time as you add elements to the terrain, you'll have a complete record of all your steps.

To animate terrain geometry:

- 1 Click a terrain object.
- 2 Click the E icon that appears next to the terrain object's bounding box. The Terrain Editor appears.
- 3 Click the triangle icon in the Animation controls and make sure Auto-Key is enabled.
- 4 Move the Current Time Indicator to the point in the Timeline where you want the terrain to change.
- 5 Paint new areas in the terrain using the Grayscale paintbrush.
or
Apply one of the effects in the Elevation tab.
- 6 Move the Current Time Indicator to a different point on the Timeline.
- 7 Change the shape of the terrain again using an effect or the paintbrush.
- 8 Continue moving the Current Time Indicator and changing the terrain's shape until you achieve the desired effect.
- 9 Click the OK icon to exit the editor.

Animating Terrain Filtering

By animating the shape of a terrain object's filtering graph you can create some very specific geometry effects.

For example, you can make specific areas of your terrain sink to simulate the damage caused by an earthquake. To create this effect you would darken only areas you want to sink in the Filtering graph. Likewise, you create the effect of ridges forming by lightening specific areas of the graph.

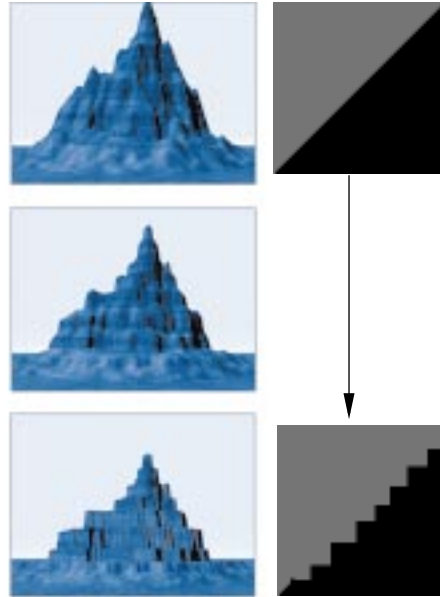

The gradual appearance of stairs in this terrain was created by adjusting the filtering graph at different points in the timeline.

You can also use the Filtering graph to gradually raise or lower the entire terrain over the course of your animation.

To animate terrain filtering:

- 1 Click a terrain object.
- 2 Click the E icon that appears next to the terrain's bounding box. The Terrain Editor appears.
- 3 Click the Filtering tab.

- 4 Click the triangle icon in the Animation controls and make sure Auto-Key is enabled.
- 5 Move the Current Time Indicator to the point in the timeline where you want the terrain to change.
- 6 Adjust the shape of the Filtering graph.
- 7 Move the Current Time Indicator to a different point on the timeline.
- 8 Change the shape of the graph again.
- 9 Continue moving the Current Time Indicator and changing the terrain's graph until you have the desired effect.
- 10 Click the OK icon to exit the editor.

Animating Terrain Clipping

The setting of the Terrain Clipping bracket can also be animated. As areas of the terrain are clipped, they're removed from the terrain object in the scene. Your terrain will look like it's breaking up, or like portions it are falling into the sea.

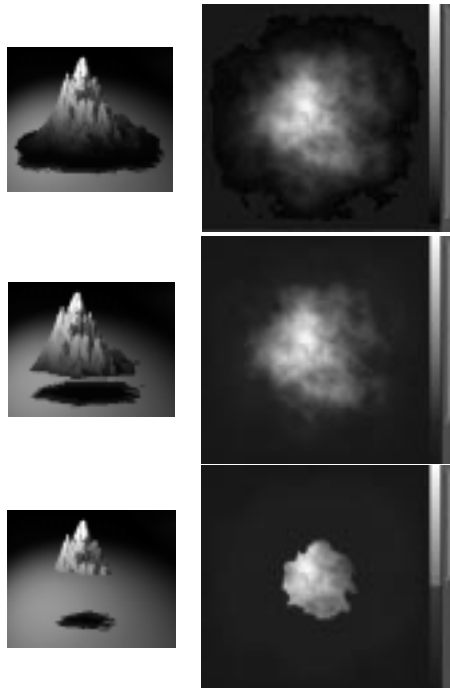

The gradual destruction of this island was created by changing the length of the clipping bracket at different points in the Timeline.

To animate terrain clipping:

- 1 Click a terrain object.
- 2 Click the E icon that appears next to the terrain's bounding box. The Terrain Editor appears.
- 3 Click the triangle icon in the Animation controls and make sure Auto-Key is enabled.
- 4 Move the Current Time Indicator to the point in the Timeline where you want the terrain to change.
- 5 Adjust the width of the clipping bracket.

- 6 Move the Current Time Indicator to a different point on the timeline.
- 7 Change the width of the bracket again.
- 8 Continue moving the Current Time Indicator and changing the width of the bracket until you achieve the desired effect.
- 9 Click the OK icon to exit the editor.

Previewing Terrain Animations

Any change you make to a terrain's properties appear in the 3D Terrain Preview. When you play a terrain animation, the same preview area shows you the transition of the terrain from one key event to the other.

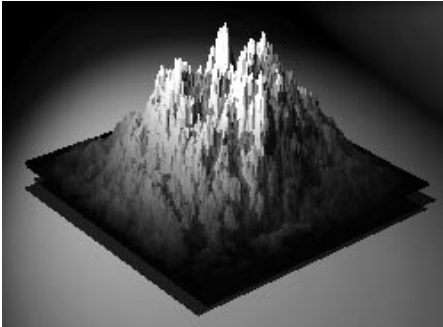

The 3D Terrain Preview displays the preview of your terrain animation.

To preview a material animation:

- Click the Play button in the Animation controls at the bottom of the Terrain Editor.
Click the Stop button to stop the preview.



16

Rendering

What is Rendering?

Rendering is the process of capturing a view of your 3D scene and saving it as a 2D image. Once you've rendered the image, it can be used in other image editing or page-layout applications.

Bryce's rendering process uses multiple passes to generate the final rendered image. On the first pass, the image is rendered in large pixel blocks, and then, in successive passes is refined to produce finer detail. The final pass of the rendering is an AntiAliasing pass.

Using this method you can quickly see how the final image will look. Things like colors and light/object placement are very easy to see even during the first pass or two.



Bryce renders images using multiple passes. On the first pass object placement and color are easily visible...

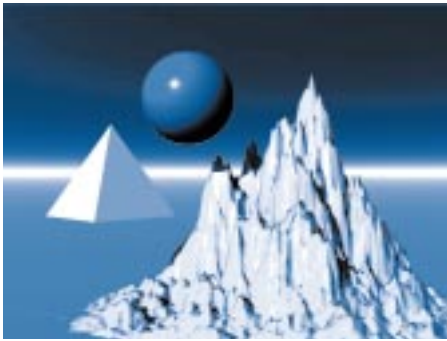

...on successive passes, the image becomes more refined.

Rendering an image requires a great deal of computation. Scenes with multiple terrains (at 512x512 each or more) can generate hundreds of thousands of height points, plus the bump elevations in the textures. This can yield millions of polygons to hit with the rays.

Raytracing

Bryce renders images using a technique known as *Raytracing*. With raytracing, every pixel in an image has a certain color. In the case of a photograph, any given pixel's color is the result

of light coming from a scene, through a lens, and onto the film. Raytracing does the inverse. Virtual rays of light are shot from the virtual "film" through a mathematical "camera" and out into a 3D scene. As they pass through the scene, these rays collide with objects. The object they collide with is assigned a color. For example, if it hits a gray object, then that gray color ends up on that portion of the "film" or your final image.

Raytracing becomes much more complex when the beam strikes an object that has reflective, transparent, refractive, or other complex optical properties. These properties can cause the ray to be traced further into your scene, where it could end up bouncing from mirrors, dissipating through fog, or bending through a chunk of dense glass. Eventually, a final color is determined for each and every pixel, one by one.

This technique can involve staggering amounts of computation which might make it impractical or impossible to use, but Bryce contains raytracing algorithms optimized for the task of creating natural and supernatural landscapes of all kinds.

The Rendering Procedure

Before you render your final image, you'll need to complete the following steps:

- Create and transform the objects in the Working window to create a scene. Refer to "Creating Objects" on page 95 for more on creating objects. Refer to "Transforming Objects" on page 285 for more on transforming objects.
- Add a sky and lights to illuminate your scene. Refer to "Creating Skies" on page 123 for more on creating skies. Refer to "Setting Up Lights" on page 343 for more on creating lights.

- Adjust the position of the camera to get the best view of your scene. Refer to “Positioning the View of Your Scene” on page 332 for more on positioning the camera.
- Set rendering options using the options menu and the Document Setup dialog. Refer to “Setting Render Options” on page 405 for more on setting render options.
- Choose a Render Mode. Refer to “Render Modes” on page 407 for more on choosing rendering options.
- Use the Render Controls to produce a rendered image. Refer to “Using the Render Controls” on page 410 for more on using the Render Controls.

Setting Up a Render

Bryce offers a number of options and controls that let you control rendering.

As you’re working on creating the scene, you should use settings that produce fast renders, but when you’re ready to produce your final image, you’ll want to choose settings that produce the highest quality image.

Setting Render Options

These options let you control the quality and size of the rendered image.

Anti-Aliasing

Anti-Aliasing removes the jaggies on the edges of objects within the image. In Bryce, AntiAliasing is performed using a super-sampling method. This means that for every pixel that’s raytraced, more than one ray is used

to determine the pixel’s color. The increase in rays increases the quality of the raytraced object.

AntiAliasing can greatly improve the quality of your image, but it is time consuming. It can also eliminate some desired roughness from high frequency textures. AntiAliasing is performed on the last pass of the rendering process.

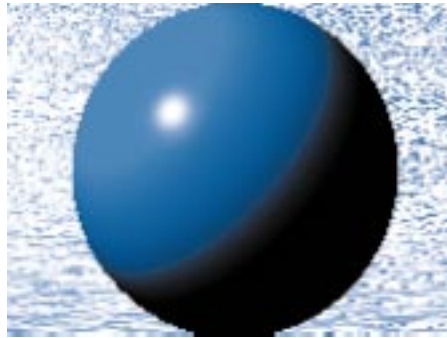

An image rendered without antialiasing...

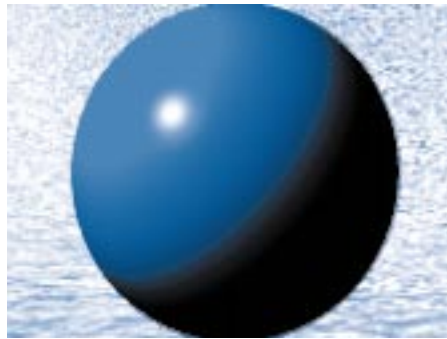

...and the same image rendered using Anti-Aliasing.

There are three Anti-Aliasing modes available in Bryce: AntiAliasing Off, Anti-Aliasing Normal Quality and Anti-Aliasing Fine Art.

Anti-Aliasing Off

In this mode there is no Anti-Aliasing performed on the image.

Anti-Aliasing [Normal Quality]

In this mode after the image is rendered, Bryce scans the entire bitmap to determine which areas require Anti-Aliasing. Only the areas of high concentration are antialiased. In this mode Anti-Aliasing is performed in only the last pass of the rendering process.

Anti-Aliasing Fine Art [Slow]

In this mode, Bryce uses 16 rays to trace every pixel in the image. This produces a higher quality image, but it slows down the entire rendering process from start to finish.

You should probably only use this mode to render showcase type artwork—not normal working images.

To enable Anti-Aliasing:

- Click the triangle icon next to the Render Controls and choose either Normal or Fine Art from the menu.
An option is enabled when a checkmark appears next to its name. Normal antialiasing is enabled by default.

To disable Anti-Aliasing:

- Click the triangle icon next to the Render Controls and choose Anti-Aliasing from the menu again.
The option is disabled when there is no checkmark next to its name. When Anti-Aliasing is disabled, the final rendering pass is not performed.

Render Resolution

The render resolution options control the resolution of your final image. These options do no effect the resolution of your working document: only the final rendered image.

Resolutions are expressed in terms of aspect ratio and pixels.

To choose a render resolution:

- 1 Double-click the Render all control, or choose **File menu > Document Setup**.
- 2 Click one of the render resolutions at bottom of the dialog. The selected resolution appears highlighted.
- 3 Click the checkmark button.

Spatial Optimization

This option changes the number of rays used to raytrace your image depending on the contents of your scene. This option has three modes:

Spatial Optimization Off

This mode is best used for very simple scenes with less than 5 objects. When in this mode, Bryce predetermines the areas where your objects reside and shoots rays only through that area.

Spatial Optimization Low

This is best mode to use for most scenes. In this mode Bryce determines where your objects reside and then go out from there to a larger area to examine the concentration of objects within a larger area. This eliminates the expenditure of unnecessary rays.

Spatial Optimization High

This mode is more extreme version of Spatial Optimization Low. It is best used for complex scenes with localized concentrations of objects. If you have imported DXF objects in your scene, this mode will help speed up rendering considerably.

To use Spatial Optimization:

- Click the triangle icon next to the Render Controls and choose either Spatial Optimization Off, Spatial Optimization Low or Spatial Optimization High from the menu.

48 Bit Dithering

48 bit dithering helps you work around limitations of computer displays. It is a process that allows you to avoid color bands by smoothing. Evening skies or moon rings are good candidates for this option.

Gamma Correction

Gamma correction allows Bryce to compensate for some of the shortcomings of the computer displays. Your images will be brighter and contain more true to nature colors.

Render Reporting

This option, when selected, produces a summary report when your image is finished rendering.

The report tells you how long the render took, including the antialiasing pass. It also provides statistics on how many rays were shot to create the image and breakdowns for the different types of rays, including a per-pixel breakdown.

To produce a render report:

- Click the triangle icon next to the Render Controls and choose Render Reporting from the menu.

Document Resolutions

The menu commands at the end of the Render Options menu are quick ways to resize your document. Values shown are expressed in pixels. For customizing the size and aspect of your document and resulting render.

Render Modes

Bryce offers several rendering modes that let you produce images that can be used to create different effects. For example, the Mask Render mode lets you produce an image that can be used as an alpha channel in other graphics applications.

To choose a Render mode:

- Click the triangle icon next to the Render controls and choose a mode from the menu.

Perspective Render

This mode renders a fully raytraced color image, based on your current camera's position and view.

Mask Render

This mode renders any selected object or objects in as antialiased white shapes against a black background. You can use this image as a mask or alpha channel in other 2D image editing programs.



An example of an image rendered as a mask using Mask Render mode.

360° Panorama

This mode produces an image that looks as if your camera had a 360° lens. The left and right edges of the resulting image join seamlessly.



An example of an image rendered using 360° Panorama Render mode.

This feature is intended for use with the Bryce 360° scrolling screensaver, or Apple's QuickTime VR™ technology. Refer to "QuickTime VR" on page 429 for a description of Apple QuickTime VR.

Rendered 360° images will have little resemblance to the wireframe working window behind it; this makes flipping back and forth between wireframe and bitmap modes during composition fairly difficult. For this reason, we recommend working in standard Perspective Render mode as you compose your image.

For a good 360° panoramic image, you need a natural distribution of objects on all sides of the camera.

Before beginning a 360° panoramic render you should follow these steps:

- 1 Switch to the Top view using the View controls and position objects around the camera while in Perspective Render mode.
- 2 Display the Document Setup dialog using **File menu > Document Setup**, and either select the Panorama preset aspect ratio, or type in the dimensions that you wish.
- 3 Do a quick test render in Perspective Render mode to check composition.
The horizon should be level at the vertical midpoint of your window. If it is not, double-click the Trackball, enter "0" in the Rotate X field and exit the dialog.
- 4 Alter your camera position and Y/Z rotation
- 5 Switch to 360° Panorama render mode and render your image.

Distance Render

This mode results in a grayscale image, with objects represented in shades of gray based upon their distance from the camera. Nearby

objects are black, distant objects are white, and objects in-between are progressive shades of gray.

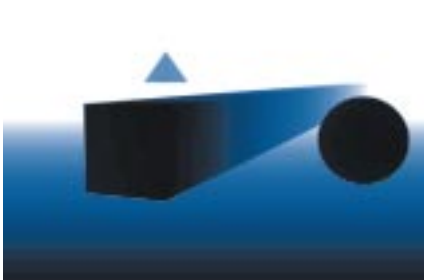
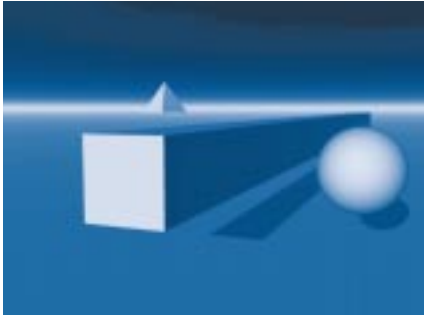

An example of an image rendered using Distance Render mode.



You can use the Distance render image to produce depth-of-field effects using a 2D graphics application.

The purpose of this mode is to produce a distance mask that you can use to create several depth of field effects. Refer to “Adding Depth” on page 421 for more on using Distance Render images.

Altitude Render

This mode results in a grayscale image, with objects represented in shades of gray based upon their height.

You can use Altitude Render images in the same way you can Distance Render images to create special effects in other applications.



An example of an image rendered using Altitude Render mode.

Preview Render Modes

Preview Render modes are accessed using the Render Controls and provide lower quality renders that you can use to preview you image.

Fast Preview

When this mode is enabled, the rendering ignores areas of low frequency and raytraces areas to high frequency only. This results in accelerated renders that are great for previewing during a session. However, it also

results in some patchiness in certain mid-frequency areas, so it should not be used for final output.

To enable Fast Preview Mode:

- 1 Click the Fast Preview button in the Render Controls.

When the button appears depressed, the mode is enabled. When its unpressed, the mode is off.

Textures On/Off

When this mode is enabled, all textural parameters are disabled. This mode performs the following procedures to speed up a rendering:

- Objects with properties like transparency, reflection, and bumpy textures are rendered in flat opaque shades
- Fog, Haze and Clouds are disabled
- Any item with a procedural texture is rendered with a color drawn from the ambient color channel in the Materials Composer
- Any item with a simple color texture is rendered in that color.

The Textures On/Off mode works in any mode.

To enable Textures On/Off Mode:

- 1 Click the Textures On/Off button in the Render Controls.

When the button appears depressed, the mode is enabled. When its unpressed, the mode is off.

Rendering a Scene

Once you've selected any rendering options you want to use and chosen a rendering mode, you're ready to start rendering. You render your entire image using the Render Controls, or, if you've rendered your image at least once, use the Plop Render controls to render areas of your image.

Using the Render Controls

The Render Controls let you start a rendering of your image. There are controls for starting a rendering, resuming a rendering, and starting two types of fast renders.

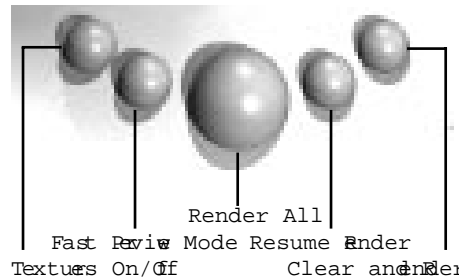

Use the render controls to control the rendering of your scene.

To start a rendering of the entire scene:

- 1 Click the Render All button.

If you have already rendered any portion of your scene, it is cleared before the rendering begins.

You can interrupt any rendering in progress by clicking the mouse.

To resume a rendering:

- Click the Resume Render control or press Command/Ctrl-R.

If you're rendering only a selected area using the Plop Render controls, the rendering resumes only in the selection.

To clear a selection and start a rendering:

- Click the Clear& Render control or press Command/Ctrl+Option/Alt-R.
This control clears the contents of any marqueeed region, and starts a render of the selected region. Refer to plop-rendering below for more on rendering regions.

Plop-Render Mode

If you've rendered your image at least once, you can use the Plop-Render controls to render specific areas of your image. You can use this mode to quickly see the results of repositioning and transformation operations.



Use Plop-Render mode to render specific areas of your image.

Plop-render mode is enabled by default, but can be turned off using the Display palette.

To enable/disable Plop-Render Mode:

- Click the Plop-Render On/Off toggle in the Display palette.



When the small rectangle inside the icon (which represents an active Plop-Renderer) is red, Plop-Render mode is on. When it is white, the mode is off.

To render an area of your scene:

- 1 Make sure Plop-Render mode is enabled.
- 2 Switch to Bitmap display mode by clicking the display mode icon on the right side of the Bryce window.
- 3 Drag a marquee around an area of your image.

The selection is outlined in a thin white line and is separated from the rest of the image by a drop shadow.

- 4 Click the top button that appears beside the selection.

You can interrupt the rendering by clicking the mouse.

To resume a render:

- Click the second button that appears beside the selection.

To scale the selected area to fill the working window:

- 1 Make sure Plop-Render mode is enabled.
- 2 Switch to Bitmap display mode by clicking the display mode icon on the right side of the Bryce window.

- 3 Drag a marquee around an area of your image.

The selection is outlined in a thin white line and is separated from the rest of the image by a drop shadow.

- 4 Click the triangle icon below the render buttons and choose Zoom to Selection from the menu.

The command centers the selected portion of your wireframe scene and scales it up to fit your window. This is a pan & zoom operation, and therefore does not affect your camera position.

RaySpray

You can also paint an area of your scene to render it. Use RaySpray to preview a specific area of your scene. If you render the entire scene after doing a RaySpray render of a specific section, that area will not be re-rendered.

- RaySpray controls include 5 circular and 5 square spray nozzles. While in RaySpray mode, use the 1 through 5 keys to select the circular spray sizes, and the 6 through 0 keys to select the square nozzles.



The RatSpray tool.

To render using RaySpray:

- 1 Click the RaySpray tool on the Advanced Display palette.
- 2 Use the tool to paint over the area of your scene that you want to render.

- 3 Adjust the brush size to more easily paint a larger or smaller area.

You can also render a portion of your wireframe or rendered image to quickly see any modifications made to your scene. You can render from Wireframe mode or from Render mode. RaySpray from Wireframe mode is a preview render that is lost when you press the Escape key.

RaySpray from Render mode is a true render and can be continued by using Resume Render.

To render from Wireframe mode:

- 1 Click the RaySpray tool on the Display palette.
- 2 Click and move the cursor around the wireframe area you want to render.
- 3 Press the RaySpray tool again or press the Escape key to dismiss this render and return to Wireframe mode. This doesn't affect any previous render.

To render from Render Mode:

- 1 Press the Escape key to switch from Wireframe to Render mode.
- 2 Click the RaySpray tool on the Display palette.
- 3 Click and move the cursor around the area you want to render.
- 4 Click the RaySpray tool to put the tool away and remain in render mode. Press Escape again to return to Wireframe mode yet not lose your paint rendered area.
- 5 If you Resume Render your scene, Bryce continues to render the un-rendered portions of your scene.

Rendering a Movie

Rendering an animation is a lot like rendering a still image. Each frame in the animation is processed exactly like a still image. You can use the same rendering options you used to render still images for movies.

Besides the standard still image rendering options, there are several options you can set for movie files: you can choose a file type, a compression option, and a range of frames to render. You set movie rendering options using the Render Movie dialog.

The Render Movie dialog

This dialog contains all the options you'll need to render your scene as a movie.



The Render Movie dialog lets you set options for rendering your scene as a movie file.

Name

This control lets you set a name and location for the rendered movie. The default name and destination is the same as the scene file.

File Type

This control lets you choose the type of movie file you want to produce.

- On the Mac you can render a scene as a QuickTime (MOV) file, or as sequenced frame images.
- On the PC you can render your scene as a MOV, AVI file, or as sequences frame files.

Compression

This menu lets you access all the available compressors. The items listed in this menu depends on the compressors you have on your system. Refer to the documentation that came with the compressor or your system software for instructions on using a specific compressor.

Render Range

These options let you choose a range of frames to render as the final movie. You can choose to render all the frames in your animation, a specific range of frames, or only the frames within the Working Area of your animations timeline. Refer to “Setting Up the Working Area” on page 360 for more on the Working Area.

To start the rendering of a movie:

- 1 Choose **File> Render Movie**. The Render Movie dialog appears.
- 2 Enter destination and name for the movie.
- 3 Choose a file format for the movie.
- 4 Choose a compression option from the menu.
- 5 Enable a render range option.

If you choose Frames, enter a start and end frame number for the range.

- 6 Click the OK icon. Bryce starts rendering each frame in the movie.

Batch Rendering

Batch Rendering lets you render a number of files at the same time. This way, instead of rendering each scene as you create it, you can set up a number of scenes, save them and then render them all at once at a convenient time

To perform a batch render:

- 1 Save a number of scenes to a folder.
- 2 Drag all the files on the Bryce application.
Bryce opens the file, renders it, saves it and then opens and renders the next file. You can render any number of files this way.

Fast Render Strategies

There are several techniques you can use to speed up the rendering process. These techniques are most useful when rendering animations, where you may have a large number of images to render.

You can greatly increase the speed of a render just by using the Preview Render modes. Below is a table showing the time it takes to a render a scene, containing complex materials and lights, using normal rendering and then using the preview modes.

Render Option	% of standard time
Full Render	100%
Fast Render	41.7%
Textures Off	35.4%
Fast Render w/ Textures Off	8.3%
Fast, Textures Off, AntiAliasing Off	2.1%

Patch Rendering

Using the Plop-Render mode, you can do a patch render of image. Patch rendering involves the rendering of background and flat elements using normal rendering and then using the Plop-Render controls to render areas that contain more complex elements.

There are two thing you should remember when using patch rendering:

- Make sure you use Clear & Render when you make changes with a partially rendered image. If you stop a rendering, make changes and then click Resume Render, you'll end up with noise instead of an image.
- If you changed elements that don't affect a large area of your scene, you don't have to render the entire scene again. For example, if you render a scene with a floating sphere, and then delete it, you don't need to re-render the scene, only the area where the sphere was.

To patch render your image:

- 1 Start a render as normal.
- 2 Let the rendering proceed for two or three passes and then click the mouse.

- 3 Switch to Bitmap display mode.
- 4 Drag a marquee around key portions of your scene and then render those areas using the Plop-Render controls.

You can also speed up rendering using these techniques:

- Limit the number of lights.
- Keep objects near the background simple.
- Limit the number of volume materials you apply.
- Limit the number of transparent and reflective objects.
- Limit the number of frames per second to 15, which is adequate for QuickTime movies. Video uses 30 fps and film 24 fps.
- Divide animations into smaller files and eliminate objects that won't be seen on-screen.
- Turn off AntiAliasing when previewing animations.

Working with Rendered Images

Once your scene is rendered, it becomes a 2D image that you can save as different formats and edit in other 2D image applications.

In Bryce, the 2D image is used as the Bitmap display mode. You can use the bitmap as guide for move objects, or as a preview of your final image.

Scaling Your Image

The Pan and Zoom tools work independently in wireframe display mode and in bitmap display mode. So if you use the Zoom tool to scale your wireframe scene down, your rendered image remains unchanged.

You can then use the same tools and commands to scale your rendered image up or down, independent of the scale of your wireframe scene. If the image is scaled up sufficiently, you can use the Pan tool to pan through the enlarged image.

Refer to “Panning” on page 27 and “Zooming In and Out” on page 26 for more on the Pan and Zoom tools.



17

Using Bryce with Other Applications

Overview

This chapter describes how Bryce works with other applications, the file formats that Bryce supports for both import and export, how to use Bryce to create web-based applications, and how you can communicate with other Bryce users on the web.

The effects you add to a rendered image are considered post production. Post production includes things like compositing, filtering and retouching the image in an image-editing application. Post-production can also include exporting to other applications. These aspects of post production are also covered in this chapter.

When you're working with animations, post production can include all of the still image operations, or it can include more advanced editing, like combining clips and adding sound effects.

Working with Other Applications

Bryce allows you to import images and objects from other applications. You can also export images and objects to many of those same file formats. To learn more about the file formats listed here, refer to the MetaCreations web site for details.

Importing Images

Choose **File menu > Open Image** and select from one of the following image types:

- Bitmap (.bmp)
- Enhanced Metafile (.emf)
- Flashpix (.fpx)
- CompuServe GIF (.gif)
- JPEG (.jpg)
- Photoshop (.psd)
- Targa (.tga)
- TIFF (.tif)
- PICT (Mac only)

Exporting Images

You can export all of the formats listed above except for the Enhanced Metafile format.

Use one of the following commands to export files. If you need to conserve memory or plan to create a QTVR Panorama movie, you'll want to use the Render to Disk option.

- Choose **File menu > Save As**, then select a file type from the list. Not all file types are supported.
- Choose **File menu > Export Image**, then select a file type from the list. Bryce uses

plug-in filters for both the Export Image and Render to Disk options.

- Choose **File menu > Render to Disk**. This is the best choice if you have created a very large image, because it lets you set the dpi resolution and saves memory.

Export Image and Render to Disk allow you to export the following additional formats:

- HTML pages (.htm)
- QTVR Panorama Movies (.mov)

To learn more about QTVR, see "QuickTime VR Panorama Movies" on page 425.

Importing and Exporting Objects

Bryce can import objects created in the following file formats. To learn more details about importing and exporting these file formats, check the MetaCreations web site.

- **TrueSpace** (.COB) Versions up to 4.0 are supported. Material properties are supported.
- **VideoScape** (.VSA) All versions are fully supported.
- **VRML1** (.WRL) Imports all properties relevant to Bryce, including camera, light, and surface and material textures.
- **LightWave** (.LWO or .LWS) Both objects and scenes are supported. The camera, lights, and all objects (with material information) are imported.
- **Heightfield** (.HF) Used to import descriptions of heightfields (terrains).
- **USGS DEM** (.DEM) All forms of DEM files are supported.

- **USGS SDTS** (.DDF) This format is the new USGS format which will replace DEM files.
- **Portable Greyscale Map** (.PGM) Used to import descriptions of heightfields (terrains).

Bryce can export your final rendered object to the file formats listed below. The information includes vertices, smoothed normals, UVs (texture coordinates), and the texture maps.

Some of the formats have their own limitations. For example, DXF doesn't support smooth normals or UVs. If the file format doesn't support texture embedding, each texture map is written as a separate image at the same location specified for the mesh file. The names of the images will start with the name you specified for the mesh file and include the name of the material. If UV information can't be written, two texture maps are exported: one for the top part, and one for the bottom.

When you export to a 2D format such as DEM or PGM, all the possible texture maps are generated.

- RayDream Studio (.RDS)
- USGS DEM (.DEM)
- AutoCAD (.DXF)
- Portable Greyscale Map (.PGM)
- VRML1 (.WRL)
- Heightfield (.HF)
- Infini-D 4.0 (.ID4)
- LightWave (.LWO or.LWS)
- Wavefront (.OBJ)

To export an image:

- 1 Render your scene.

- 2 Choose **File menu > Export Image**. The export dialog appears.
- 3 Choose a format for your image and click OK.

Post Production

Bryce is a 3D application that creates landscapes, it is not an image-editing program. As such, you won't find any useful image-enhancing capabilities you'll find in an image editor. For post production operations you'll need to use applications like Painter[®], Corel PHOTO-PAINT[®] or Adobe Photoshop[®]. You can use these applications to adjust colors, contrast or brightness. You can even paint in elements that were not in the original scene.

Bryce's rendered images can be saved in formats compatible with almost any image-editing application.

Compositing

Compositing is the process of pasting one image into another. For example, if you create a farm scene in Bryce and then create a mask for that scene, you could paste it into a scanned image of a tornado. With a little creativity you can make the farm appear as though it were about to be eaten by the storm.

The shape of the foreground image is taken from a black and white image that contains the shape of your scene. This image is called a mask. You can generate a mask in Bryce by using the Mask Render mode.



Using compositing, you can take the scene you created in Bryce....



...render it as a mask, using Mask Render mode...



...and then use the image as a selection mask in a 2D image-editor. Once selected, you can place your Bryce scene into a scanned image.

To render a scene as a mask:

- 1 Click the triangle next to the Render controls and choose Mask Render from the menu.
- 2 Choose **File menu> Export** and choose either BMP/PICT.

Using Painter

The following compositing procedure uses Painter as a post production application. The steps for Adobe Photoshop would be almost the same.

To composite using Painter:

- 1 Render the scene normally using Perspective Render mode.
- 2 Save the image in a convenient location.
- 3 Render the scene again, this time using Mask Render mode.
- 4 Save the mask image to the same location.
- 5 Open the Perspective Render image in Painter (or another image-editing application).
- 6 Choose **Select menu> Load Selection**.
- 7 In the dialog, select the Mask Render image. Click OK.
Painter selects the objects in your scene.
- 8 Choose **Edit menu> Copy**.
- 9 Open the background image (the image you want to paste your Bryce scene into.)
- 10 Choose **Edit menu> Paste**.
The selection is pasted into the image as a floater.
- 11 Position the floater where you want it.

Refer to the documentation that came with your image-editing application for more information on working with masks.

Adding Depth

Bryce's Distance Render produces an image that can be used as a distance mask in most image-editing applications. The Distance Render image contains grayscale representations of all the images in your scene. Objects closer to the camera appear black, while those furthest away appear white. The objects in between are various shades of gray depending on their distance from the camera.

This grayscale information can be used to create photographic depth of field effects. For example, if you take an image that has a lighthouse in the foreground and a fishing village in the background and render it using Distance render mode, you can take the image into Adobe Photoshop® and create an image where the lighthouse is in sharp focus while the village is blurred.



You can add depth to your scene by taking a scene you created in Bryce....



...rendering it as a distance mask, using Distance Render mode...



and using an image-editing application to place the distance mask into the original image's alpha channel. Once the Distance render is in the alpha channel you can apply filters to create photographic depth of field.

To render a scene as a distance mask:

- 1 Click the triangle next to the Render controls and choose Distance Render from the menu.
- 2 Choose **File menu> Export** and choose PICT.

Using Photoshop

The following procedure uses Adobe Photoshop® as a post production application. The steps for Painter would be almost the same.

To create depth of field using Photoshop:

- 1 Render the scene normally using Perspective Render mode.
- 2 Save the image in a convenient location.
- 3 Render the scene again, this time using Mask Render mode.
- 4 Save the mask image to the same location.
- 5 Open the Perspective Render image and the Distance Render in Photoshop.
- 6 Place the Distance Render image into the alpha channel of the Perspective image.
- 7 Load the alpha channel as a selection.
- 8 Apply Gaussian Blur.

Objects close to you will appear sharp while objects farther away will become progressively more out of focus.

- You can also invert the selection and apply Motion Blur to the image. In this case, objects in the foreground would be motion blurred, and the background would be sharp, as if you took a picture from a moving car.
- If you take the Distance Rendered alpha channel and, in Photoshop's Curves dialog, remap the gray values, you could determine very specifically which objects in your scene are in focus and which are not. Just remap black

input to lighter output, and the gray value of the desired focal object to black.



You can change the focus of images by remapping the gray values in the alpha channel of your image.

Printing Images

You can print rendered images directly from Bryce. If you need color separations, you'll have to use an image-editing or pre-press application.

You can specify printing options such as print quality, number of copies, print grayscale, image type (vector wireframe or rendered image), printer driver or postscript, as well as printer options such as intensity, halftoning, bleed control, and color matching. You can also preview a job before sending it to the printer.

To print an image:

- 1 Choose **File menu**> **Print**, or press Command-P/Ctrl+P. The print dialog appears.
- 2 Choose the options you want to use.
- 3 You can select any of the four optional drivers or print either your rendered image or your wireframe document.

Using Bryce on the Web

If your computer is connected to the Internet, you can access the Internet while using *Bryce 4*. You can talk with other Bryce users, visit the MetaCreations site, or view the latest technical support information.

Internet Connection

You must have an Internet connection and a browser package to use the web-based features of Bryce. If you have an account with an ISP (Internet service provider), such as EarthLink, AOL, or other provider, you are ready to go. Otherwise, you will need an Internet account with a provider, as well as a modem hooked to a phone line. Once you have a connection, you can start using Bryce's Internet-based features such as BryceTalk.

If you have an e-mail only account with a provider such as Juno, you will not be able to use all of the web-based features of Bryce.

Using a Browser

The two most common browsers are Internet Explorer and Netscape Navigator. It is highly recommended that version 4.0 or greater be used for either browser, in order to take advantage of interactive HTML features.

PC Users

If your computer is running Windows 95, Windows 98, or Windows NT 4.0 or later, you should already have Internet Explorer installed. If not, you'll need to install it. Once you have an account with an ISP, you can start using the web-based features of Bryce.

Macintosh Users

Once you have an account with an Internet provider, and a browser software package installed, you can start using the Internet-based features of Bryce.

Accessing the Web

Bryce now has a "Links" menu that will launch your default browser and take you to the one of the Bryce-related web links in your links list. You can update this links list to add your own links and delete any default links you may not need to use.

In addition, you can also export both still files to the web using the Export Image or Render to Disk options on the File menu. You can export animations through the Render Animation feature.

To select a web link:

- 1 Go to the Links Menu.
- 2 Click a web link.
- 3 Bryce communicates with your browser to access the desired link.

Modifying a Web Links Menu

You can modify your web links menu using a text editor to edit the file called: Bryce 4 Links. It is a simple ASCII file that contains one line per link. Each line contains the name of the link, surrounded by quotes, a separating comma, and the url in quotes.

To add or delete web links

- 1 Open a text editor, such as WordPad, Note Pad, or SimpleText.
- 2 Find the file entitled “Bryce 4 Links.”
Note that each line of the file contains the name of the link, in quotes, followed by the url, also in quotes.
- 3 Delete the entire line for any links you want to remove from your list.
- 4 Enter the name of any new link, a comma, and any amount of space, followed by the url of the new link in quotes.
- 5 If you want to add a dividing line to your menu, place an underline in quotes in both the link label and url.
- 6 Save the file.

Your menu should now reflect your new links.

Create HTML Images

Use Bryce to get your Bryce images on the web! Bryce will export an HTML page with your rendered image, along with any hotspot links associated with the objects in your Bryce scene.

With the HTML dialog, you can set your web page title, the server directory for the page (either your local hard disk for editing or the web site it is going on directly), the name of the JPEG file for the image, your e-mail address, and the Background URL (leave this blank if you wish to not have one).

Also, in the dialog are two slider settings you can adjust—one for the level of JPEG compression, and the other for how precise you wish the hotspot polygons to be. Bryce will then generate the HTML page and the JPEG image file for you, ready to be brought straight onto the web.

To create an HTML page:

- 1 Edit the attributes of the objects in the scene you want to be hotspot links.
- 2 Select the Linking Tab, and enter the URL into the web Link box.
- 3 Select all the objects in the scene to be hotspot links.
- 4 Render the scene.
- 5 Select either **File menu->Export Image** or **>Render To Disk**
- 6 Select HTML files (.htm) as the type of file to export/render to disk and name the file.
- 7 Fill in the settings in the HTML dialog.

Your image is exported in JPEG format.

Realmovie Animations

The RealMovie format is a new way of viewing streamable movies through the internet. Bryce RealMovie (.RM) movies are streamable using any possible throughput, so they are ready to go with RealMovie servers.

To create a RealMovie animation:

- 1 Create an animation in Bryce.
- 2 Select **File menu > Render Animation**.
- 3 Select RealMovie as the Output Module Format.
- 4 Set the filename to save as and go!

QuickTime Movies

Bryce creates pre-flattened QuickTime moves that are ready to go wherever you wish to take them, be it the internet or your friend's computer.

To create a QuickTime movie:

- 1 Create an animation in Bryce.
- 2 Select **File menu > Render Animation.**
- 3 Select QuickTime Movie.
- 4 Click Edit to adjust the details of the animation.
- 5 Set the filename to Save As and go!

QuickTime VR Panorama Movies

Bryce can now generate QuickTime VR Panorama Movies directly. Panorama movies are movies from which you can interactively swing your viewing angle around 360 degrees.

This type of movie is created from a single 360 degree Panorama image. You can generate a QTVR movie from Export Image or Render To Disk. For it to look right, you must follow all the setup steps as described in “QuickTime VR” on page 429. Briefly, you must:

- Change the aspect ratio of the document to 13:4 by clicking the “QTVR Panorama” option in the Document Setup dialog.
- Select 360 Panorama in the options given by clicking on the triangle next to the render controls.

When you use Render To Disk, you can optionally select 90deg counterclockwise rotation for QTVR, to save memory.

Using BryceTalk

Using BryceTalk, you can do the following:

- Set up your BryceTalk account
- Start or end a BryceTalk session
- Change rooms, start a new room, or close a room
- Participate in discussions in multiple rooms

Communicating with Bryce Users

While using Bryce, you can communicate with other Bryce users. (Using BryceTalk you can exchange messages with other people in real time. This means that you could be typing messages from Chicago to someone who is still awake in Paris.) However, you must be a registered Bryce user in order to send and receive messages. If you haven't registered already, this is an excellent time to do so.

You can ask questions, share ideas and tips about using Bryce, and meet other Bryce users. Who knows, you may find your long lost Uncle John communicating here.



A BryceTalk session.

Setting up BryceTalk

The first time you use BryceTalk, you need to register and set up your BryceTalk account. After that, you can sign on, using your nickname and password, then start communicating with a focused community of other *Bryce 4* users.

To set up BryceTalk:

- 1 From anywhere within Bryce, click the Talk text button to start the BryceTalk application. If this is the first time using BryceTalk, select the New Account button.
- 2 Follow the instructions on the web page to set up your BryceTalk account.

- 3 Provide your name and serial number when requested.
- 4 Select a nickname. This is the name that other users will see when you are signed on.
- 5 Select a password that you will remember.
- 6 Once you have finished setting up BryceTalk, you can go back to the sign on screen and open BryceTalk for the first time.

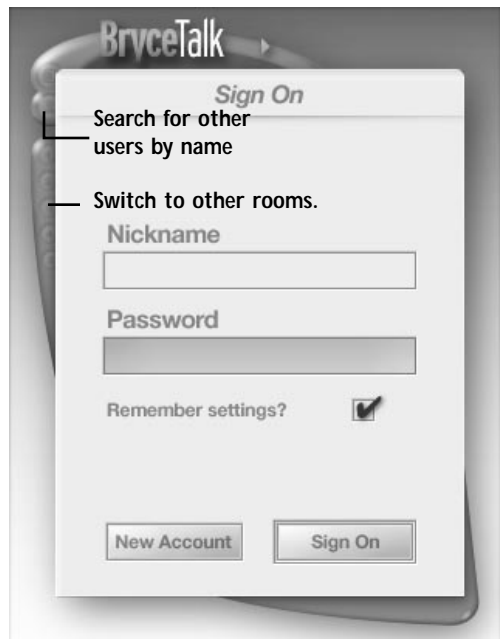

The login screen.

To start a BryceTalk session:

- 1 From anywhere within Bryce, click the Talk text button.
- 2 Type your nickname and password when prompted. You are placed in the BryceTalk Lobby. A welcome message tells you which

other Bryce users are currently communicating in that room.

- 3 You can communicate in the BryceTalk Lobby, go to other rooms, or start a new room.

To restore a BryceTalk session:

- 1 Click anywhere in the Bryce window to return to Bryce, or press Shift+T.
- 2 Click Talk again to restore the BryceTalk session.

To end a BryceTalk session:

- 1 If desired, tell the other users good-bye.
- 2 Press Cmd+Q (Macintosh) or Ctrl+Q or Alt+F4 (Windows).

Communicating with Other Bryce Users

You can join any conversation in any room. You'll notice that a conversation looks like a movie script, so it is easy to tell who is talking. Use the scroll bar to review any part of the conversation once it gets too long to fit in the window. Other Bryce users may be communicating in the BryceTalk Lobby, or they may have started a separate room to discuss a specific subject.

At any time, you can find out who is logged on, search for a friend's nickname, join discussions in other rooms, or start your own discussion room. Unlike being at a real party, you can even participate in discussions in several rooms at once!

To communicate with other users:

- 1 Type your message in the lower section of the BryceTalk window. You can edit your message until you are satisfied with the results.
- 2 Press Enter to send your message once you have finished composing.

To find out who is logged on:

- Click the People icon, and a list of the users in that room is displayed.

To search for a nickname:

- 1 Click the People icon to display the list of nicknames.
- 2 Click the Search button and type the nickname you are seeking.

To change rooms, you can:

- Click the room buttons to go to different rooms.
- In the room list, double-click the room to which you want to go.
- Press Ctrl+Tab to cycle through the rooms you are in.

A highlighted room button indicates that activity has happened in a particular room since you last looked at it. When you see a highlighted room button, you can go back to that room to view the discussion. As you switch rooms, you participate in each room. You can also close any room (on your computer) by clicking the close window control.

- Be respectful. Avoid offensive language or subject matter. This is a public forum and users of any age may be listening.
- Be discreet. Don't reveal intimate information about yourself over the Internet. As you would in any public place, be reserved with strangers.

To start a new room:

- 1 Click the New Room button in the room list to create a new room.
- 2 Type a meaningful title for your room such as "creating natural sunsets." You can use up to 32 characters including spaces and punctuation in your room title.
- 3 Press Return or
- 4 Enter, and you are placed in your new room.

Other users will see a new room added to their list and can choose to join it.

Tips: If you are new to using the Internet, these tips will help you get started:

- Don't type in all capital letters. Use upper and lower case. Typing in all caps is considered yelling.
- If you are uncertain how to proceed, try lurking. Listen without posting a question or responding. Sometimes someone else will ask your question. This is a good way to get used to the BryceTalk room and to learn how to interact with others on the Internet.
- Have fun! This is a communication forum for you, a Bryce user. You'll meet other fun people like yourself.



A

QuickTime VR

QuickTime VR allows you to take a 360° panoramic image, and make it into a VR Movie; this unique movie will translate the 2D panoramic representation of your 3D world, and allow point and click navigation through the world. You can look up, down and around your rendered scene as though you were a camera on a tripod.

Further, QuickTime VR lets you create “Nodes,” or hotspots in the movie where you can click and go to another linked movie. This means you can look around a landscape, and seeing an interesting rock formation in the distance, click on it to view the entire landscape from that new vantage point.

These nodes can also contain “Object Movies;” another specialized technology from Apple that allows you to click and drag to, in effect, “pick up” any object in the VR movie and examine it from all sides, as if you literally picked it up and turned it around and around in your hands.

Creating QuickTime VR Panoramas

The process of creating a panorama involves completing a few easy steps.

To create QuickTime VR panoramas:

- 1 Choose Default in the Document Setup dialog.
- 2 Click on the uppermost Views Memory Dot in the control palette, to make sure your camera is level.
- 3 Set up your scene.
The important thing to remember is that for a successful 360° scene, you need interesting objects all around your camera. The best way to work on this is to go to the Top View, and position objects all the way around the camera.
- 4 Keep the Nano-Preview in Camera View mode to check your view while you are working in Top View.
- 5 Drag the tip of the camera around in the Working Window to check the scene the view of your scene from all directions.
- 6 Switch back to Camera View and do a quick test render, once you have a good distribution of objects in a visually interesting scene.
- 7 After the render, make any required position changes.
- 8 Choose **File > Document Setup** and select QTVR Panorama.
This aspect ratio is optimized for use with Apple's Make QTVR Panorama tool, though many aspects will work.
The preferred aspect is 13:4. Width must be divisible by 96, and height must be

divisible by 4. The QTVR Panorama option makes sure your image meets these criteria.

- 9 Click the triangle icon next to the Render controls and choose Select 360° Panorama from the menu.
- 10 Click the Render button to do a quick test render.

The panoramic render mode necessarily introduces some distortion into your image, and this may change the way you want your objects to appear.

- 11 Make any position changes you like.

When you do a panoramic render, your wire-frame scene will bear little resemblance to the rendered scene. This is why you should work on your scene in standard Default mode, and switching to Panoramic rendering after everything is set up.

- 12 Choose **File menu > Render To Disk**. The Render to Disk dialog appears.
- 13 Leave the default settings.

The Output Size in Pixels was set by the QTVR Panorama option in the Document Setup dialog.

The Print Resolution defaults to 72dpi, which is the only acceptable setting for the screen-resolution VR movies; and the Output Size in Inches is extra information. You can, however, use these features to your benefit if you need to print out a 2D version of your VR scene.

- 14 Click the OK icon.
- 15 In the Save dialog, choose QuickTime VR, then click the Save button.
- 16 Specify the location and file name for your rendered QuickTime VR panorama.

To export a QuickTime VR Panorama:

- 1 Follow the steps above through step 11.
- 2 Click the Render button if you made any changes after your test render.
- 3 When the rendering is done, choose **File menu > Export Image** and choose QuickTime VR from the list.
- 4 Specify a location for the saved panorama, then click Save.

Further VR Exploration

This is a quick way to get started with simple, single-node QTVR movie-making. To create movies with other embedded nodes, or to get deeper into the world of QuickTime VR, contact Apple Computer via the World Wide Web or any normal channel, and ask them for further information.



B

Glossary

2D projection Your 3D scene must be interpreted as a 2D projection; that's how it is translated to your 2D screen! Pretend your 3D scene is a drawing on a (2D) piece of paper, which is in front of your camera lens; you have control over the right/left up/down position of the paper (Pan controls), and over the scale of the drawing (Zoom/Scale tools). 2D Projection values are an important factor in defining a View for your scene.

3D transformation This is a term that refers to any operation relating to the size, rotation, and position of any object. There are in fact other types of 3D transformations that are possible in 3D space, such as deformations, sweeps, and lathing; but Bryce is not a modeler, and supports only the basic three: size, rotation, and position.

3DMF Apple's 3D MetaFile format for exchanging 3D geometry between applications.

absolute coordinates Values which express an absolute location, rotation, or size, whether they are location coordinates, degrees of rotation, or units of measure.

additive mode A color blending algorithm which adds the brightness value of colors from one item to the brightness values of another.

algorithm A finite step-by-step problem-solving procedure.

aliasing A visual artifact caused by low resolution sampling that can cause hard edges or areas of high frequency in an image to look jagged (often referred to as “jaggies”). See “anti-aliasing.”

alpha channel A separate grayscale channel accompanying any PICT/BMP file that can determine which areas of the PICT/BMP will be visible in the final image and which will not. Typically, white areas in the alpha channel describe the areas in the corresponding image that will be visible, while black areas in the alpha channel describe the areas in the corresponding image that will not be visible. Also referred to as a mask. In the absence of an alpha channel, Bryce can use the luminance values of any 2D PICT or 3D solid texture as alpha information.

altitude A measurement of height. In Bryce, many textures will change their behavior based on altitude.

ambient Light that has no point of origin or specific direction, and is presumed to strike every point on every object with equal intensity. Since it is not affected by other environmental light, it tends to affect objects in shadow, and can make objects visible even with no specific light source.

amplitude In Bryce, this refers to the intensity of the cloud definition. Increasing the amplitude will make cloud contours harder, while decreasing it will result in softer-edged, more diffuse cloud formations.

antialiasing The process of eliminating aliasing by higher resolution sampling, so that hard but jagged edges appear smooth and clean.

aspect ratio The relationship between the width and height of your document, expressed in pixels as a width to height ratio.

auto-update A feature in Bryce’s Sky & Fog palette and Nano-preview which will automatically update your changes into your rendered scene or Nano-preview, respectively.

banking Camera rotation around its Z axis; kind of a left/right tilt. Also known as roll, it creates the illusion that your horizon is tilted.

batch rendering A process that will allow you to automate the rendering of multiple scenes. Just drag and drop a group of scene files on the Bryce application icon, and Bryce will do the rest.

bitmap Literally, a “map of bits.” Your screen is comprised of pixels, and each one of those pixels expresses a level of color, whether it is one bit (black and white) or 24-bit (millions of colors). Your image, when rendered, can be thought of as a pixel-by-pixel map of color, hence the term “Bitmap”.

boolean rendering A rendering process wherein either the space taken up by “negative” objects is subtracted from “positive” objects, yielding an object with portions removed; or two or more objects are combined to form a composite object combining the mass and dimensions of all contributing objects.

boolean A fancy word that is used to describe a system where there are two possible states: On/Off, Yes/No, 0/1, True/False, and so on. With respect to Bryce rendering, a Boolean attribute such as Negative or Intersect will determine whether a particular part of a group of objects will be Rendered/Not Rendered.

bryce units of measure An arbitrary system of measurement for 3D objects in Bryce 3D. Most Bryce objects when they are created are a default size of 2048x2048x2048 Bryce units.

bump mapping A process that interprets changes in an object's surface luminance or color values and, without actually affecting the object's geometry, expresses them as perturbations on the object's surface.

camera space A method for representing objects in 3D space. It uses a set of Cartesian coordinates which are relative to your camera.

camera A metaphorical "tool" for viewing areas in a scene. The metaphor refers to the conical projection of the scene onto a 2 dimensional plane along a specific direction.

center scaling The ability to perform resizing or rotating operations on an object based on the object's center, rather than an alternate point, such as its base.

CMYK color A well known subtractive color standard widely used in the print industry. CMY color models blend Cyan, Magenta, and Yellow to approximate colors for print; almost always used with a fourth ink, black (K), to compensate for ink impurities.

conversion The process of changing an object of one type into an object of another type. Use the little arrow in the Edit palette...

deformation A special form of 3D transformation which will deform an object's geometry, creating bulges, twists, bends, and more. Bryce 3D does not support this kind of transformation; but you can certainly import deformed objects from other modeling applications via Bryce's Import DXF and 3DMF feature.

depth cueing The effect we use to create the appearance that wireframes far away are dim-

mer than wireframes closer to the camera. This effect is adjustable.

derivative objects Most primitives available in the Create palette also have a few derivative objects as well. For instance, the Sphere is accompanied by an Ellipsoid and a Squashed Sphere; both are considered to be Spheres by Bryce, but they have had some post-processing applied to change their sizes.

diffuse Light that is evenly reflected from an object's surface, visible regardless of the angle from which it is viewed. Diffuse is associated with matte objects.

document resolution The actual size of your working document area, expressed in pixels. When your Render Resolution is set to 1:1, the Render resolution is the same.

DXF Originally developed for use with AutoCad™, this is the most common 3D file exchange format.

edit Any action performed on an object after its initial creation. Includes moving, resizing, rotating, copying, assigning textures, pasting, and more.

family A kind of logical association, assigning a Family attribute to a set of objects allows you to select and display sets of objects based on an assignable wireframe color and associated family name. This way, objects which share some characteristic such as distance, structure, material, or other, can be easily seen, selected, soloed, and so on.

field of view Field of View values describe the range, from 1 to 180°, which your camera is allowed to take in.

frequency A measurement of the number of times certain textural characteristics repeat themselves within a fixed area.

gel A texture or picture which is applied to a light and treated as a transparency or slide, enabling the light to project colors, textures, or images onto objects in your scene.

grayscale-to-height mapping A process that interprets a grayscale range from black to white and expresses that range as height, from low to high.

group Grouping, a kind of spatial association, allows a set of objects to be treated as one. To achieve Boolean rendering effects, objects must be grouped.

HLS color An alternative color model: Hue, Lightness, and Saturation.

HSV color An alternative color model: Hue, Saturation, and Value.

illumination In Bryce 3D, any property or characteristic related to how an object responds to light. This includes Ambient, Color, Diffuse, Reflectivity, Refraction, Specular, and Transmissivity.

image resolution Since Bryce renders bitmaps at 72dpi, the only image resolution you need to determine is the height to width ratio of your image.

infinite plane A two dimensional surface that extends infinitely along the X and Z axes. Bryce 3D's Ground, Cloud, and Water Planes are all infinite planes, though they exhibit different textural properties and are placed in the scene at different altitudes.

landing Dropping an object straight down onto the object directly beneath it. Usually used to "land" an object on the ground.

link to view A Bryce feature which locks the sun's position to the camera position. This way you can use the sun control to set your sun

position, and you will not lose that position if you move the camera.

location An object's position in 3D space. Synonymous with position and offset.

mapping The process of interpreting data input of one kind and expressing it as another. See Bump Mapping, Grayscale-To-Height Mapping, Pict Mapping, and Texture Mapping.

marquee selection Marquee is a noun which refers to a tool, in many applications, which will create a selection area; it can also be used to refer to the selection itself. Bryce has no marquee tool per se, but you can click and drag in the wireframe window to marquee a selection (here the term is used as a verb), and you can click and drag in the rendered image to marquee a selection for discrete rendering.

material In Bryce 3D, the sum of up to four textural elements, either 3D procedural or 2D picture-based, used to drive various effect channels, plus post processing, used as a surface property for Bryce objects.

materials channel The rows in the Materials Grid, grouped as Light, Effect, and Color; can be driven independently or by Texture Components.

materials grid The gameboard-like area in the Materials Lab where Texture Components drive parameters in the various Channels in the Grid to make a Material.

matrix The term is used only in the Bryce Edit menu, for the Copy/Paste Matrix commands. When you use these commands, you are copying and pasting an object's position, rotation, and size; you are not copying size, rotation, or position alone, but the matrix of all coordinates, hence the name.

memory dots A feature created by MetaCreations, and used in many MetaCreations products, it is available in the Control palette for use with Views, and in the Sky & Fog palette. This feature allows you to simply click on a Memory Dot to save the state of the parameters to which it pertains.

mesh Sometimes known as polyhedron. Used in reference to imported geometry as well as Bryce's internally created Stone objects. Similar to Polygon, but polygonal faces have been diagonally split, or triangulated.

nano-editor The Nano Editor is a small version of your wireframe window, which you can use to edit your scene quickly.

nano-preview A small preview of an object or scene. The Nano-preview window is at the top of the Control Palette.

object space A method for representing objects in 3D space. It uses a set of Cartesian coordinates which are relative to a given object.

object type Though Bryce creates and imports many kinds of objects, for the purpose of selections and conversions it must sort these objects into types. These types can be clearly seen in the Conversion option and in the Edit palette. Cubes and their derivatives are all of the Cube type; Cloud, Water, and Ground planes are all of the Infinite Plane type; Pict objects and 2D Faces are all of the 2D Face type; all imported objects are of the mesh type.

offset An object's position in 3D space. Synonymous with position and location.

opacity The degree to which light cannot pass through an object. In Bryce, the term primarily refers to the opaque portions of alpha-channels.

orientation An object's orientation in 3D space, expressed in degrees; synonymous with rotation.

orthogonal A special projection of your scene which has no perspective distortion. Kind of a perspective-free drafting board view, used for precise alignments. All Views with the exception of the Camera View are Orthogonal. The term can be used interchangeably with the term orthographic.

output resolution Available in the Export Render dialog, you can set the print resolution of the resulting rendered image expressed in dots per inch.

parallel light A light which cast rays that are perfectly parallel to one another.

patch rendering A technique you can use in Bryce 3D: select a specific area, or patch, of your image for further rendering. Useful to examine areas for detail before doing a final render, or for re-rendering specific areas after making a change, thereby avoiding having to re-render your entire image.

pict mapping A process that interprets a 2-dimensional Pict and expresses it as the surface of a 3-dimensional object, according to a specified algorithm.

pitch Camera rotation around its X axis; kind of a tilt forward or back.

plop-render Just a cute name for our way of representing a marquee selection of your rendered image. Selections appear to "plop" forward, with attendant drop shadows and rendering controls. This feature can be enabled, disabled, or hidden, as you wish.

polygon All 3D objects in Bryce 3D are built from multiple-sided (in Bryce, we use 4 sides)

geometric surfaces, and are therefore inherently polygonal in nature.

primary rays The quantity of virtual rays of light that are initially "shot" into the Bryce scene.

primitive A basic geometric form, such as a cube or sphere, used as a basis for constructing compound 3D objects such as buildings, rocket ships, or snowmen.

primitives Like primary colors, Primitives are Bryce's primary objects. Spheres, cubes, cylinders, pyramids, cones, disks, squares, and toruses are all primitives.

procedural objects Procedural objects are object that require special constructions or "procedures" to create them. Procedures can include operations such as preassignment of materials, randomization of internal parameters or assignment of light properties. For example, terrains.

radial light A light which casts rays equally in all directions.

ray hits The total number of times all rays strike objects in your scene. Note: The total of Ray Hits and Misses is not equal to the total of Primary and Shadow rays because secondary rays are not quantified in the Render Report.

ray misses. The total number of rays that are fired, but strike no objects in your scene. Note: The total of Ray Hits and Misses is not equal to the total of Primary and Shadow rays because secondary rays are not quantified in the Render Report.

raytracing An image synthesis technique by which a virtual beam of light is projected from a virtual camera into a 3D scene in order to evaluate shading and visibility. The virtual beam may be absorbed, reflected, or otherwise

affected to some degree by every object it strikes. For instance, if it hits your sky, then a blue sky color ends up on that portion of your virtual "film", your image. In this way, a final color is determined for each pixel in your image.

reflectivity The degree to which an object bounces light back from its surfaces.

refraction As a light wave passes from air through another medium such as water or thick glass, it seems to bend or turn to a certain degree. This phenomenon is known as refraction, and the degree to which light bends or turns in these situations is controlled by the Refraction channel in the Materials Lab.

relative coordinates Values which express location, orientation, or size relative to the current location, orientation or size.

render The complex process of building a 2-dimensional bitmapped image from all the information contained in your 3-dimensional wireframe scene.

render resolution The size of your rendered image, expressed in pixels, or as a multiple of your Document Resolution. The implication here is that your rendered image can be larger or smaller than your Document Resolution.

replicate While Duplicate will create a copy of your selected object, Replicate will create a copy of the object and the last 3D transformations applied. If you create an object, move it up a bit and rotate it a bit, selecting Replicate will create a copy, move it and rotate it for you; Multi-replicate will do the same with multiple copies in one step.

roll Camera rotation around its Z axis; kind of a left/right tilt. Also known as banking, it creates the illusion that your horizon is tilted.

rotation An object's rotation in 3D space, expressed in degrees; synonymous with orientation.

scale Values that express the space an object occupies; synonymous with Size, though Size implies an absolute space.

scene a) The complete content of your Bryce world; b) The two-dimensional screen projection of your 3D scene; c) The file that Bryce saves, containing all information regarding your landscape.

secondary rays When a primary virtual light ray strikes an object, if that object is reflective or transparent, another secondary ray is fired from that location (either bounced, if reflective, or bent, if transparent/refracted) to continue through the scene. This process is repeated up to six times, to find a home for the ray, and therefore a final color for a pixel in your scene. Secondary rays are not quantified in the Render Report.

shadow rays Once a primary or secondary virtual light ray has found a final resting place, it must determine whether or not to create a shadow behind the object. To do so, another ray is fired from that location, and this is a shadow ray.

size Values that express the space an object occupies; synonymous with Scale, though Scale implies a relative size.

sky dome A secondary environmental ambient light, used to create a color cast in a scene where there is little visible global light.

smoothing Imported objects consist of polyhedral faces, which, when rendered, appear quite chunky. This is not, in most cases, desirable. Use the smoothing command to eliminate this chunkiness. You can set a threshold angle for smoothing as well.

snap to A special form of 3D Transformation changes the selected object's position based on the Snap To. command you select. These commands are located in the Edit palette, in the Alignment Options menu.

solid texture A three-dimensional mathematical description of an object's textural characteristics. Often referred to as procedural texture.

specular The "highlight" of any object with a shiny surface; light that reflects non-uniformly in specific directions depending on the surface roughness. "Specular highlight" refers to the point where specular reflection is most pronounced.

spotlight A light which casts rays in a cone shaped spread; often used top create the classic "Hollywood spotlight" effect.

square spotlight Similar to the SpotLight, but casts rays in a pyramid-shaped spread; think of it as a slide projector.

symmetrical lattice A procedural Bryce Terrain object which has another Terrain mirrored at the base.

terrain An object used in Bryce as the basis for mountains, islands, plateaus, and other landscape objects.

terrain canvas The area in the Terrain Editor onto which you paint and apply effects. Terrain data can be rendered at many levels of detail, from 16x16 to 1024x1024. This resolution does not refer to the wireframe that is used to represent the terrain, but instead to the grayscale data used to determine the internal level of detail used to generate the terrain. Terrains with lower resolutions will appear chunky, and will render very quickly; use these for terrains that are far in the background or where detail is not so important. Terrains with higher resolutions will show increasing levels of detail, and

will take much longer to render; use these for foreground terrains, or in other cases where detail is important.

terrain resolution Terrain geometry can be rendered at several levels of detail. At very low settings, you may see geometric “facets” in your terrains, even with “smooth surfaces” selected. In this case, increase your terrain resolution. Low resolution rendering is often best for items in the far background, where detail is not so important.

texture component a part of an object’s material. Texture Components, which can either be a 2D Picture or 3D Texture.

texture mapping A process of applying detail to a surface without actually affecting the object’s geometry. Values from the texture can determine or affect any surface characteristic, including color, reflectivity, transparency, or bumpiness.

torus A Bryce primitive that looks like a donut.

transparency The measure of an object’s ability to transmit light through its surfaces. Also referred to as transmittivity.

triangulation The process of splitting up geometric faces into triangles for greater flexibility.

unity The state a Bryce object is in when it is first created, or just after the Unity button has been pressed; positioned within a “cube” of fixed size in an invisible 3D grid, with no rotation applied.

view The sum of camera position in 3D space, plus 2D Projection pan and scale values.

wireframe A mesh representation of a 3D object.

wireframe resolution Your onscreen wireframe objects can be displayed at various levels of detail; this display resolution can be set discreetly for static, selected, and moving wireframes. This resolution has no relevance to document, render, or output resolution.

world space A method for representing objects in 3D space. It uses a fixed, or absolute, set of arbitrarily determined Cartesian coordinates.

yaw Camera rotation around its Y axis; kind of turning to look right or left.

MetaCreations License Agreement

By using this software you are agreeing and indicating your acceptance of these terms and conditions. If you do not agree with them you should return the software to the dealer from whom you purchased the product and your money will be refunded. If the dealer from whom you purchased this package fails to refund your money, contact MetaCreations Corp. immediately at the address below. MetaCreations Corp. (hereinafter referred to as Company), a Delaware-based Corporation, provides the computer software (hereinafter referred to as Program) contained on the medium in this package and licenses its use. You assume full responsibility for the selection of the Program to achieve your intended results and for the installation, use and results obtained from the Program.

License

A. In consideration of the payment of a license fee, you are granted a personal, non-transferable and non-exclusive license to use the Program under the terms stated in this Agreement. You own the diskette or other physical media on which the Program is provided under the terms of this Agreement, but all title and ownership of the Program and enclosed related documentation (hereinafter referred to as Documentation), and all other rights not expressly granted to you under this Agreement, remain with the Company.

B. The Program may be used by you only on a single computer. Therefore, you must treat this software just like a book. With the exception of Item D below, "just like a book" means that this software may be used by any number of people and may be freely moved from one computer location to another, so long as there is no possibility of it being used at one location while the same copy is at the same time being used at another location. Just as the same copy of a book cannot be read by two different people in two different places at the same time, neither can the same copy of software be used by two different people in two different places at the same time. Site licenses for multiple single users are available. Contact MetaCreations Corp. for details.

C. You and your employees and agents are required to protect the confidentiality of the Program. You may not distribute or otherwise make the Program or Documentation available to any third party.

D. You may not copy or reproduce the Program or Documentation for any purpose except to make one (1) archival copy of the Program, in machine readable or printed form, for backup purposes only in support of your use of the Program on a single computer. You must reproduce and include the Company copyright notice on the backup copy of the Program.

E. Any portion of the Program merged into or used in conjunction with another program will continue to be the property of the Company and subject to the terms and conditions of this Agreement. You must reproduce and include Company's copyright notice on any portion merged in or used in conjunction with another program.

F. You may not sublease, assign or otherwise transfer the Program or this license to any other person without the prior written consent of Company.

G. You acknowledge that you are receiving a LIMITED LICENSE TO USE the Program and Documentation and that the Company retains title to the Program and Documentation. You acknowledge that Company has a valuable proprietary interest in the Program and Documentation. You may not use, copy, modify or transfer the Program or Documentation or any copy, modification or merged portion in whole or in part except as expressly provided for in this Agreement. If you transfer possession of any copy, modification or merged portion of the Program or Documentation to another party, your license is automatically terminated.

H. If you have purchased a NETWORK version of the software, this License Agreement applies to the installation of the software onto a single file server. It may not be copied onto multiple systems. Each node connected to the file server must also have its own node copy of the software that becomes a license for that specific user.

Term

This license granted to you is effective until terminated. You may terminate it at any time by returning the Program and Documentation to Company together with all copies, modifications and merged portions in any form. The license will also terminate upon conditions set forth elsewhere in this Agreement, or if you fail to comply with any term or condition of this Agreement. You agree upon such termination to return the Program and Documentation to Company together with all copies, modifications and merged portion in any form. Upon termination, Company can also enforce any rights provided by law. The provision of this Agreement which protects the proprietary rights of Company will continue in force after termination. Termination of this license, either voluntary or involuntary, does not entitle you to a refund of your purchase cost except as provided elsewhere in this License Agreement.

Limited Warranty

Company warrants, as the sole warranty, that the medium on which the Program is furnished will be free from defects in materials and workmanship under normal use and conditions for a period of ninety (90) days from the date of delivery to you as evidenced by a copy of your receipt. No distributor, dealer or any other entity or person is authorized to expand or alter either this warranty or this Agreement. Any such representations will not bind the Company. Company does not warrant that the functions contained in the Program will meet your requirements or that the operation of the Program will be uninterrupted or error-free. Except as stated above in this section, the Program and Documentation are provided as-is without warranty of any kind either expressed or implied, including but not limited to the implied warranties of

merchantability and fitness for a particular purpose. You assume entire risk as it applies to the quality and performance of the Program and Documentation. Should the Program prove defective you (and not Company, authorized Company Distributor or dealer) assume the entire cost of all necessary servicing repair or correction. This warranty gives you specific legal rights and you may also have other rights which vary from state to state. Some states do not allow the exclusion of implied warranties, so the above exclusion may not apply to you.

Limitation of Remedies

Company's entire liability and remedy will be:

A. The replacement of any medium not meeting Company's 'Limited Warranty' explained above and which is returned to Company or an authorized Company distributor or dealer with a copy of your receipt; or

B. If Company is unable to deliver a replacement medium which conforms to the warranty provided under this Agreement, you may terminate this Agreement by returning the Program and Documentation to Company, authorized Company Distributor, or dealer from whom you obtained the Program and your license fee will be refunded.

Product Returns

If you must ship the Program and Documentation to an authorized Company Distributor, dealer or to Company, you must prepay shipping and either insure the Program and Documentation or assume all risk of loss or damage in transit. To replace a defective medium during the ninety (90) day warranty period, if you are returning the medium to Company, please send us your name and address, the defective medium and a copy of your receipt at the address provided below. In no event will Company be liable to you for any damages, direct, indirect, incidental or consequential, including damages for any lost profits, lost savings or other incidental or consequential damages arising out of the use or inability to use such Program and Documentation, even if Company has been advised of the possibility of such damages or for any claim by any other party. Some states do not allow the limitation or exclusion of liability for incidental or consequential damages so the above limitation or exclusion may not apply to you. In no event will Company liability for damages to you or any other person ever exceed the amount of the license fee paid by you to use the Program regardless of the form of the claim.

US Government Restricted Rights

The Program and Documentation are provided with restricted rights. Use, duplication or disclosure by the US Government is subject to restrictions as set forth in subdivision (b) (3) (ii) of the Rights in Technical Data and Computer Software Clause at (252) 227-7013. Contractor/Manufacturer is MetaCreations Corp., 6303 Carpinteria Avenue, Carpinteria, CA 93013.

General

This Agreement is governed by the laws of the state of California (except federal law governs copyrights and register trademark(s)). If any provision of this Agreement is deemed invalid by any court having jurisdiction, that particular provision will be deemed deleted and will not affect the validity of any other provision of this Agreement. Should you have any questions concerning this Agreement, you may contact MetaCreations Corp. at this address:

MetaCreations Corp.
6303 Carpinteria Avenue
Carpinteria, CA 93013
(805) 566-6200 phone
(805) 566-6385 fax

©1999 MetaCreations Corp. All rights reserved. MetaCreations and Bryce are registered trademarks and the MetaCreations logo is a trademark of MetaCreations Corporation. All other product names mentioned in the Program, manual or other documentation are used for identification purposes only and may be trademarks or registered trademarks of their respective companies. Registered and unregistered trademarks used herein are the exclusive property of their respective owners. MetaCreations Corp. makes no claim to any such marks, nor willingly or knowingly misused or misapplied such marks.